

**PANDUIT**<sup>®</sup>

infrastructure for a connected world



## FiberRunner<sup>®</sup> Cable Routing System

Versatile, Scalable Cable Protection in  
Data Centers and Central Offices

# The Need for Cable Routing

## What is a Cable Routing System?

A cable routing system is a collection of channels, fittings, and mounting brackets that can be assembled to create a structure that routes and protects fiber optic and high-performance copper data cabling. This type of system is an integral component of the overall cable management strategy to prevent physical damage that can result in a disruption of critical network connections.

## Can you afford improper cable routing?

According to Gartner, the average cost of IT downtime is \$5,600 per minute. Because there are so many differences in how businesses operate, downtime, at the low end, can be as much as \$140,000 per hour, \$300,000 per hour on average, and as much as \$540,000 per hour at the higher end.◇

Contributing to network downtime is improperly routed or unprotected fiber optic cable, which is susceptible to various types of damage. Crushing, pinching, or micro bending can result in impeded signal transmission and cable breakage. Bend radius violations, or macro bending, in fiber optic and copper cables can increase attenuation affecting overall system performance and cause fatigue leading to long-term signal failure.

A properly designed and installed cable routing system carries cabling along a logical route to minimize bends and optimize cable lengths while providing easy access to make moves, adds, or changes. A well-engineered and installed cable routing system costs a fraction of the potential downtime losses and day-to-day operating costs over the life of the network, thereby reducing the total cost of ownership.

## The Value of the Panduit Solution

The Panduit® FiberRunner® Cable Routing System ensures maximum network reliability and reduced cost of ownership. Robust, highly engineered components with integral bend radius control surfaces can be configured to meet virtually any network application to provide optimum cable protection and assure network performance. Fast and easy to deploy, this scalable cable routing solution reduces installation cost and speeds implementation of new services.

## System Sizes

The FiberRunner® Cable Routing System is offered in five channel sizes providing a range of cable capacity.



24x4 FiberRunner®  
Channel Profile



12x4 FiberRunner®  
Channel Profile



6x4 FiberRunner®  
Channel Profile

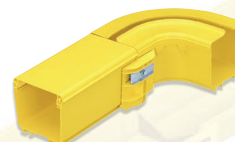

4x4 FiberRunner®  
Channel Profile



2x2 FiberRunner®  
Channel Profile

Gartner ◇ Read about: [“The Cost of Downtime”](#)

## FiberRunner® Cable Routing System Benefits

**Ensure network reliability** with a complete solution that protects cables from physical damage while maintaining signal integrity and delivering reliable network performance.

- Strong, rigid channel and cover profiles protect cables from impact damage
- Directional fittings provide integral bend radius control and smooth surfaces, protecting cables from bends and snags

**Reduce installation costs** with innovative snap-together couplers, mounting brackets, and accessories that require minimum use of tools and small fasteners to assemble. These components are part of a comprehensive system that provides lower installed cost.

- QuikLock™ Couplers allow components to be assembled in less than five seconds without the use of tools
- Covers snap on to channels and fittings, eliminating the need for tools or small fasteners
- QuikLock™ Mounting Brackets allow channel to be attached to infrastructure without drilling or using small, loose fasteners

**Enable future growth** or modification with a complete offering of sizes, fittings, and mounting options that make this system one of the most versatile cable routing solutions available.

- Wide range of directional fittings allows the system to meet virtually any network configuration
- Broad assortment of QuikLock™ Mounting Brackets allow the system to be mounted to any type of infrastructure

**Lower cost of ownership** through a combination of unique features and standards compliance.

- Snap-on, hinged channel covers, and split fitting covers allow easy access to cables without fully removing covers, thereby reducing time required to make moves, adds, and changes
- Compliance with stringent industry standards including UL 2024, UL 94V-0 and NEBS GR-63 (ensures that system features and functions will withstand regular use and perform over the lifetime of the installation)
- Solid, maintenance-free, non-metallic channel and fitting construction will last the life of the system

**The FiberRunner® Cable Routing System** is offered in five channel sizes (2", 4", 6", 12" and 24") providing a range of cable capacities.



Innovative Snap-On hinged covers attach without use of tools or small fasteners.



QuikLock™ Coupler provides fast connection between components without need for tools or small fasteners.

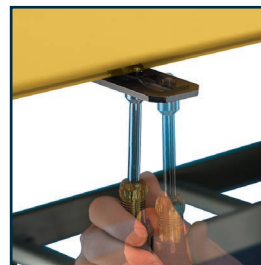

QuikLock™ Mounting Brackets speed implementation.

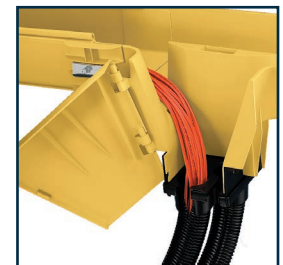

Spill-out fittings provide bend radius control to protect cables.



Wide range of directional fittings provides flexibility.

## Data Center Cable Pathway Roadmap

Below is a typical data center FiberRunner™ Cable Routing System application. The pathway is configured to route and protect cabling between the Main Distribution Area (MDA) and the Equipment Distribution Areas (EDA)<sup>2</sup>. Key features include the innovative QuikLock™ Coupler that is used to securely join system components, a wide range of spill-out options to transition cable into the cabinets, and a complete offering of directional fittings and channel sizes.

The FiberRunner™ Cable Routing System integrates with a complete offering of Panduit Racks and Cable Management Systems to help manage higher cable densities as well as StructuredGround™ Systems designed to protect all elements of the data center.

### Transitions to Other Channel Sizes

(See detail on page 6.)

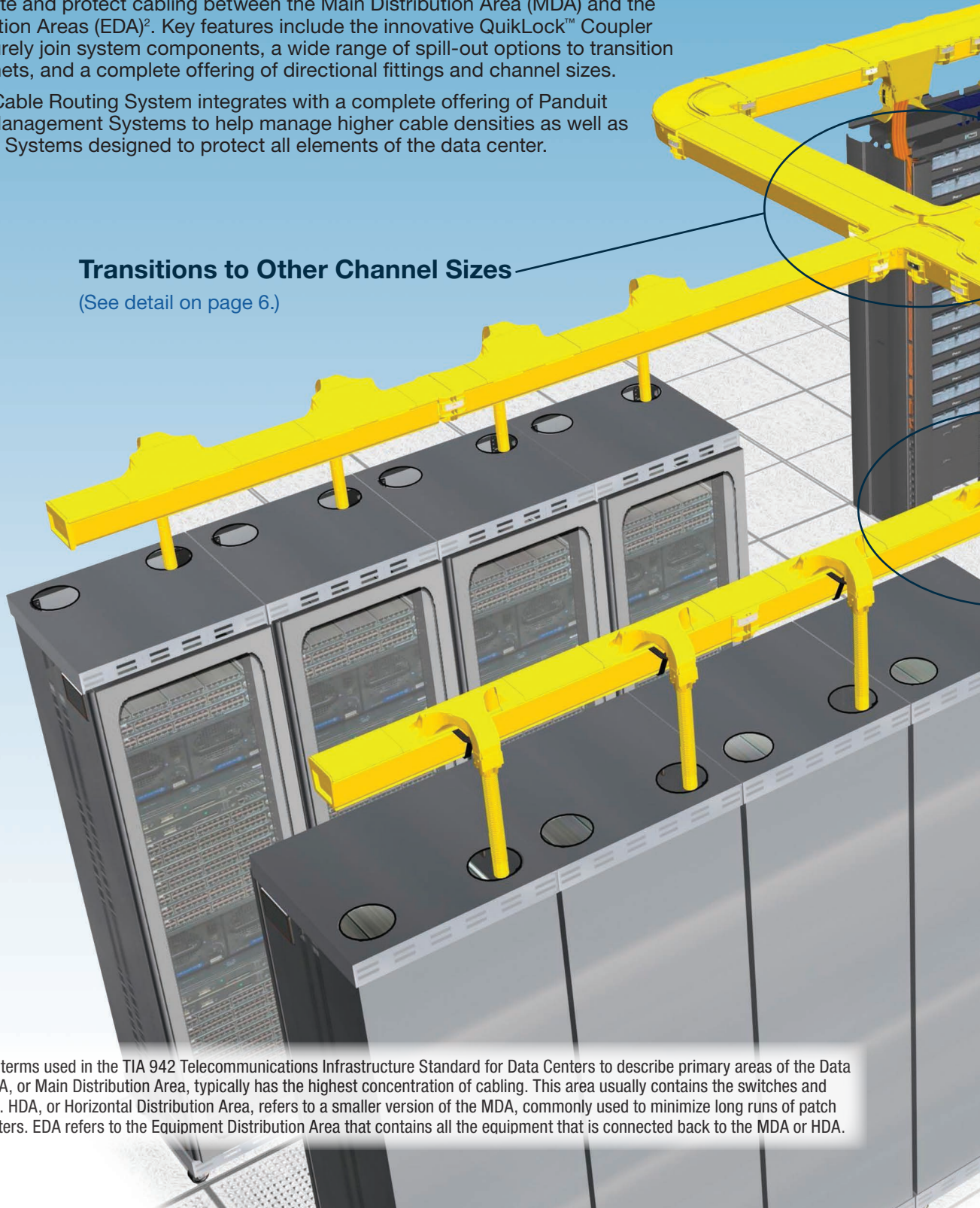

<sup>2</sup>MDA, EDA and HDA are terms used in the TIA 942 Telecommunications Infrastructure Standard for Data Centers to describe primary areas of the Data Center topology. The MDA, or Main Distribution Area, typically has the highest concentration of cabling. This area usually contains the switches and associated patching field. HDA, or Horizontal Distribution Area, refers to a smaller version of the MDA, commonly used to minimize long runs of patch cables in larger data centers. EDA refers to the Equipment Distribution Area that contains all the equipment that is connected back to the MDA or HDA.

### Routing Cables In and Out of the MDA

(See detail on page 6.)

### QuikLock™ Coupler Feature



QuikLock™ Coupler speeds assembly of system components without the need for tools or small fasteners.

### Protecting Cable Transitioning to EDA Cabinets

(See detail on page 6.)

### Typical Application Configuration:

#### Plan View of Distribution and Feeder Design

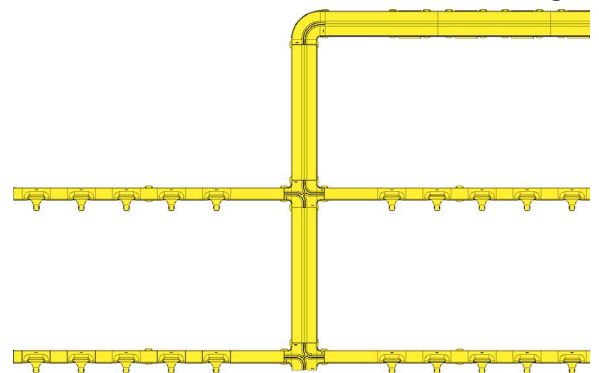

The distribution and feeder configuration is the basic, economic layout used to route cables out of the MDA.

A higher capacity distribution run is used to supply the feeders that route cables out to the cabinets in the EDA.

The Feeders in turn are positioned over the cabinet line ups to create a pathway that will provide efficient transitions to the vertical cable management areas of the cabinets and not interfere with cold aisle cooling air flow.

## Data Center Roadmap Details

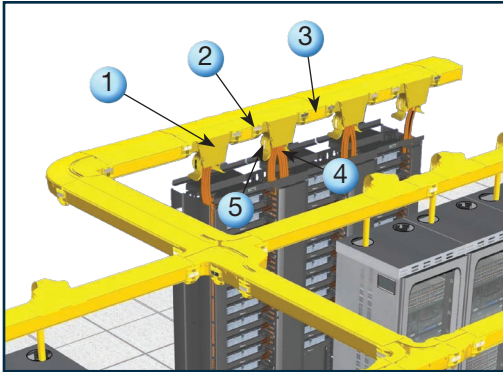

### Routing Cable Out of the MDA

The FiberRunner® System includes vertical tee fittings for routing cables out of the MDA racks. These fittings can be sized for the anticipated cable capacity and positioned directly above the vertical cable managers to create as direct a pathway as possible.

#### Components used in this detail:

1. FRVT12X4LYL Vertical Tee
2. FRBC12X4LYL QuikLock™ Coupler
3. FR12X4YL6 Channel
4. FRTR6X4LYL Three-Sided Bend Radius Control Trumpet
5. FRBC6X4LYL QuikLock™ Coupler

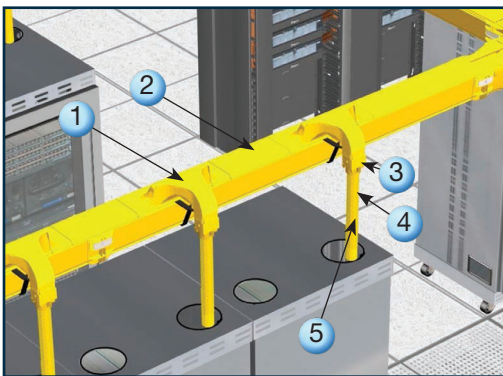

### Transitioning Cables Into the EDA Cabinets

The FiberRunner® System offers a wide variety of spill-out options to provide safe, accessible transitions to the cabinets in the EDA.

Spill-over fittings, which can be attached to any straight section of channel, can be used at the initial installation or retrofit into existing configurations as the network changes or grows.

#### Components used in this detail:

1. FRSPJ2X2LYL Spill-Over Junction
2. FR6X4YL6 Channel
3. FBC2X2LYL QuikLock™ Coupler
4. FIDT2X2LYL Transition to 1.5" ID Slit Corrugated Loom Tubing
5. CLT150F-X4F 1.5" ID Slit Corrugated Loom Tubing

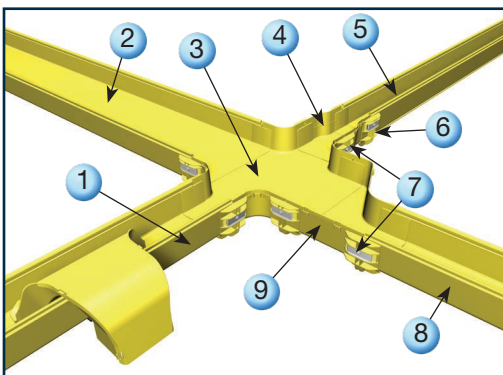

### Transitions to Other Channel Sizes

Reducer fittings are available to provide a method of transitioning between different FiberRunner® System sizes. In addition, 12x4 tee fittings and 4-way crosses with integral 6x4 exits can be used to create feeder runs.

#### Components used in this detail:

1. FRBC12X4LYL QuikLock™ Coupler
2. FR12X4YL6 Channel
3. FRFWC12X4W6LYL 4-Way Cross with 6x4 Exits
4. FRRF6FR4LYL 6x4 to 4x4 Reducer Fitting
5. FR4X4YL6 Channel (6 ft. channel)
6. FRBC4X4LYL QuikLock™ Coupler
7. FRBC6X4LYL QuikLock™ Coupler
8. FR6X4YL6 Channel (6 ft. channel)
9. FRRF126RLYL 12x4 to 6x4 Transition Right Reducer Fitting

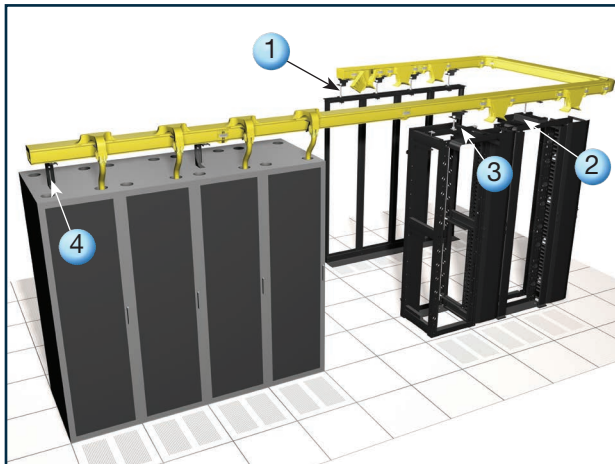

## Supporting the System Directly on Racks and Cabinets

When an overhead infrastructure is not available, there are several options that allow the FiberRunner® System to be mounted to the tops of Panduit® NetFrame® Racks, 4 Post Racks, EIA/TIA racks, and Panduit® Cabinets.

### Components used in this detail:

1. FEIAB58 EIA/TIA Threaded Rod Bracket
2. FRRMBNF58 NetFrame® Rack Bracket
3. FR4PRB58 4 Post Rack Bracket
4. FR6ACAB Adjustable Cabinet Bracket

(See pages 12 – 13 for full range of mounting brackets.)

## Telecommunication Room Roadmap

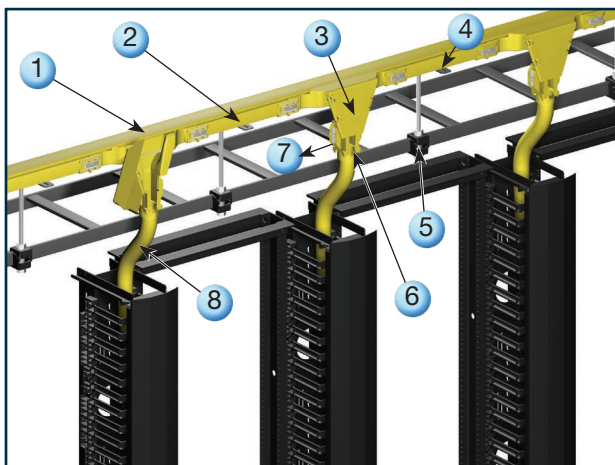

Panduit offers a complete line of structured cabling products for telecommunication room applications including rack systems, vertical and horizontal cable management systems, grounding and power connectors, patch panels, DPoE™ Power Patch Panels, fiber optic cable, and fiber optic connectivity products.

## Telecommunications Rooms

As an alternative to inner duct or exposed cabling on ladder rack or wire basket tray, the 2x2 FiberRunner® Hinged Duct can be used to route and protect small amounts of fiber cable along racks. Vertical Tees with integral hinged doors provide access and protection. Snap together transitions to slit corrugated loom tubing and QuikLock™ Couplers reduce installation time.

### Components used in this detail:

1. HC2YL6 FiberRunner® Hinged Cover
2. HS2X2YL6 FiberRunner® Hinged Channel
3. FVTHD2X2LYL Vertical Tee
4. FTRBN12 New Threaded Rod Bracket
5. F2PCLB12 Two-Piece Clamping Ladder Rack Bracket
6. FIDT2X2LYL Transition to 1.5" ID Slit Corrugated Loom Tubing
7. FBC2X2LYL QuikLock™ Coupler
8. CLT150F-X4F 1.5" Slit Corrugated Loom Tubing

## Service Provider Central Office Cable Pathway Roadmap

In this application, the FiberRunner® Cable Routing System is used to segregate fiber optic jumper cables from all of the other cables routed in the central office. The system offers a wide variety of transitions from horizontal runs to the vertical cable managers on Network Element Bays, supporting accessibility and protection, while reducing the time required for moves, adds, and changes.

### Transitioning to the Network Element Bays

(See detail on page 10 – 11.)

### Protecting the Pathway with Covers

(See detail on page 14.)

<sup>3</sup>FDF (Fiber Distribution Frame) refers to the rack or bay lineup that contains the fiber optic cross-connect. Typically the highest density of fibers are routed from this location. Network Element Bays refers to the bays that contain the network equipment that the fiber optic jumper cables are routed to.



### Mounting to Central Office Infrastructure

(See detail on pages 12 – 13.)

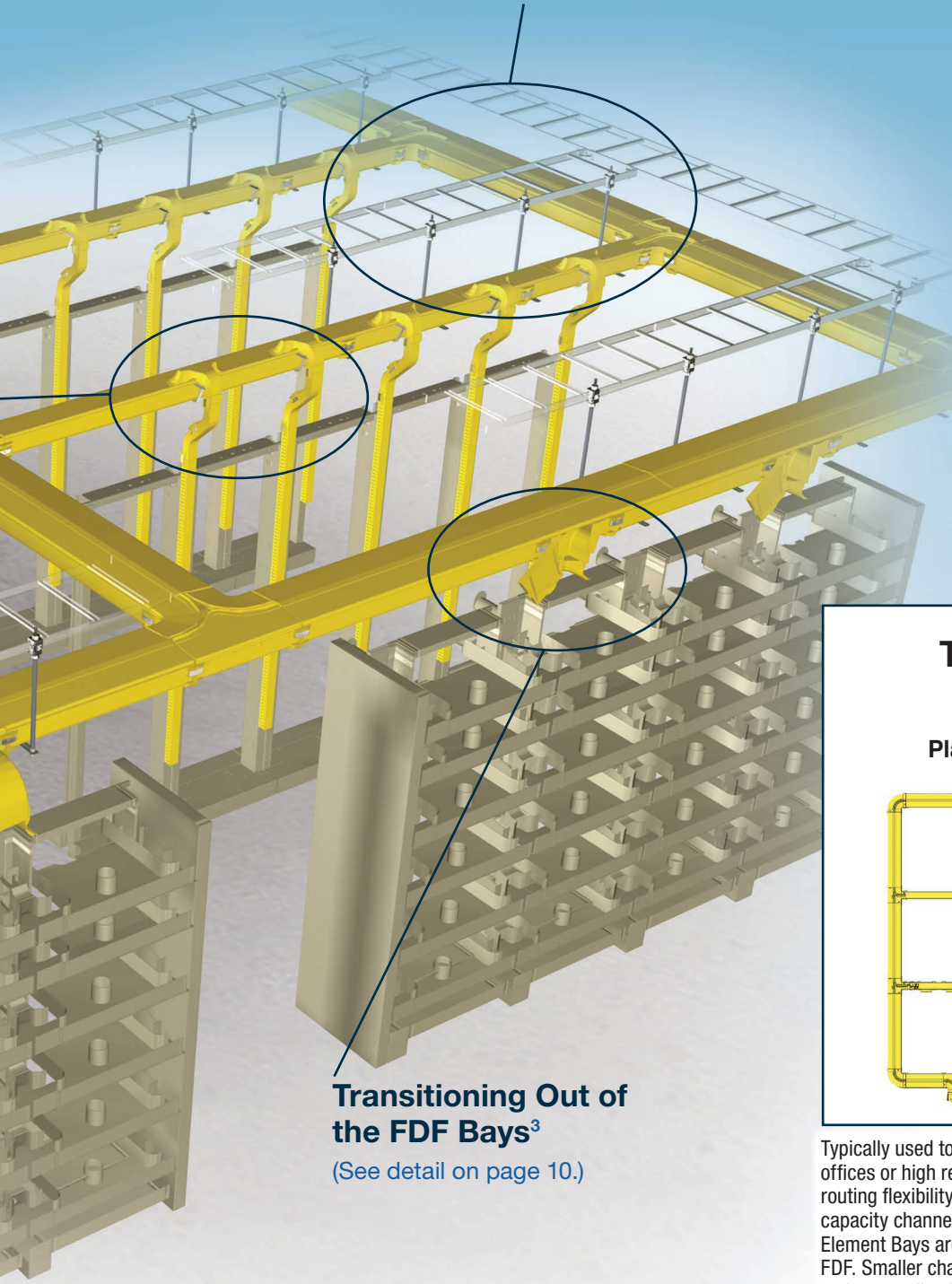

### Transitioning Out of the FDF Bays<sup>3</sup>

(See detail on page 10.)

### Snap-On Hinged Cover Feature



Snap-on cover design speeds installation by eliminating the need to use tools or small fasteners.

### Typical Application Configuration:

Plan View of Perimeter Design

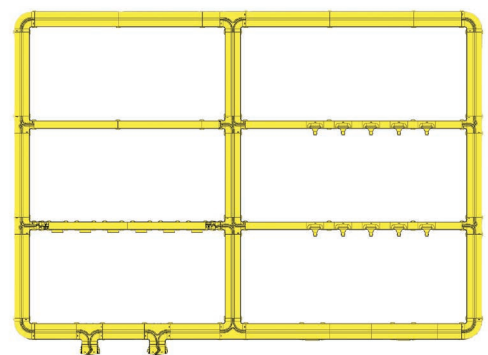

Typically used to create a physically redundant pathway in central offices or high reliability data centers, this design also provides more routing flexibility and reduces cable congestion. A larger, higher capacity channel forms a perimeter around the FDF and Network Element Bays areas to provide a diverse route for cables leaving the FDF. Smaller channels are used to create pathways between the main runs allowing access to the individual equipment bays.

## Service Provider Roadmap Details

(See Roadmap on pages 8 and 9.)

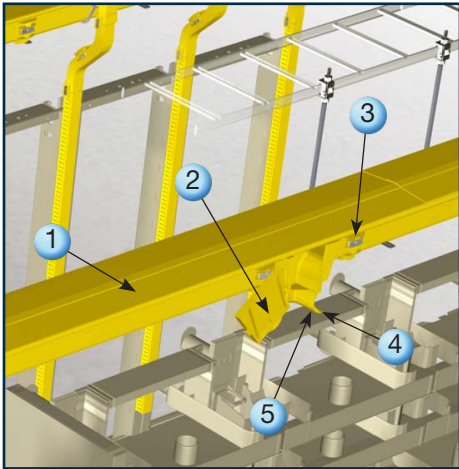

### Transitioning Cable Out of the FDF Bays

For fiber optic jumper cables routed in and out of the fiber distribution frame, high capacity vertical tee fittings are positioned directly above the vertical fiber slack managers providing as direct a pathway as possible. Vertical tee fittings are typically positioned with doors facing the maintenance aisle to provide access to the cables.

**Components used in this detail include:**

1. FR12X4YL2 Channel and FRHC12YL6 Cover
2. FRVT12X4LYL Vertical Tee
3. FRBC12X4LYL QuikLock™ Coupler
4. FRBC6X4LYL QuikLock™ Coupler
5. FRTR6X4LYL Three-Sided Bend Radius Control Trumpet

### Transitioning Cables Into the Network Element Bays

In service provider environments the preference is to completely enclose the fiber optic jumper cables transitioning from horizontal runs down to the equipment in the Network Element Bays. There are several methods that can be used depending upon the position of the horizontal run relative to the Network Element Bays.

**Described below is a component configuration commonly used:**

1. FRVT6X4LYL or FRVT4X4LYL QuikLock™ Vertical Tee
2. FRLPR42LBL Low Profile Reducer
3. FOV452X2LYL Outside Vertical 45° Angle Fitting
4. FIV452X2LYL Inside Vertical 45° Angle Fitting
5. HC2YL6 FiberRunner® Hinged Cover
6. FZBA1.5X4 Adjustable “Z” Bracket (not visible)
7. H2X2YL6 FiberRunner® Hinged Slotted Channel
8. FBC2X2LYL QuikLock™ Coupler

Another option is to use flexible corrugated loom tubing from the vertical tee fitting to the 2x2 slotted hinged duct. This approach eliminates the time required to position and secure multiple individual fittings to create a protected pathway.

**Components used in this detail include:**

1. FRVT6X4LYL or FRVT4X4LYL QuikLock™ Vertical Tee
2. FRLPR42LBL Low Profile Reducer
3. FIDT2X2LYL Transition to 1.5" ID Slit Corrugated Loom Tubing
4. HC2YL6 FiberRunner® Hinged Cover
5. FZBA1.5X4 Adjustable “Z” Bracket
6. H2X2YL6 FiberRunner® Hinged Slotted Channel
7. FBC2X2LYL QuikLock™ Coupler
8. CLT150F -X4F 1.5" ID Slit Corrugated Loom Tubing

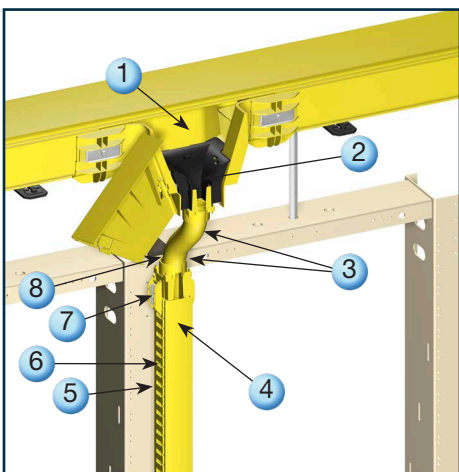
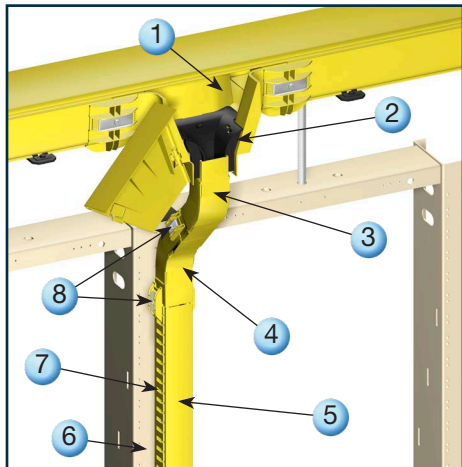

## Transitioning Cables into the Network Element Bays – continued

Spill-over fittings can also be used to create exits over the Network Element Bays. These fittings can be used during initial installation or as a retrofit when a line-up is extended or new equipment is added to the network. In the central office the preference is to completely enclose the fiber optic jumper cables transitioning from horizontal runs down into the equipment in the Network Element Bays.

### Components used in this detail include:

1. FRSPJ2X2LYL Spill-Over
2. FOV452X2LYL Outside Vertical 45° Angle Fitting
3. FIV452X2LYL Inside Vertical 45° Angle Fitting
4. HC2YL2 FiberRunner® Hinged Cover
5. FZBA1.5X4 Adjustable “Z” Bracket (not visible)
6. H2X2YL6 FiberRunner® Hinged Slotted Channel
7. FBC2X2LYL QuikLock™ Coupler

Another option is to use flexible corrugated loom tubing from the spill-over fitting to the 2x2 slotted hinged duct. This approach eliminates the time required to position and secure multiple individual fittings to create a protected pathway.

### Components used in this detail include:

1. FRSPJ2X2LYL Spill-Over
2. FBC2X2LYL QuikLock™ Coupler
3. FIDT2X2LYL Transition to 1.5" ID Slit Corrugated Loom Tubing
4. HC2YL6 FiberRunner® Hinged Cover
5. FZBA1.5X4 Adjustable “Z” Bracket (not visible)
6. H2X2YL6 FiberRunner® Hinged Slotted Channel
7. CLT150F-X4F 1.5" Slit Corrugated Loom Tubing

## Transitioning Cables into High Capacity Network Element Bays

To provide a secure, accessible pathway to high density Network Element Bays, the FRHD4KT 4x4 slotted hinged duct kit can be used. The innovative, hinged cover opens easily from either side without having to be removed from the duct, allowing access to cables, reducing the time needed to make changes.

### Components used in this detail include:

1. FRVT12X4LYL Vertical Tee
2. FRLPR64BL 6x4 to 4x4 Low Profile Reducer
3. FRHD4KTYL 4x4 Hinged Duct Vertical Cable Management Kit

Cable Capacity Comparison	2x2 Slotted Hinged Duct	4x4 Slotted Hinged Duct
2mm Fiber Optic Cable	349	1499
1.6mm Fiber Optic Cable	546	2343

### The FRHD4KT Kit contains:

- 6' length, 4x4 Hinged Slotted Channel
- 6' length, 4" Snap-On Hinged Cover
- Adapter to fit exit of 4x4 or 6x4 QuikLock™ Vertical Tee or 6x4 to 4x4 Low Profile Reducer Fitting
- Three Adjustable “Z” Brackets, End Cap, and Wire Retainers

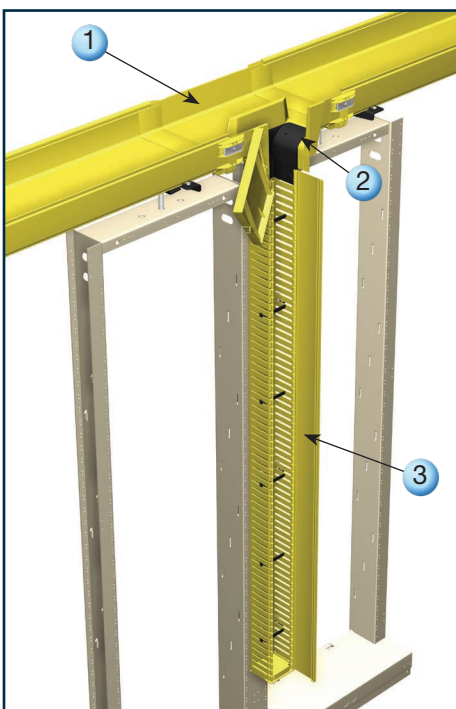
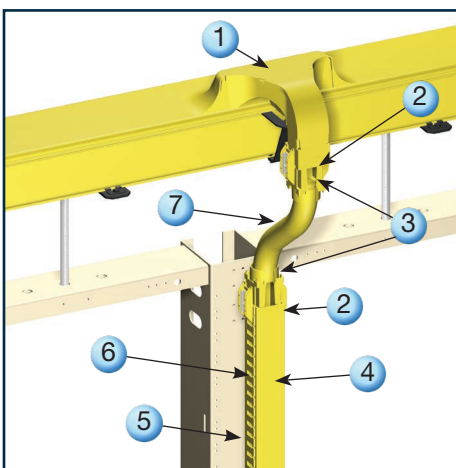
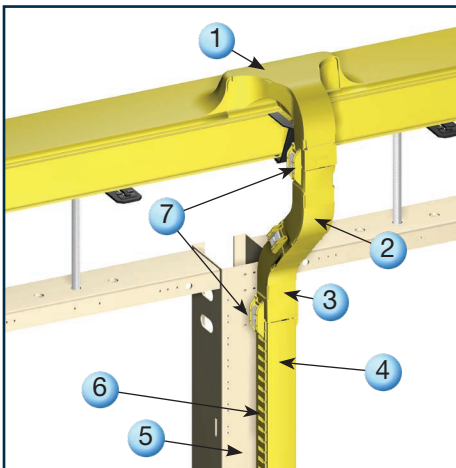

# System Mounting Components

The FiberRunner® System provides a wide range of mounting brackets that secure the system to virtually any data center or service provider infrastructure. QuikLock™ Mounting features reduce assembly time and speed implementation.

**Attaching the System to Common Infrastructures Including Auxiliary Framing Bar, Ladder Rack (Cable Runway), Threaded Rod, Under-Floor Pedestals, and Strut.**

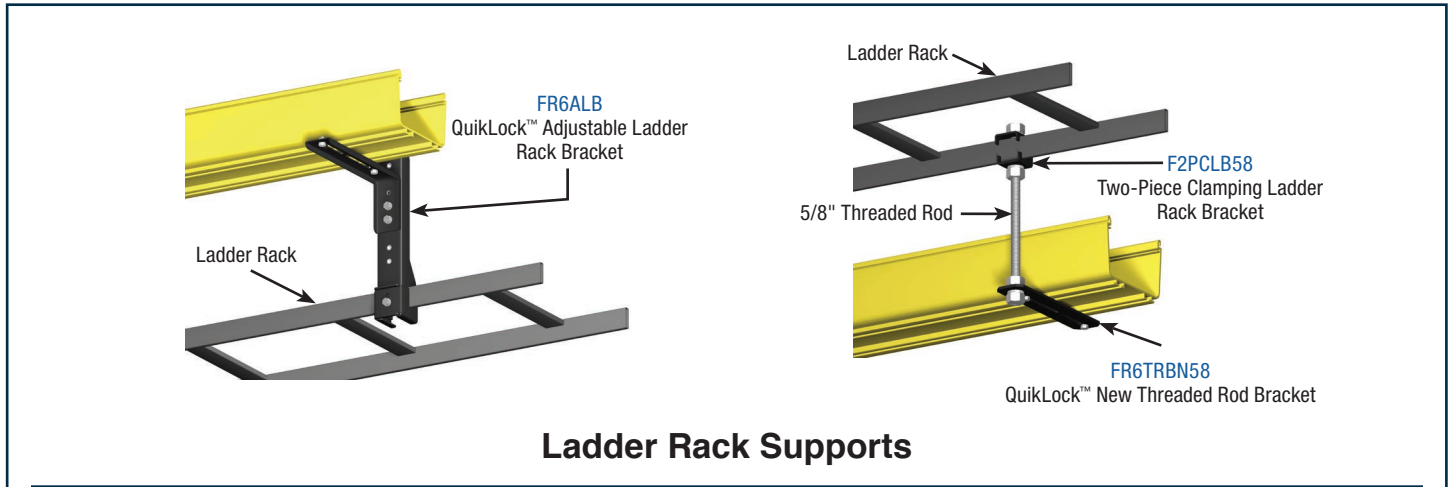

## Ladder Rack Supports

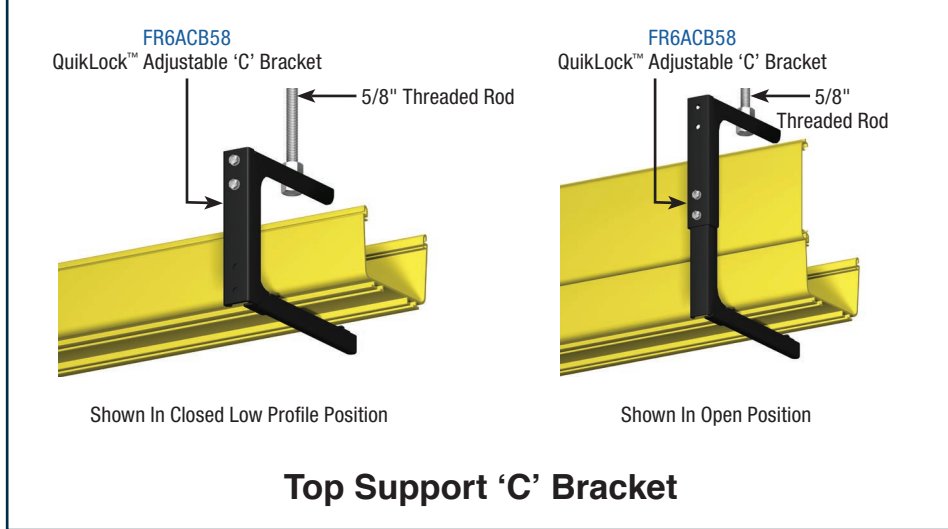

## Top Support 'C' Bracket

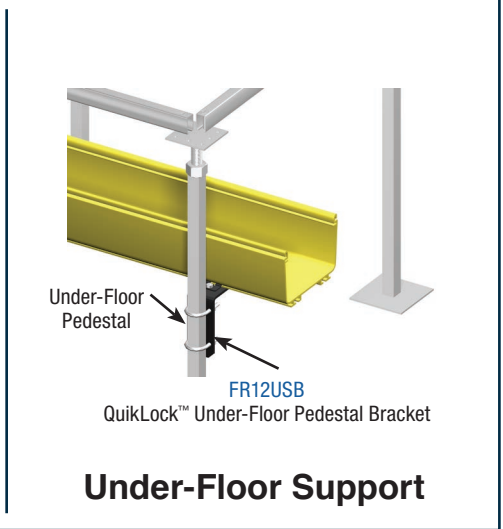

## Under-Floor Support

## Attaching the System Directly to Racks and Cabinets

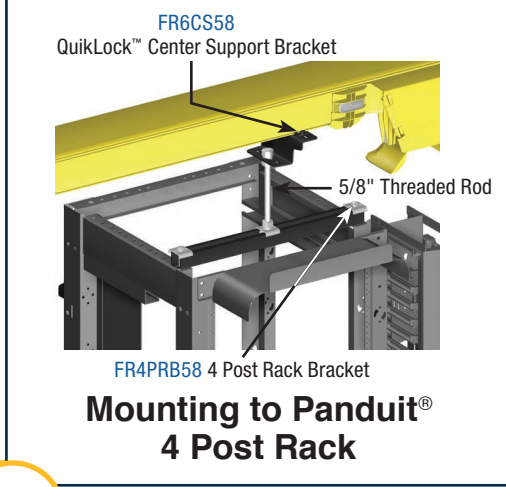

### Mounting to Panduit® 4 Post Rack

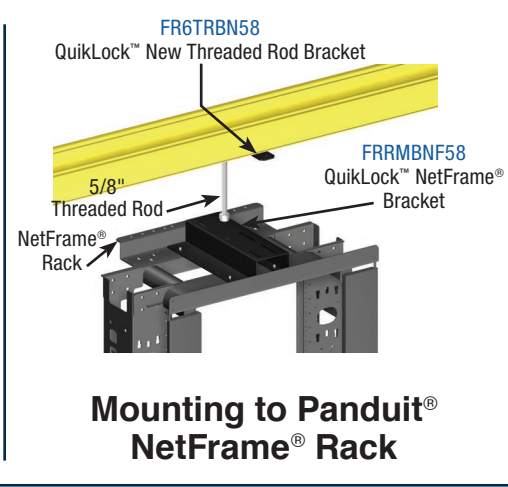

### Mounting to Panduit® NetFrame® Rack

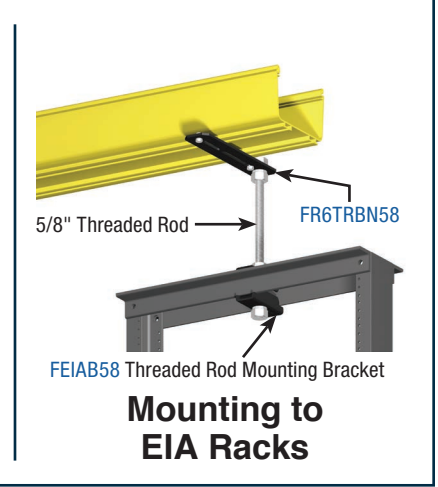

### Mounting to EIA Racks

## QuikLock™ Mounting Feature

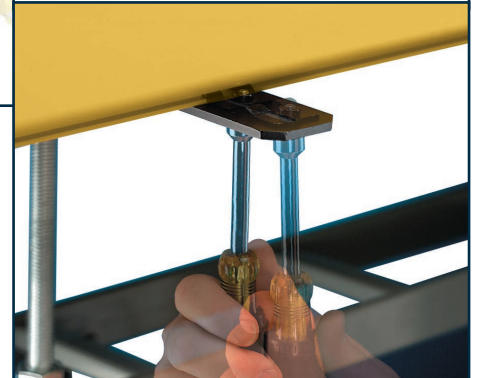

Innovative QuikLock™ Mounting Slide Clamps allow fast assembly with a Standard 7/16" nut driver.

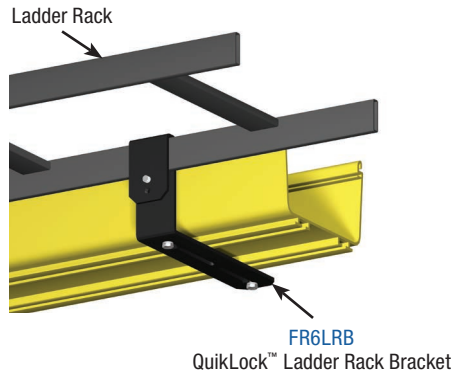
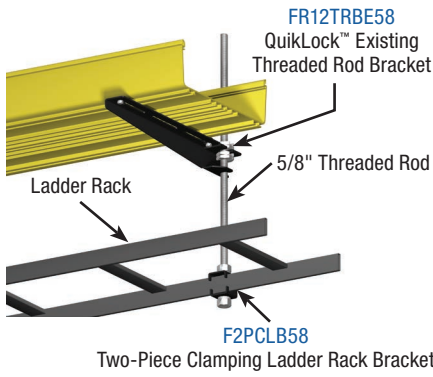

## Ladder Rack Supports

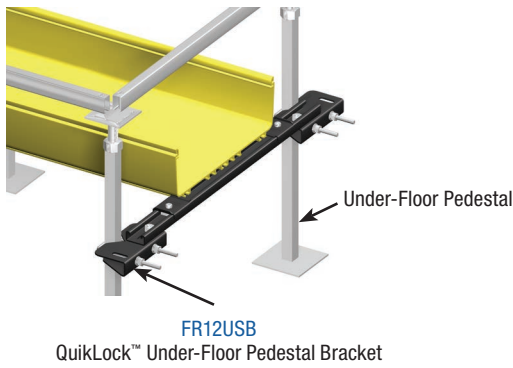

## Under-Floor Support

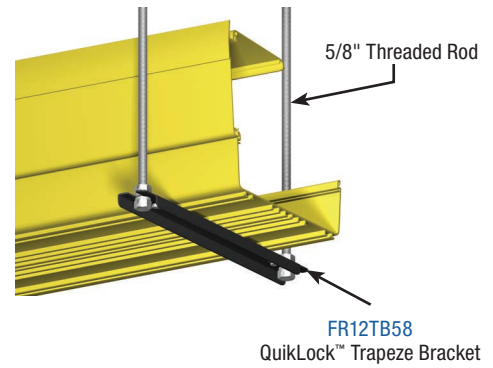

## Trapeze Support

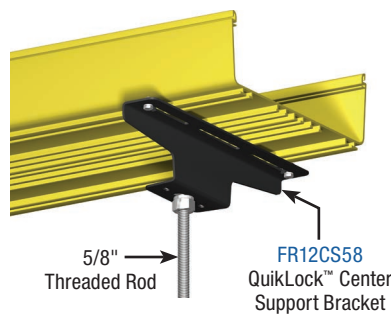
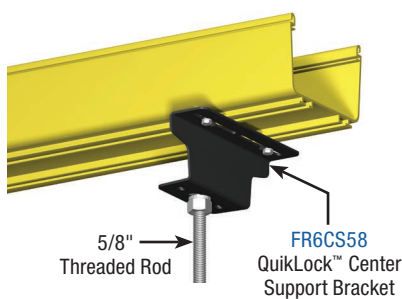

## Center Supports

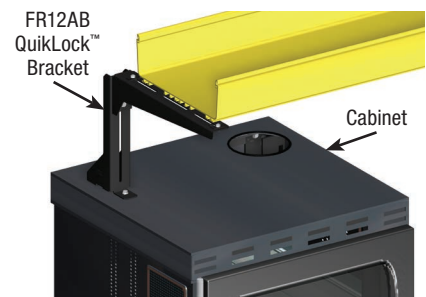

## Mounting to Cabinet Tops

## System Cover Components

The FiberRunner® System provides a comprehensive offering of snap-on covers for channels and fittings. Covers provide protection, enhancing network reliability while enabling ease of access to cables and lowering the cost of ownership.

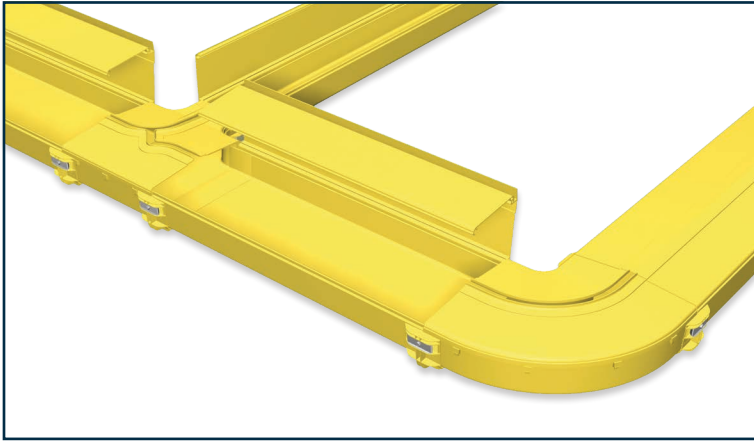

### Protecting the Pathway with Covers

A complete assortment of unique, snap-on hinged channel covers and snap-on split fitting covers are available to provide the highest degree of cable protection while still allowing easy access.

#### Optional Snap-on Hinged Covers:

- Available to support all five channel sizes
- A low-profile split cover solution is available for the 4x4 and 6x4 channel options
- The 12x4 snap-on hinged cover incorporates a unique secondary hinge that minimizes the space required to access the channel in height restricted applications
- The 2x2 snap-on hinged cover can be opened from either side maximizing access to the channel

Optional snap-on split fitting covers can be ordered separately for most fittings, with the exception of the inside vertical directional fittings, which are supplied with covers directional fittings.



Snap-On Hinged Solid Cover



Snap-On Split Hinged Cover



Snap-On Split Fitting Covers

## Color Options

The system is available in two standard colors to meet the need for data center aesthetics and to differentiate between different types of cables routed within a data center or service provider central office.



**Yellow** – Typical color used to denote a singlemode fiber optic cable route.



**Black** – Used in data centers in which aesthetics are more important.

## Design Tools

VISIO\* and AutoCAD\*\* design tools are available which allow accurate system drawings to be created, speeding overall system design, specification, and implementation. Both tools offer drag and drop functionality and an automated BOM generator.

The data center VISIO layout tool can be found at: [www.panduit.com/support/tools/visio](http://www.panduit.com/support/tools/visio) and supports 2D designs.

The AutoCAD® design tool can be found at: [www.panduit.com/support/tools/autocad](http://www.panduit.com/support/tools/autocad) and supports 2D and 3D designs.

## Application Standards

<p><b>NEBS GR-63 CORE, Level 3 Compliance as tested by NTS</b></p> <p>Network Equipment Building Systems (NEBS) was developed by Bellcore, now known as Telcordia Technologies, and is currently maintained by Telcordia Technologies. NEBS was developed to standardize requirements for Central Office Equipment and to develop criteria for personal safety, protection of property, and operational continuity.</p>	<p><b>NEBS Level 3 Criteria is the minimum of environmental compatibility needed to provide maximum assurance of equipment operability within the network facility environment.</b></p> <p>The Level 3 Criteria is the highest assurance of product operability. Products that meet NEBS Level 3 Criteria are suited for equipment applications, which demand minimal service interruptions over the life span of the equipment. The Panduit® FiberRunner® Cable Routing System has successfully passed a range of tests including:</p> <ul style="list-style-type: none"> <li>• Extreme Temperature and Humidity</li> <li>• Operating Temperature and Humidity</li> <li>• Zone 4 Earthquake and Office Vibration</li> <li>• Needle Flame Analysis</li> </ul>
<p><b>UL Underwriters Laboratories, Inc.</b></p> <p>Underwriters Laboratories, Inc. is an independent, not-for-profit safety testing and certification organization based in the United States.</p>	<p><b>UL 2024 Optical Fiber Cable Routing Assemblies</b></p> <p>Covers, fittings and components construction, flammability rating and marking. The FiberRunner® Cable Routing System has passed test requirements for Riser Rated applications.</p> <p><b>UL94 V-0 Flammability Rating</b></p> <p>Underwriters Laboratories, Inc. Standards applicable to specified Panduit® FiberRunner® Cable Routing System components.</p>
<p><b>TIA Telecommunications Industry Association</b></p> <p>The Telecommunications Industry Association is a leading U.S. non-profit trade association serving the communications and information technology industry.</p> <p>TIA represents providers of communications and information technology products and services for the global marketplace through its core competencies in standard development.</p>	<p><b>ANSI/TIA-942 Draft 5.0a – Telecommunications Infrastructure Standard for Data Centers ANSI/TIA-569-B Commercial Building Standard for Telecommunications Pathways and Spaces</b></p> <p>Referenced as a method of separating and routing data cable in overhead cable routing applications. The Panduit® FiberRunner® Cable Routing System provides pathway components that allow the system to be configured in compliance with these standards.</p>

\*VISIO is a registered trademark of Microsoft Corporation in the United States and/or other countries.

\*\*AutoCAD is a registered trademark of Autodesk, Inc.

---

## Panduit Difference

Panduit is committed to delivering a consistently high level of quality and service the world over. With a presence in more than 100 countries, local Panduit sales representatives and technical specialists offer guidance and support that bring value to your business. Our global supply chain, which includes manufacturing, customer service, logistics, and distribution partners, provides prompt response to your inquiries and streamlines delivery to any worldwide destination.

---

## Our most important connection is with you.

We have the knowledge and experience to help you make the most of your infrastructure investment.

[www.panduit.com](http://www.panduit.com)

### Let's Connect

[www.panduit.com/en/support/contact-us.html](http://www.panduit.com/en/support/contact-us.html)