

THIS COPY IS PROVIDED ON A RESTRICTED BASIS AND IS NOT TO BE USED IN ANY WAY DETRIMENTAL TO THE INTERESTS OF PANDUIT CORP.

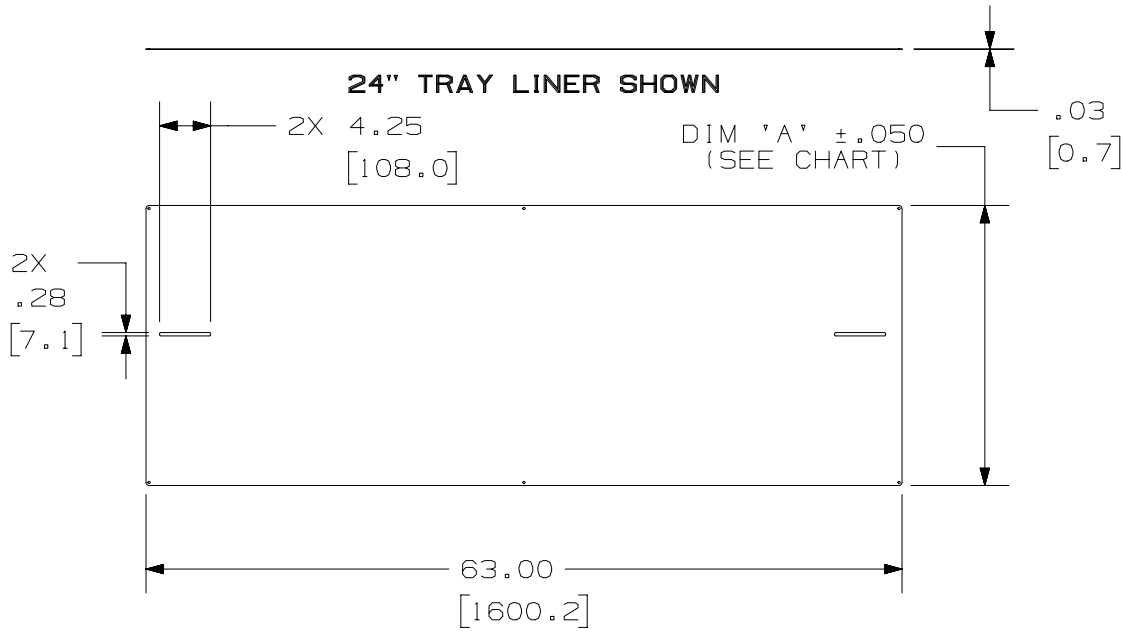

PANDUIT PART NUMBER	DIMENSION 'A'	NOMINAL SIZE	WEIGHT
PWBTL4**	3.33 [84.6]	4" X 63" [100 X 1600]	4.0 LBS (1814.4 g)
PWBTL6**	5.33 [135.4]	6" X 63" [150 X 1600]	6.0 LBS (2721.6 g)
PWBTL8**	7.33 [186.2]	8" X 63" [200 X 1600]	8.0 LBS (3628.7 g)
PWBTL12**	11.33 [287.8]	12" X 63" [300 X 1600]	12.0 LBS (5443.1 g)
PWBTL18**	17.33 [440.2]	18" X 63" [450 X 1600]	18.0 LBS (8164.7 g)
PWBTL24**	23.33 [592.6]	24" X 63" [600 X 1600]	24.0 LBS (10886.2 g)

**NOTES:**

- PART INCLUDES:  
 2- TRAY LINER (TOTAL OF 126")  
 4- BASKET CLIP WITH PEM  
 4- 1/4-20 X 3/4" LONG PHILLIPS TRUSS HEAD SCREW
- DIMENSIONS IN PARENTHESES ARE METRIC.
- \*\*= AVAILABLE IN PRE-GALVANIZED, BLACK, OR WHITE POWDER COATED FINISHES

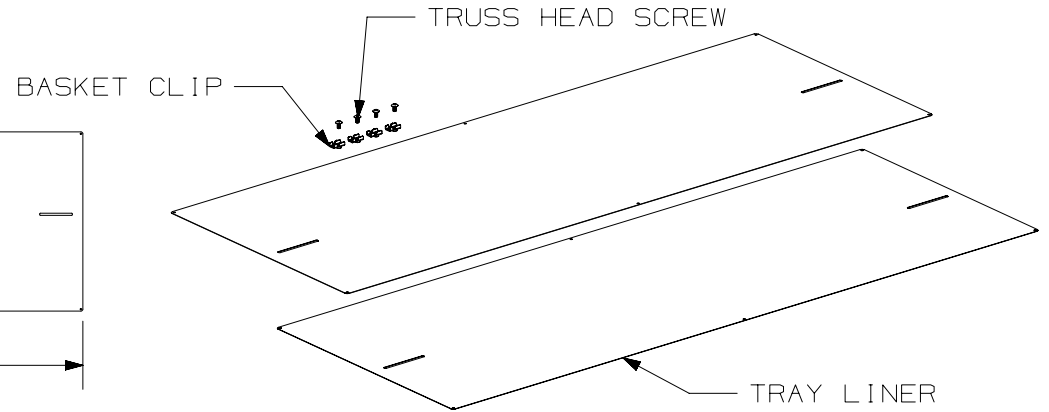
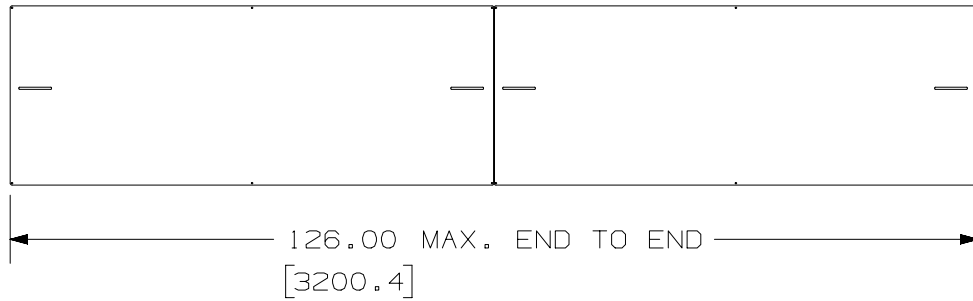

REV	DATE	BY	CHK	APR	DESCRIPTION	ECN
00C	12-14-23	SAT	DWR	EB	B. UPDATED TITLE. B. ADDED NOMINAL METRIC DIMENSIONS	00510EAC-DC
00B	3/7/22	JSP	DWR	ML	A. ADDED END TO END VIEW	00510EAC-DC
00A	02-11-21	SAT	DWR	ML	INITIAL RELEASE	00510EAC-DC

TITLE						
<b>WIRE BASKET METAL TRAY LINER</b>						
CUSTOMER DRAWING						
ITEM REVISION NAME					<b>PANDUIT</b>	
00510EAC/00						
DATASET FILE NAME					MATERIAL:	
00510EAC_DC/00C						
UNLESS OTHERWISE SPECIFIED, DIMENSIONAL TOLERANCES ARE: IN (mm)					STEEL	
.X ±		.XXX ±				
.XX ± .05 [1.3]		ANGLES ± 5 °			DRAWING NUMBER: 00510EAC-DC	
		THIRD ANGLE PROJECTION				
DRAWN BY	DATE	CHK	SCALE	SHT 1 OF 1		
SAT	02-08-21	DWR	NONE	A		