

THIS COPY IS PROVIDED ON A RESTRICTED BASIS AND IS NOT TO BE USED IN ANY WAY DETRIMENTAL TO THE INTERESTS OF PANDUIT CORP.

| PANDUIT P/N | WEIGHT |
|-------------|----------------------------|
| PWBWMN** | 1.03 LBS/SET (470g)/SET |

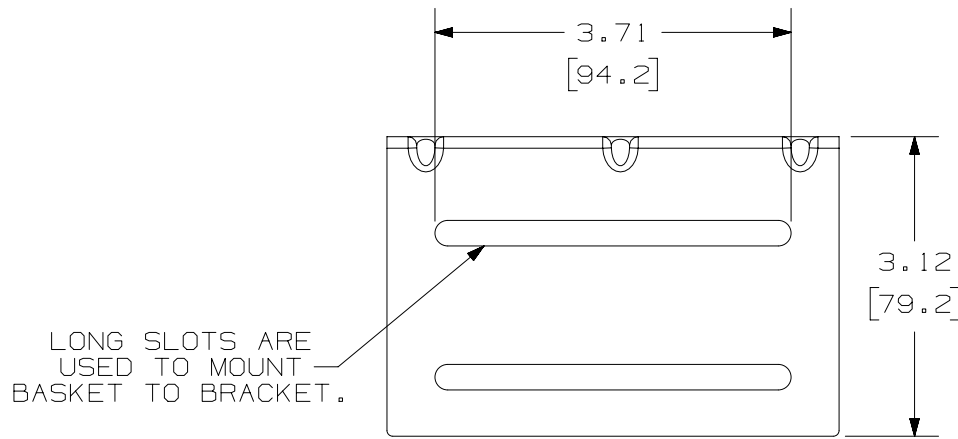

NOTES:

- VISIT OUR ON-LINE CATALOG AT WWW.PANDUIT.COM FOR A LIST OF CURRENT PARTS APPLICABLE FOR USE WITH THIS PRODUCT.
- DIMENSIONS IN [] ARE METRIC.
- PART NUMBER INCLUDES 2 BRACKETS.
- USE (4) PWBHK** FOR FASTENING TO BASKET. PWBHK** SOLD SEPARATELY.
- USE CUSTOMER SUPPLIED 1/4" OR 6mm HARDWARE TO FASTEN TO WALL.
- **= BL (BLACK POWDER COAT), WH (WHITE POWDER COAT), OR EZ (CLEAR ZINC)
- ALL MATERIALS AND COMPONENTS USED MEET THE MATERIAL RESTRICTIONS OF RoHS (EUROPEAN DIRECTIVE 2011/65/EC ON THE RESTRICTION OF HAZARDOUS SUBSTANCES) AS PROPOSED BY THE RoHS TECHNICAL ADAPTATION COMMITTEE.

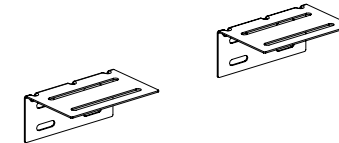
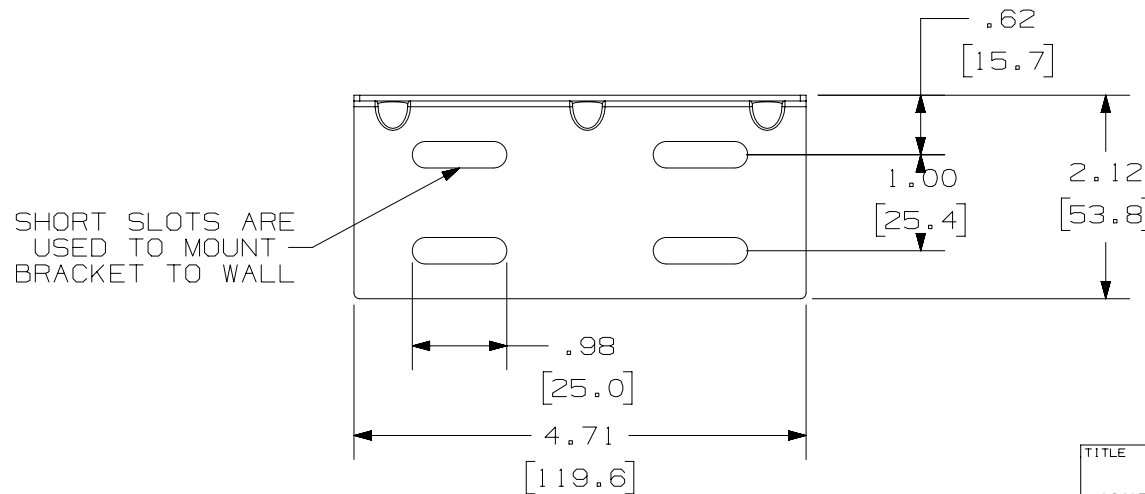

| | | | | | | | | | |
|--|--|----------|--------|-----|-----------------|----------------|--|-------------|--|
| TITLE | | | | | | | | | |
| WIRE BASKET WALL TERMINATION BRACKET, NARROW | | | | | | | | | |
| CUSTOMER DRAWING | | | | | | | | | |
| ITEM REVISION NAME | | | | | 00510JAA/00 | | | | |
| DATASET FILE NAME | | | | | 00510JAA_DC/00C | | | | |
| MATERIAL | | | C.R.S. | | | DRAWING NUMBER | | 00510JAA-DC | |
| DRAWN BY | | DATE | | CHK | | SCALE | | SIZE | |
| JSP | | 12/15/20 | | DWW | | NONE | | A | |
| SHEET 1 OF 1 | | | | | | | | | |

| REV | DATE | BY | CHK | APR | DESCRIPTION | ECN |
|-----|----------|-----|-----|-----|-------------------|-------------|
| 00C | 12-14-23 | SAT | DWR | EB | B. UPDATED TITLE. | 00510JAA-DC |
| 00B | 3/18/22 | JSP | DWR | ML | A. UPDATED NOTES | 00510JAA-DC |
| 00A | 12/15/20 | JSP | DWW | ML | INITIAL RELEASE | 00510JAA-DC |

A-SIZE CUSTOMER