

THIS COPY IS PROVIDED ON A RESTRICTED BASIS AND IS NOT TO BE USED IN ANY WAY DETRIMENTAL TO THE INTERESTS OF PANDUIT CORP.



PANDUIT PART NO.	WEIGHT
R4PFL	2.2 LBS. [1 Kg]

NOTES:

- VISIT OUR ON-LINE CATALOG AT WWW.PANDUIT.COM FOR A LIST OF CURRENT PARTS APPLICABLE FOR USE WITH THIS PRODUCT.
- DIMENSIONS IN PARENTHESES ARE METRIC (mm).
- PARTS SUPPLIED:
 1- FINGER BRACKET
 1- SI FINGER 11-R
 1- #12-24 x .500" HEX HEAD BONDING SCREW (PACK OF 4)
 1- INSTRUCTION SHEET

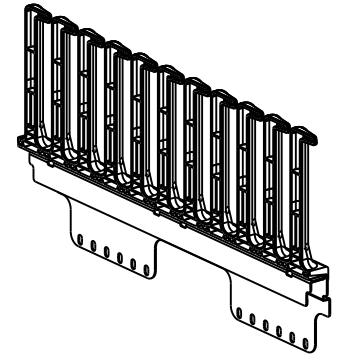
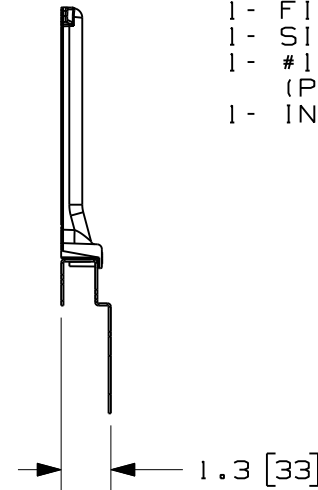
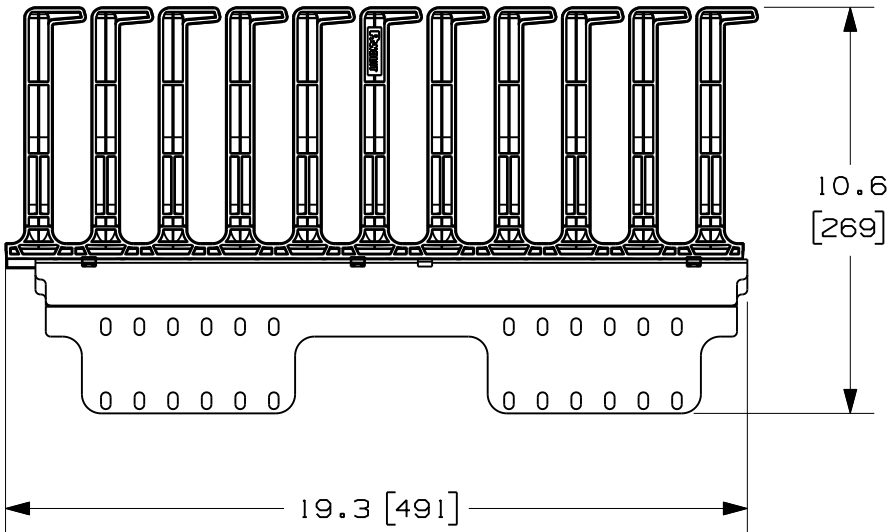

MODEL FILENAME	10V172BH/00.PRT
CAD FILENAME/LAYERS	10V172BH_DC/00A.PRT

PANDUIT CORP. TINLEY PARK, ILLINOIS
 (R4PFL) FINGER BRACKET - LEFT
 CUSTOMER DRAWING

UNLESS OTHERWISE SPECIFIED, DIMENSIONAL TOLERANCES ARE: INCHES X.X +/- 0.03 X.XX +/- 0.015 X.XXX +/- 0.005	[METRIC - MILLIMETER] X.X +/- 0.8 X.X +/- 0.4 X.XX +/- 0.13	ANGLE +/- 1°	UNLESS OTHERWISE SPECIFIED, ALL DIMENSIONS ARE GIVEN IN INCHES, THIRD ANGLE PROJECTION.
---	---	--------------	---

DRAWN BY PM	MAT'L: N/A	SCALE NONE
DATE 10-20-10		DRAWING NO. 10V172BH-DC
CHK'D		DWG A SIZE

OOA	10-20-10	PM	SRK	RELEASED TO PRODUCTION	10V172BH-DC					
REV	DATE	BY	CHK	DESCRIPTION	ECN	R	CUST	SUP	OTH	