

THIS COPY IS PROVIDED ON A RESTRICTED BASIS AND IS NOT TO BE USED IN ANY WAY DETRIMENTAL TO THE INTERESTS OF PANDUIT CORP.

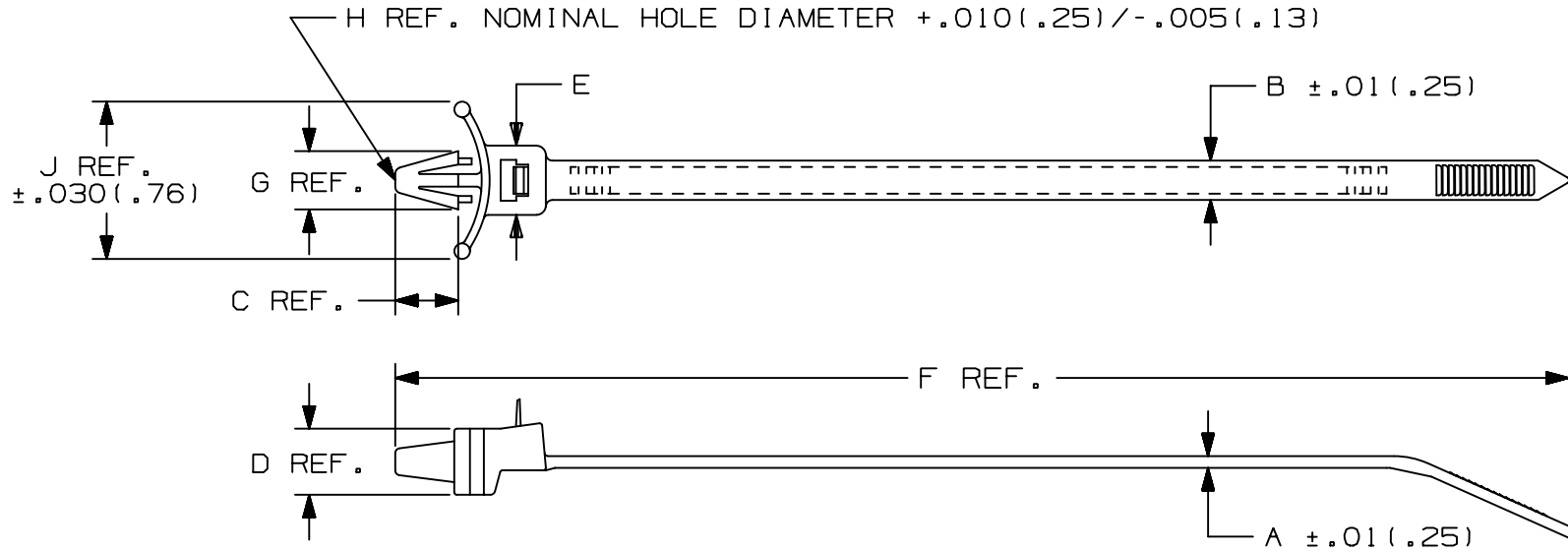

PANDUIT PART NO.*	BUNDLE DIA.		A in (mm)	B in (mm)	C in (mm)	D in (mm)	E in (mm)	F in (mm)	G in (mm)	H in (mm)	J in (mm)	MAX. PANEL THICKNESS in (mm)	MIN. LOOP TENSILE lbs (N)	CROSS SECTION	WEIGHT 100 pcs lbs (g)
	MIN. in (mm)	MAX. in (mm)													
PRWP1.5S-30	.06 (1.5)	1.50 (38.1)	.052 (1.3)	.190 (4.8)	.300 (7.6)	.37 (9.4)	.320 (8.1)	6.8 (173)	.33 (8.4)	.250 (6.4)	.74 (18.8)	.105 (.27)	50 (222)	STANDARD	.34 (154)

NOTES:

- \*1) SEE CURRENT PRICE SHEET FOR PART NUMBER SUFFIX DESIGNATION FOR PACKAGE SIZE & PART COLOR.
- 2) MEETS THE REQUIREMENTS OF FEDERAL SPECIFICATION LP-410 SECTION 4.3
- 3) RECOGNIZED UNDER THE COMPONENT PROGRAM OF UNDERWRITERS LABORATORIES INC.

DIMENSIONS IN PARENTHESES ARE IN METRIC UNITS

PANDUIT CORP. TINLEY PARK, ILLINOIS

RELEASING WING PUSH MOUNT CLAMP  
PRWP

UNLESS OTHERWISE SPECIFIED,  
DIMENSIONAL TOLERANCES ARE:  
(.X)±.1(2.5) (.XXX)±.020(.51)  
(.XX)±.02(.5) ANGLES±° ---

UNLESS OTHERWISE SPECIFIED,  
ALL DIMENSIONS ARE GIVEN  
IN INCHES, THIRD ANGLE PROJECTION.

DRAWN BY  
WKS

MAT'L:

SCALE  
NONE

DATE  
3-31-87

HEAT STABILIZED  
NYLON 6/6

DRAWING NO.  
SS-19349

DWG  
A  
SIZE

10 1/21/04 JABO  
CHANGED FORMAT FOR CONSISTENCY  
SEE ECN FOR DETAILS

19349 10

CHK'D  
HVP

REV	DATE	BY	CHK	DESCRIPTION	ECN	R	CUST	SUP
10	1/21/04	JABO		CHANGED FORMAT FOR CONSISTENCY SEE ECN FOR DETAILS	19349	10		