

THIS COPY IS PROVIDED ON A RESTRICTED BASIS AND IS NOT TO BE USED IN ANY WAY DETRIMENTAL TO THE INTERESTS OF PANDUIT CORP.

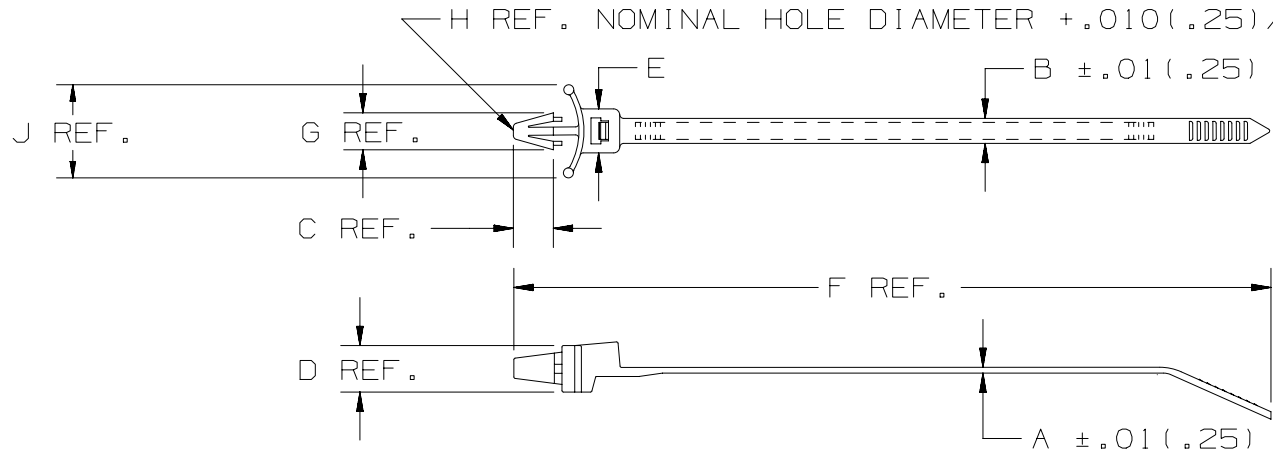

PANDUIT PART NO.	BUNDLE DIAMETER		A	B	REF. C	REF. D	E	REF. F	REF. G	REF. H	REF. J	MAX PANEL THICKNESS in (mm)	MIN. LOOP TENSILE lbs (N)	CROSS SECTION	WEIGHT 100 pcs. lbs (g)
	MIN. in (mm)	MAX. in (mm)													
PLWP1M	.06 (1.5)	.87 (22.1)	.044 (1.1)	.098 (2.5)	.230 (5.8)	.220 (5.6)	.180 (4.6)	4.3 (109)	.240 (6.1)	.187 (4.7)	.53 (13.5)	.093 (2.4)	18 (80)	MINIATURE	.11 (50)
PLWP1.5I	.06 (1.5)	1.25 (31.8)	.045 (1.2)	.135 (3.4)	.230 (5.8)	.280 (7.1)	.240 (6.1)	6.0 (152)	.240 (6.1)	.187 (4.7)	.450 (11.4)	.093 (2.4)	40 (178)	INTERMEDIATE	.17 (77)
PLWP1S	.06 (1.5)	1.00 (25.4)	.052 (1.3)	.190 (4.8)	.300 (7.6)	.370 (9.4)	.316 (8.0)	5.2 (132)	.330 (8.4)	.250 (6.4)	.74 (18.8)	.105 (2.7)	50 (222)	STANDARD	.29 (132)
PLWP1.5S	.06 (1.5)	1.50 (38.1)	.052 (1.3)	.190 (4.8)	.300 (7.6)	.370 (9.4)	.316 (8.0)	6.8 (173)	.330 (8.4)	.250 (6.4)	.74 (18.8)	.105 (2.7)	50 (222)	STANDARD	.34 (154)
PLWP2S	.06 (1.5)	1.75 (44.5)	.052 (1.3)	.190 (4.8)	.300 (7.6)	.370 (9.4)	.316 (8.0)	7.8 (198)	.330 (8.4)	.250 (6.4)	.74 (18.8)	.105 (2.7)	50 (222)	STANDARD	.37 (168)

NOTES:

1. RECOGNIZED UNDER THE COMPONENT PROGRAM OF UNDERWRITERS LABORATORIES INC.

DIMENSIONS IN PARENTHESES ARE IN METRIC UNITS

REV	DATE	BY	CHK	APR	DESCRIPTION	ECN	DRAWN BY	DATE	CHK	SCALE	SHT 1 OF 1	SIZE
14	11/25/13	BWG	JADE	JADE	REVISED REF. NOTES. SEE ECN FOR COMPLETE DETAILS.	SS-17564/14	C.HARVELL	05/26/92	HVP	NONE	SHT 1 OF 1	A

TITLE: LOCKING WING PUSH MOUNT TIE - PLWP SERIES

CUSTOMER DRAWING

ITEM REVISION NAME: W10001BI/01

DATASET FILE NAME: W10001BI/01-SS_17564_REV14

UNLESS OTHERWISE SPECIFIED, DIMENSIONAL TOLERANCES ARE: IN [mm]

.x ± .1 (2.5) .xxx ± .020 (.51)

.xx ± .02 (.5) ANGLES ± - - - - -

MATERIAL: NYLON 6.6

DRAWING NUMBER: SS-17564

THIRD ANGLE PROJECTION

D10100DA/16