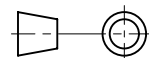

THIS COPY IS PROVIDED ON A RESTRICTED BASIS AND IS NOT TO BE USED IN ANY WAY DETRIMENTAL TO THE INTERESTS OF PANDUIT CORP.

| PART NO. | DESCRIPTION | FRAME HEIGHT | FRAME DEPTH | E-RAIL MAXIMUM SPACING | SIDE PANELS | FINGER KIT QTY | CABINET WEIGHT FULLY UNPACKAGED | CABINET WEIGHT SHIPPING WEIGHT |
|----------|--|------------------|----------------|--|-------------|----------------|---------------------------------|--------------------------------|
| DAE8219* | NET-VERSE D-TYPE CABINET 800mm WIDE X 42RU X 1000mm DEEP | 1998.0 [78.76] | 1000.0 (39.37) | 738 (29.1) WITH CMB 871 (34.3) WITHOUT CMB | 00 | 00 | 102 Kg/EACH 225 LBS/EACH | 123 Kg/EACH 270 LBS/EACH |
| DAE8212* | NET-VERSE D-TYPE CABINET 800mm WIDE X 42RU X 1000mm DEEP | 1998.0 [78.76] | 1000.0 (39.37) | 738 (29.1) WITH CMB 871 (34.3) WITHOUT CMB | 04 | 00 | 141 Kg/EACH 311 LBS/EACH | 161 Kg/EACH 356 LBS/EACH |
| DAE8229* | NET-VERSE D-TYPE CABINET 800mm WIDE X 42RU X 1200mm DEEP | 1998.0 [78.76] | 1200.0 (47.24) | 938 (36.9) WITH CMB 1071 (42.2) WITHOUT CMB | 00 | 00 | 107 Kg/EACH 237 LBS/EACH | 130 Kg/EACH 287 LBS/EACH |
| DAE8222* | NET-VERSE D-TYPE CABINET 800mm WIDE X 42RU X 1200mm DEEP | 1998.0 [78.76] | 1200.0 (47.24) | 938 (36.9) WITH CMB 1071 (42.2) WITHOUT CMB | 04 | 00 | 152 Kg/EACH 336 LBS/EACH | 175 Kg/EACH 386 LBS/EACH |
| DAE8519* | NET-VERSE D-TYPE CABINET 800mm WIDE X 45RU X 1000mm DEEP | 2131.4 [83.91] | 1000.0 (39.37) | 738 (29.1) WITH CMB 871 (34.3) WITHOUT CMB | 00 | 00 | 105 Kg/EACH 232 LBS/EACH | 126 Kg/EACH 278 LBS/EACH |
| DAE8512* | NET-VERSE D-TYPE CABINET 800mm WIDE X 45RU X 1000mm DEEP | 2131.4 [83.91] | 1000.0 (39.37) | 738 (29.1) WITH CMB 871 (34.3) WITHOUT CMB | 04 | 00 | 157 Kg/EACH 345 LBS/EACH | 180 Kg/EACH 396 LBS/EACH |
| DAE8529* | NET-VERSE D-TYPE CABINET 800mm WIDE X 45RU X 1200mm DEEP | 2131.4 [83.91] | 1200.0 (47.24) | 938 (36.9) WITH CMB 1071 (42.2) WITHOUT CMB | 00 | 00 | 110 Kg/EACH 243 LBS/EACH | 133 Kg/EACH 294 LBS/EACH |
| DAE8522* | NET-VERSE D-TYPE CABINET 800mm WIDE X 45RU X 1200mm DEEP | 2131.4 [83.91] | 1200.0 (47.24) | 938 (36.9) WITH CMB 1071 (42.2) WITHOUT CMB | 04 | 00 | 166 Kg/EACH 365 LBS/EACH | 189 Kg/EACH 417 LBS/EACH |
| DAE8819* | NET-VERSE D-TYPE CABINET 800mm WIDE X 48RU X 1000mm DEEP | 2264.7 [89.16] | 1000.0 (39.37) | 738 (29.1) WITH CMB 871 (34.3) WITHOUT CMB | 00 | 00 | 108 Kg/EACH 238 LBS/EACH | 129 Kg/EACH 284 LBS/EACH |
| DAE8812* | NET-VERSE D-TYPE CABINET 800mm WIDE X 48RU X 1000mm DEEP | 2264.7 [89.16] | 1000.0 (39.37) | 738 (29.1) WITH CMB 871 (34.3) WITHOUT CMB | 04 | 00 | 162 Kg/EACH 357 LBS/EACH | 183 Kg/EACH 403 LBS/EACH |
| DAE8829* | NET-VERSE D-TYPE CABINET 800mm WIDE X 48RU X 1200mm DEEP | 2264.7 [89.16] | 1200.0 (47.24) | 938 (36.9) WITH CMB 1071 (42.2) WITHOUT CMB | 00 | 00 | 113 Kg/EACH 249 LBS/EACH | 136 Kg/EACH 300 LBS/EACH |
| DAE8822* | NET-VERSE D-TYPE CABINET 800mm WIDE X 48RU X 1200mm DEEP | 2264.7 [89.16] | 1200.0 (47.24) | 938 (36.9) WITH CMB 1071 (42.2) WITHOUT CMB | 04 | 00 | 180 Kg/EACH 397 LBS/EACH | 203 Kg/EACH 448 LBS/EACH |

NOTE: *DENOTES COLOR - ADD SUFFIX "B" FOR BLACK AND "W" FOR WHITE.

| | | | | | | | | | | | | | |
|--|------|----|-----|-----|-------------|--|----------|---------|--|-------|---------------------------------------|--|------|
| | | | | | | TITLE NET-VERSE D-TYPE ENHANCED CABINET 800 WIDE X 42, 45 & 48 X 1000mm/1200mm DEEP WITHOUT/WITH FINGER KIT (DAE8**** & DAE8****F) CUSTOMER DRAWING | | | | | | | |
| | | | | | | ITEM REVISION NAME 00568EAD/00 | | |  | | | | |
| | | | | | | DATASET FILE NAME 00568EAD_DC/00A | | | | | | | |
| | | | | | | MATERIAL: N/A | | | | | | | |
| 00A 12-4-19 MES PATR SJP SEE SHEET ONE FOR REVISIONS | | | | | | V09002DP | | |  THIRD ANGLE PROJECTION | | DRAWING NUMBER: 00568EAD-DC | | |
| REV | DATE | BY | CHK | APR | DESCRIPTION | ECN | DRAWN BY | DATE | CHK | SCALE | SHT 2 OF 8 | | SIZE |
| | | | | | | | MES | 12-4-19 | PATR | NONE | | | A |

D110100DA/16

THIS COPY IS PROVIDED ON A RESTRICTED BASIS AND IS NOT TO BE USED IN ANY WAY DETRIMENTAL TO THE INTERESTS OF PANDUIT CORP.

| PART NO. | DESCRIPTION | FRAME HEIGHT | FRAME DEPTH | E-RAIL MAXIMUM SPACING | SIDE PANELS | FINGER KIT QTY | CABINET WEIGHT FULLY UNPACKAGED | CABINET WEIGHT SHIPPING WEIGHT |
|-----------|--|------------------|----------------|--|-------------|----------------|---------------------------------|--------------------------------|
| DAE8219*F | NET-VERSE D-TYPE CABINET 800mm WIDE X 42RU X 1000mm DEEP WITH FINGER KIT | 1998.0 (78.76) | 1000.0 (39.37) | 738 (29.1) WITH CMB 871 (34.3) WITHOUT CMB | 00 | 01 | 105 Kg/EACH 231 LBS/EACH | 126 Kg/EACH 276 LBS/EACH |
| DAE8212*F | NET-VERSE D-TYPE CABINET 800mm WIDE X 42RU X 1000mm DEEP WITH FINGER KIT | 1998.0 (78.76) | 1000.0 (39.37) | 738 (29.1) WITH CMB 871 (34.3) WITHOUT CMB | 04 | 01 | 144 Kg/EACH 317 LBS/EACH | 164 Kg/EACH 362 LBS/EACH |
| DAE8229*F | NET-VERSE D-TYPE CABINET 800mm WIDE X 42RU X 1200mm DEEP WITH FINGER KIT | 1998.0 (78.76) | 1200.0 (47.24) | 938 (36.9) WITH CMB 1071 (42.2) WITHOUT CMB | 00 | 01 | 110 Kg/EACH 242 LBS/EACH | 133 Kg/EACH 293 LBS/EACH |
| DAE8222*F | NET-VERSE D-TYPE CABINET 800mm WIDE X 42RU X 1200mm DEEP WITH FINGER KIT | 1998.0 (78.76) | 1200.0 (47.24) | 938 (36.9) WITH CMB 1071 (42.2) WITHOUT CMB | 04 | 01 | 155 Kg/EACH 342 LBS/EACH | 178 Kg/EACH 392 LBS/EACH |
| DAE8519*F | NET-VERSE D-TYPE CABINET 800mm WIDE X 45RU X 1000mm DEEP WITH FINGER KIT | 2131.4 (83.91) | 1000.0 (39.37) | 738 (29.1) WITH CMB 871 (34.3) WITHOUT CMB | 00 | 01 | 108 Kg/EACH 238 LBS/EACH | 129 Kg/EACH 284 LBS/EACH |
| DAE8512*F | NET-VERSE D-TYPE CABINET 800mm WIDE X 45RU X 1000mm DEEP WITH FINGER KIT | 2131.4 (83.91) | 1000.0 (39.37) | 738 (29.1) WITH CMB 871 (34.3) WITHOUT CMB | 04 | 01 | 160 Kg/EACH 351 LBS/EACH | 183 Kg/EACH 402 LBS/EACH |
| DAE8529*F | NET-VERSE D-TYPE CABINET 800mm WIDE X 45RU X 1200mm DEEP WITH FINGER KIT | 2131.4 (83.91) | 1200.0 (47.24) | 938 (36.9) WITH CMB 1071 (42.2) WITHOUT CMB | 00 | 01 | 113 Kg/EACH 249 LBS/EACH | 136 Kg/EACH 300 LBS/EACH |
| DAE8522*F | NET-VERSE D-TYPE CABINET 800mm WIDE X 45RU X 1200mm DEEP WITH FINGER KIT | 2131.4 (83.91) | 1200.0 (47.24) | 938 (36.9) WITH CMB 1071 (42.2) WITHOUT CMB | 04 | 01 | 169 Kg/EACH 371 LBS/EACH | 192 Kg/EACH 423 LBS/EACH |
| DAE8819*F | NET-VERSE D-TYPE CABINET 800mm WIDE X 48RU X 1000mm DEEP WITH FINGER KIT | 2264.7 (89.16) | 1000.0 (39.37) | 738 (29.1) WITH CMB 871 (34.3) WITHOUT CMB | 00 | 01 | 111 Kg/EACH 245 LBS/EACH | 132 Kg/EACH 291 LBS/EACH |
| DAE8812*F | NET-VERSE D-TYPE CABINET 800mm WIDE X 48RU X 1000mm DEEP WITH FINGER KIT | 2264.7 (89.16) | 1000.0 (39.37) | 738 (29.1) WITH CMB 871 (34.3) WITHOUT CMB | 04 | 01 | 165 Kg/EACH 264 LBS/EACH | 186 Kg/EACH 410 LBS/EACH |
| DAE8829*F | NET-VERSE D-TYPE CABINET 800mm WIDE X 48RU X 1200mm DEEP WITH FINGER KIT | 2264.7 (89.16) | 1200.0 (47.24) | 938 (36.9) WITH CMB 1071 (42.2) WITHOUT CMB | 00 | 01 | 116 Kg/EACH 256 LBS/EACH | 139 Kg/EACH 306 LBS/EACH |
| DAE8822*F | NET-VERSE D-TYPE CABINET 800mm WIDE X 48RU X 1200mm DEEP WITH FINGER KIT | 2264.7 (89.16) | 1200.0 (47.24) | 938 (36.9) WITH CMB 1071 (42.2) WITHOUT CMB | 04 | 01 | 183 Kg/EACH 404 LBS/EACH | 206 Kg/EACH 454 LBS/EACH |

NOTE: *DENOTES COLOR - ADD SUFFIX "B" FOR BLACK AND "W" FOR WHITE.

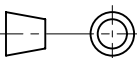
| | | | | | | | | | | | | |
|--|-------------|-----------|------------|------------|--------------------|--|-----------------|---|------------|--------------|------------------------|-------------|
| | | | | | | TITLE NET-VERSE D-TYPE ENHANCED CABINET 800 WIDE X 42, 45 & 48 X 1000mm/1200mm DEEP WITHOUT/WITH FINGER KIT (DAE8**** & DAE8****F) CUSTOMER DRAWING | | | | | | |
| | | | | | | ITEM REVISION NAME 00568EAD/00 | |  | | | | |
| | | | | | | DATASET FILE NAME 00568EAD_DC/00A | | | | | | |
| | | | | | | | | MATERIAL: N/A | | | | |
| 00A 12-4-19 MES PATR SJP SEE SHEET ONE FOR REVISIONS | | | | | | V09002DP | |  THIRD ANGLE PROJECTION | | | | |
| REV | DATE | BY | CHK | APR | DESCRIPTION | ECN | DRAWN BY | DATE | CHK | SCALE | DRAWING NUMBER: | SIZE |
| | | | | | | | MES | 12-4-19 | PATR | NONE | SHT 3 OF 8 | A |

917000DA/16

THIS COPY IS PROVIDED ON A RESTRICTED BASIS AND IS NOT TO BE USED IN ANY WAY DETRIMENTAL TO THE INTERESTS OF PANDUIT CORP.

1084 [42.7]
1000mm DEPTH

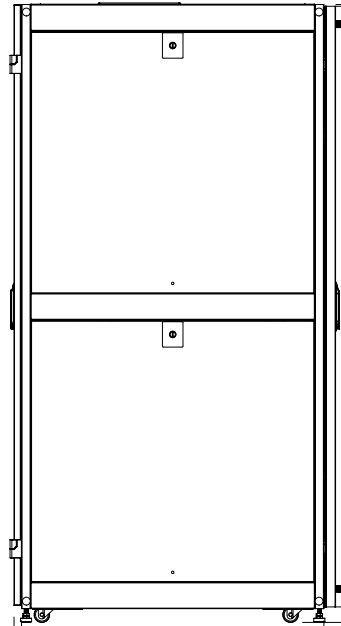

LEFT VIEW

798
[31.4]

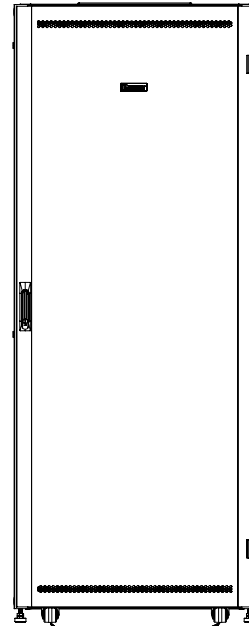

FRONT VIEW

1284 [50.6]
1200mm DEPTH

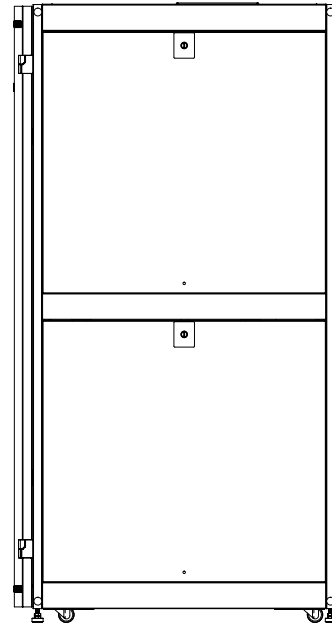

RIGHT VIEW

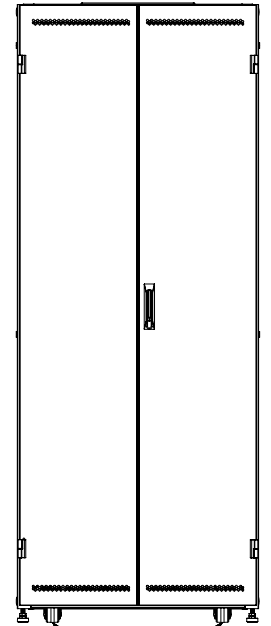

REAR VIEW

HEIGHT WITH CASTERS

42RU
2045
[80.5]

45RU
2178
[85.8]

48RU
2311
[90.9]

REAR DOOR DEPTH [1.0]

59 FRONT DOOR DEPTH [2.3]

SWIVEL FRONT CASTERS

SWIVEL REAR CASTERS

TITLE
NET-VERSE D-TYPE ENHANCED CABINET 800 WIDE X 42, 45 & 48 X 1000mm/1200mm DEEP WITHOUT/WITH FINGER KIT (DAE8** & DAE8****F)**
CUSTOMER DRAWING

ITEM REVISION NAME
00568EAD/00

DATASET FILE NAME
00568EAD_DC/00A

PANDUIT

MATERIAL:
N/A

DRAWING NUMBER:
00568EAD-DC

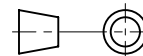

THIRD ANGLE PROJECTION

| | | | | | | | | | | |
|-----|---------|-----|------|-----|-----------------------------|--|--|--|----------|--|
| | | | | | | | | | | |
| | | | | | | | | | | |
| | | | | | | | | | | |
| | | | | | | | | | | |
| | | | | | | | | | | |
| 00A | 12-4-19 | MES | PATR | SJP | SEE SHEET ONE FOR REVISIONS | | | | V09002DP | |

| REV | DATE | BY | CHK | APR | DESCRIPTION | ECN |
|-----|------|----|-----|-----|-------------|-----|
| | | | | | | |

| | | | | | |
|-----------------|-----------------|-------------|---------------|------------------------------|-----------|
| DRAWN BY MES | DATE 12-4-19 | CHK PATR | SCALE NONE | DRAWING NUMBER SHT 4 OF 8 | SIZE A |
|-----------------|-----------------|-------------|---------------|------------------------------|-----------|

D10100DA/16

THIS COPY IS PROVIDED ON A RESTRICTED BASIS AND IS NOT TO BE USED IN ANY WAY DETRIMENTAL TO THE INTERESTS OF PANDUIT CORP.

42RU 46.3 [1.8]
45RU 112.9 [4.4]
48RU 24.2 [1.0]

FROM CENTER OF TOP MOUNTING BUTTON TO EIA MOUNTING BEAM

42RU 137.5 [5.4]
45RU 204.1 [8.0]
48RU 114.2 [4.5]
FROM CENTER OF TOP MOUNTING BUTTON TO TOP CAP

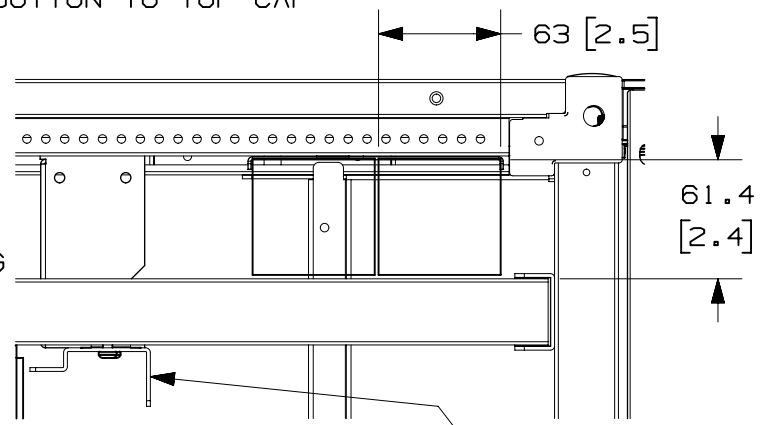
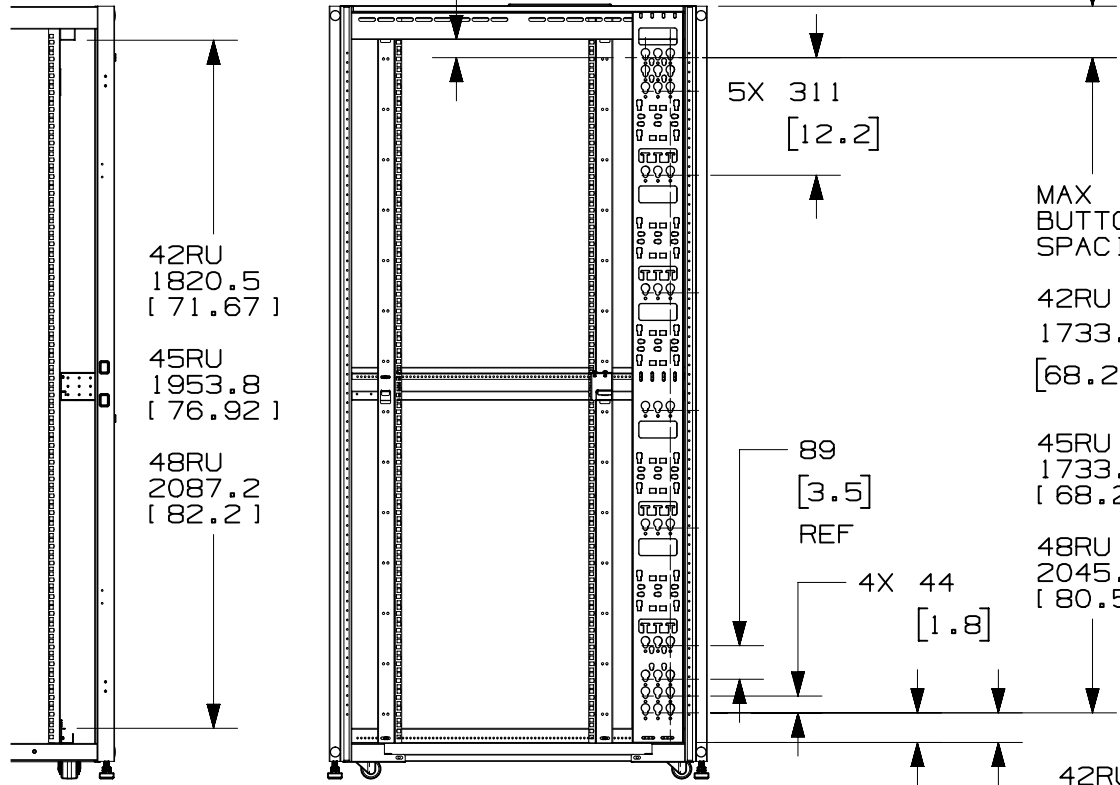

TOP VIEW

PDU FIT:
MAXIMUM WIDTH OF 63mm FOR (2) PDU'S MOUNTED ON ONE BRACKET, OR (1) 130mm WIDE PDU.

PDU'S GREATER THAN 61.5mm (42RU, 45RU & 48RU) DEEP WILL BE BLOCKED BY EIA RAIL MOUNTING BEAMS, AS SHOWN IN VIEWS ON LEFT.

PDU'S GREATER THAN 129.8mm (42RU, 45RU & 48RU) DEEP WILL ENTER EIA AREA BEHIND REAR EQUIPMENT RAILS.

42RU 40.5 [1.6]
45RU 107.4 [4.22]
48RU 18.0 [0.7]
FROM CENTER OF BOTTOM MOUNTING BUTTON TO EIA MOUNTING BEAM

42RU 80.6 [3.17] TO FRAME
45RU 147.3 [5.79] TO FRAME
48RU 58.0 [1.10] TO FRAME

SOME COMPONENTS REMOVED FOR CLARITY

REAR VIEW

RIGHT VIEW

TITLE
NET-VERSE D-TYPE CABINET ENHANCED 800 WIDE X 42, 45 & 48 X 1000mm/1200mm DEEP WITHOUT/WITH FINGER KIT (DAE8** & DAE8****F)**
CUSTOMER DRAWING

ITEM REVISION NAME
00568EAD/00

DATASET FILE NAME
00568EAD_DC/00A



MATERIAL:
N/A

DRAWING NUMBER:
00568EAD-DC

| 00A | 12-4-19 | MES | PATR | SJP | SEE SHEET ONE FOR REVISIONS | V09002DP |
|-----|---------|-----|------|-----|-----------------------------|----------|
| REV | DATE | BY | CHK | APR | DESCRIPTION | ECN |

| | | | | | |
|-----------------|-----------------|-------------|---------------|------------------------------|-----------|
| DRAWN BY MES | DATE 12-4-19 | CHK PATR | SCALE NONE | DRAWING NUMBER SHT 8 OF 8 | SIZE A |
|-----------------|-----------------|-------------|---------------|------------------------------|-----------|

D10100DA/16