

2

1

THIS COPY IS PROVIDED ON A RESTRICTED BASIS AND IS NOT TO BE USED IN ANY WAY DETRIMENTAL TO THE INTERESTS OF PANDUIT CORP.

PANDUIT P/N	WEIGHT
UICFP6S	1.22 LB/10 PCS (550.9g/10 PCS)

NOTES:

- SEE CURRENT CATALOG FOR ADDITIONAL PART NUMBER SUFFIXES TO INDICATE COLOR AND OR PACKAGE QUANTITY.
- SEE CATALOG FOR COMPLETE LIST OF PARTS APPLICABLE FOR USE WITH THIS PART.
- DIMENSIONS IN PARENTHESES ARE IN METRIC.
- PART INCLUDES:
 - FACEPLATE
 - MOUNTING SCREWS
 - CLEAR SCREW COVER
 - COLOR COORDINATED SCREW COVER
 - CLEAR LABEL COVER

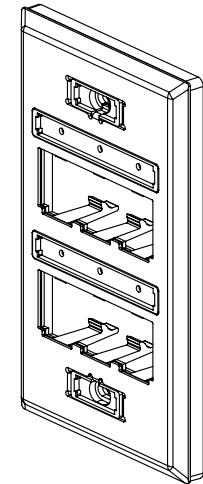
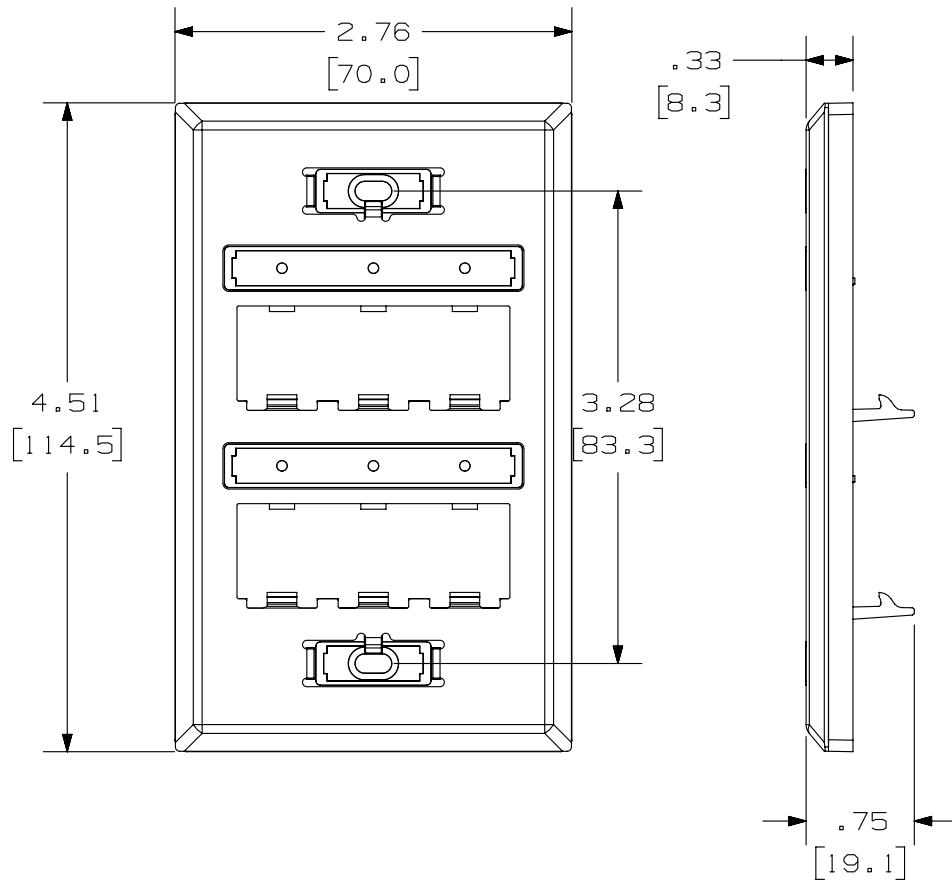

PART NUMBER		UICFP6S	
TITLE			
MINI-COM ULTIMATE ID 6 POSITION STAINLESS STEEL FACEPLATE			
CUSTOMER DRAWING			
ITEM REVISION NAME		M02237AC/05	
DATASET FILE NAME		M02237AC_DC/05B	
UNLESS OTHERWISE SPECIFIED, DIMENSIONAL TOLERANCES ARE: IN (mm)		MATERIAL:	
.x ± .xx ± .03 (.8)		FACEPLATE: 304 STAINLESS STEEL	
.xxx ± .010 (.3)		BACKING: ABS	
ANGLES ±		DRAWING NUMBER:	
THIRD ANGLE PROJECTION		02337-09	
DRAWN BY	DATE	CHK	SCALE
JSP	4-4-07	JCO	NONE
SHT 1 OF 1			SIZE
			A

1	5-20-14	BJN	JSP	MMR	REVISED & REDRAWN PREVIOUS REVISIONS REMVD FOR CLARITY	02337-09
REV	DATE	BY	CHK	APR	DESCRIPTION	ECN

2

1

D10100DA/14