

THIS COPY IS PROVIDED ON A RESTRICTED BASIS AND IS NOT TO BE USED IN ANY WAY DETRIMENTAL TO THE INTERESTS OF PANDUIT CORP.

NOTES:

1. VISIT OUR ON-LINE CATALOG AT [WWW.PANDUIT.COM](http://WWW.PANDUIT.COM) FOR A LIST OF CURRENT PARTS APPLICABLE FOR USE WITH THIS PRODUCT.
2. DIMENSIONS IN [ ] ARE METRIC.
3. WEIGHT: 1.7 LBS [ 757.1g ] (PER 100 SCREWS AND NUTS)
4. PART INCLUDES:  
 100- #12-24 ROUND HEAD SCREW  
 ZINC PLATED STEEL  
 100- #12-24 THREADED HEX NUT  
 ZINC PLATED STEEL
5. ALL PURCHASED ITEMS MUST CONFORM TO C2-0834PANDUIT SPECIFICATION FOR CHEMICAL SUBSTANCE TO BE CONTROLLED IN PRODUCT AND PACKAGING.

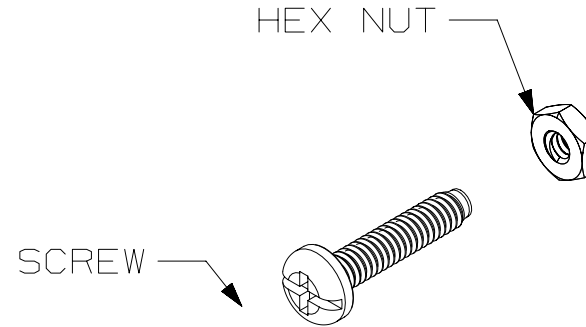
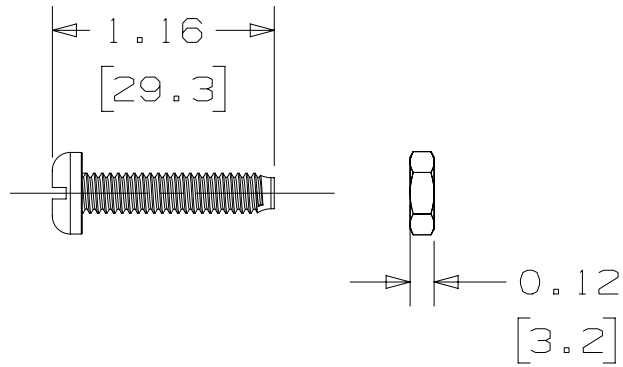

PART NUMBER		TRSRBK IT - C										
TITLE		THREADED RAIL RAIL KIT FOR STRAIN RELIEF BARS										
		CUSTOMER DRAWING										
ITEM REVISION NAME		01323ECA/00										
DATASET FILE NAME		01323ECA_DC/00A										
		THIRD ANGLE PROJECTION										
MATERIAL		SEE NOTE 4		DRAWING NUMBER								
				01085NBA - DC								
REV	DATE	BY	CHK	APR	DESCRIPTION	ECN	DRAWN BY	DATE	CHK	SCALE	SHEET 1 OF 1	SIZE
00A	08-04-23	JBO	MPOL	MMR	RELEASED TO RODUCTION	M09000TV	JBO	08-04-23	MPOL	NONE		A

A-SIZE CUSTOMER

2

1

2

1