

THIS COPY IS PROVIDED ON A RESTRICTED BASIS AND IS NOT TO BE USED IN ANY WAY DETRIMENTAL TO THE INTERESTS OF PANDUIT CORP.

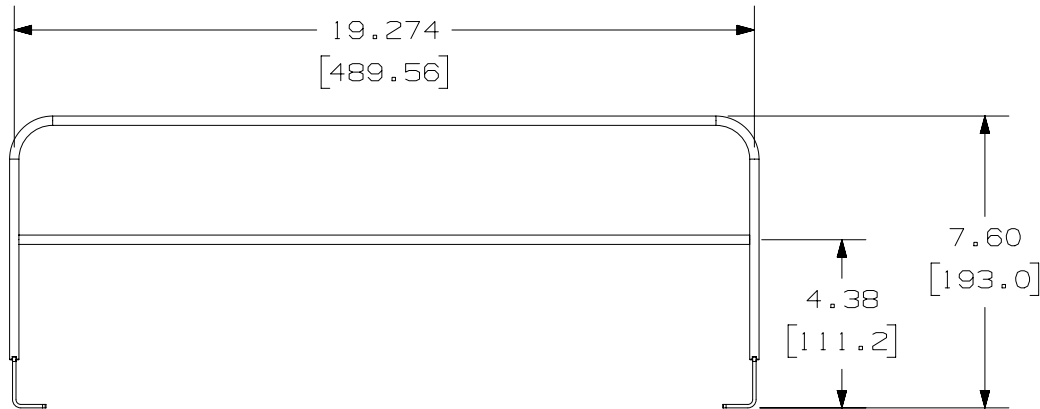



PANDUIT P/N	WEIGHT
SRB19D7BL	.71 LB/EACH PC (321.85 g/EACH PC)

NOTES:

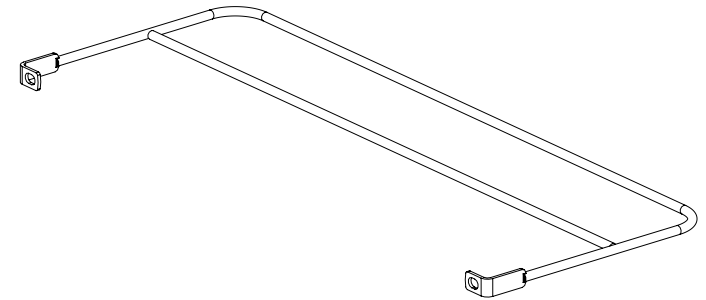
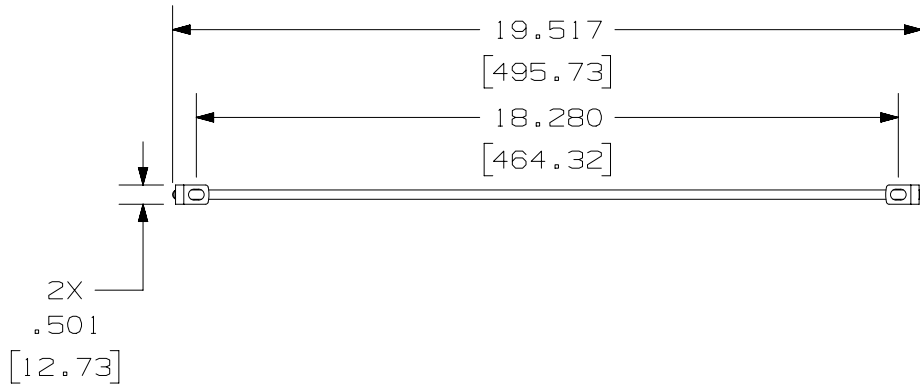
- SEE WWW.PANDUIT.COM FOR ADDITIONAL PART NUMBER SUFFIXES TO INDICATE COLOR AND OR PACKAGE QUANTITY.
- SEE WWW.PANDUIT.COM FOR COMPLETE LIST OF PARTS APPLICABLE FOR USE WITH THIS PART.
- DIMENSIONS IN PARENTHESES ARE IN METRIC.
- PART INCLUDES:  
 1- EXTENDED STRAIN RELIEF BAR  
 MATL: STEEL BAR STOCK  
 1- #12-24 SCREW KIT (INCLUDES 4 SCREWS)

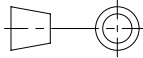

PART NUMBER		SRB19D7BL		
TITLE		MULTI-DEPTH STRAIN RELIEF BAR		
		CUSTOMER DRAWING		
ITEM REVISION NAME		M03137AF/06		
DATASET FILE NAME		M03137AF_DC/06A		
 THIRD ANGLE PROJECTION				
MATERIAL		SEE NOTE 4		DRAWING NUMBER
				03137-12
REV	DATE	BY	CHK	APR
06A	4-25-22	BJN	MDJR	MMR
UPDATED NOTES 1-2. NOTE 4: REMVD M6 SCREW KIT REVISED & REDRAWN PREVIOUS REVISIONS REMVD FOR CLARITY				
DESCRIPTION				ECN
				03137-12
DRAWN BY	DATE	CHK	SCALE	SIZE
BJN	2-22-11		NONE	A
SHEET 1 OF 1				

A-SIZE CUSTOMER

2

1

2

1