

THIS COPY IS PROVIDED ON A RESTRICTED BASIS AND IS NOT TO BE USED IN ANY WAY DETRIMENTAL TO THE INTERESTS OF PANDUIT CORP.

NOTES:

1. VISIT OUR ON-LINE CATALOG AT WWW.PANDUIT.COM FOR A LIST OF CURRENT PARTS APPLICABLE FOR USE WITH THIS PRODUCT.
2. BLUE COLOR WIRE CAP ASSEMBLY DESIGNATES TIA CATEGORY 6A (ISO 11801 CLASS EA) PERFORMANCE.
3. COLOR OF JACK MODULE IS INDICATED BY ** IN THE PART NUMBER (EXAMPLE: CJLR6X88TGBU FOR BLUE JACK). SEE WWW.PANDUIT.COM FOR AVAILABLE COLOR CODES.
4. PART NUMBERS OF AVAILABLE PACKAGE TYPES ARE SHOWN IN TABLE 1.
5. TERMINATION TOOL TO BE USED IS TGSJT. SOME PACKAGE TYPES INCLUDE A TERMINATION TOOL, SEE TABLE 1 FOR DETAILS.
6. ALL TX6A™ 10GIG™ CATEGORY 6A, 8 POSITION, 8 WIRE CONNECTOR MODULES ARE UNIVERSAL IN DESIGN. THEY ACCEPT ACCCEPT SIX AND EIGHT POSITION MODULAR PLUGS WITHOUT DAMAGE.
7. TERMINATES 22-26AWG SOLID OR STRANDED UTP CABLE LEFT AND RIGHT HORIZONALLY.
8. SEE INSTALLATION INSTRUCTION FOR PROPER TERMINATION METHOD.
9. WIRE CAP LABEL WHICH IS PART OF THE WIRE CAP ASSEMBLY IS CODED FOR T568B WIRING SCHEME.
10. PART INCLUDES:
MODULE HOUSING: POLYCARBONATE W/ UL94V-0 FLAME RATING.
WIRE CAP ASSEMBLY: POLYCARBONATE W/ UL94V-0 FLAME RATING.
11. WEIGHT: 1.53 LBS/100 PCS (695 g/100 PCS).
12. DIMENSIONS IN () ARE METRIC.
13. ALL MATERIALS AND COMPONENTS USED MEET THE LATEST RoHS REQUIREMENTS.

45° LEFT/RIGHT UTP WIRE CAP

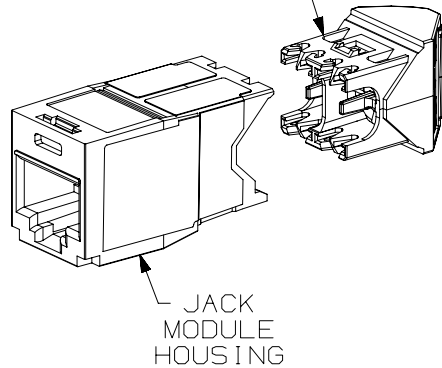

JACK MODULE HOUSING

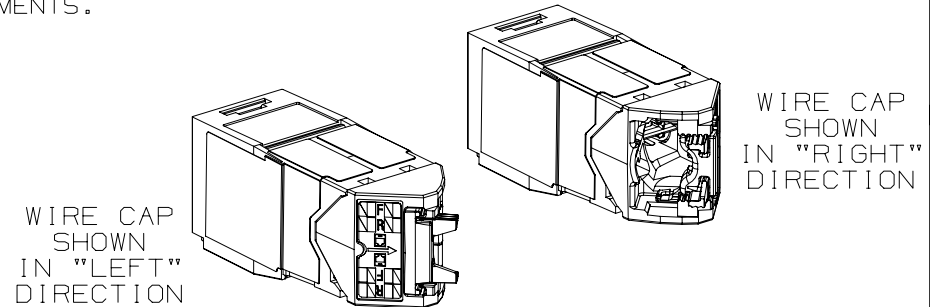
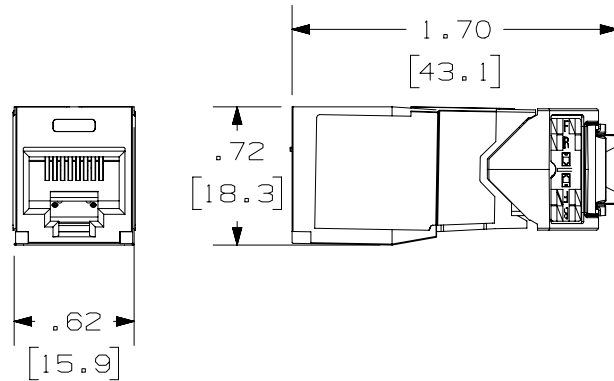

TABLE 1: PACKAGE TYPE AND TERMINATION TOOL

| PART NUMBER | PACKAGED QUANTITY | TERMINATION TOOL: TGSJT |
|-----------------|------------------------------------|-------------------------------------|
| CJLR6X88TG** | INDIVIDUAL PACKAGED, 50 PER CARTON | INCLUDED (1 PER CARTON OF 50 PARTS) |
| CJLR6X88TG**-24 | BULK PACKAGED, 24 PER BOX | INCLUDED (1 PER BOX OF 24 PARTS) |

| | | | |
|--|--|-------------------|------|
| PART NUMBER | | SEE TABLE 1 | |
| TITLE | | | |
| TX6A™ 10GIG™ CATEGORY 6A JACK MODULE WITH LEFT/RIGHT WIRE CAP ASSEMBLY | | | |
| CUSTOMER DRAWING | | | |
| ITEM REVISION NAME | | 00075SAX/01 | |
| DATASET FILE NAME | | 00075SAX_DC01/01A | |
| MATERIAL | | SEE NOTE 10 | |
| DRAWING NUMBER | | 00075SAX-01 | |
| DRAWN BY | | DATE | CHK |
| BJN | | 11-12-19 | ROJC |
| SCALE | | FULL | |
| SHEET | | 1 OF 1 | |
| SIZE | | A | |

| REV | DATE | BY | CHK | APR | DESCRIPTION | ECN |
|-----|----------|------|------|------|------------------------|-------------|
| 01A | 12-15-21 | MDJR | ROJC | TMBA | UPDATED PACKAGING | 00075SAX-01 |
| 00A | 11-12-19 | BJN | ROJC | TMBA | RELEASED TO PRODUCTION | M09000KV |