

NOTE: Some views in this document may vary slightly from your actual cabinet configuration. Components missing from some views for clarity purposes.

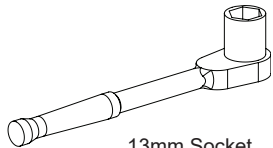

13mm Socket Wrench

15mm Socket Wrench

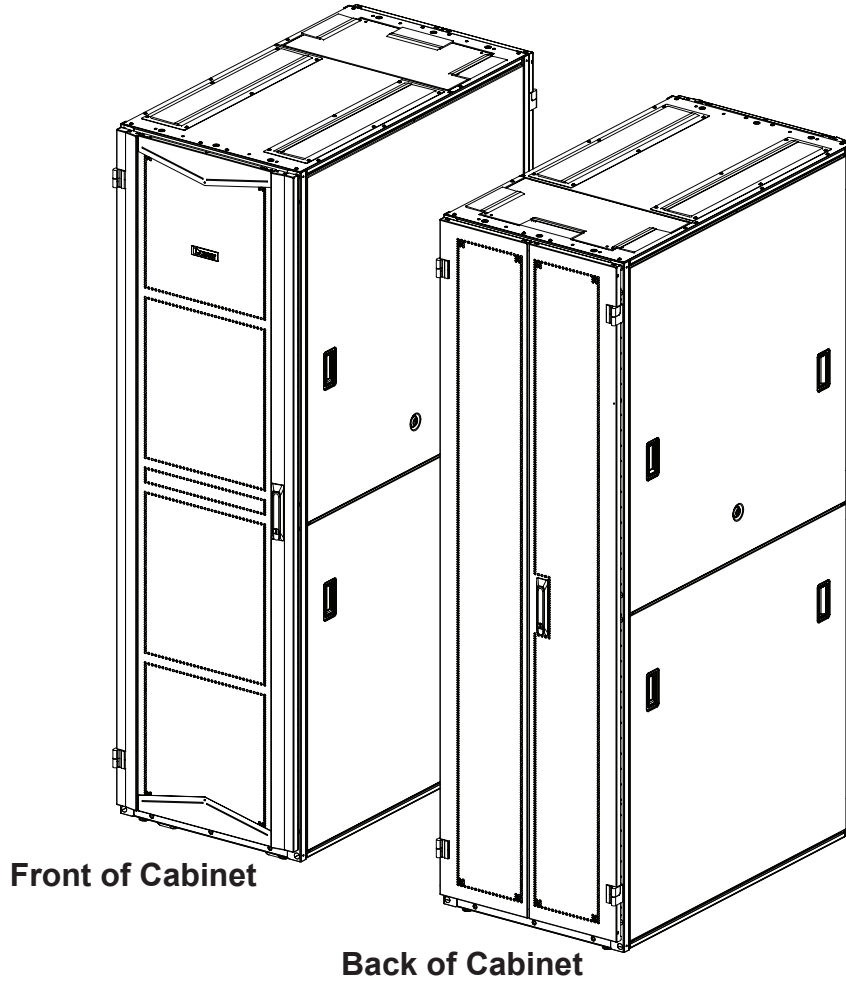

6mm Hex Key



T25 Torx driver

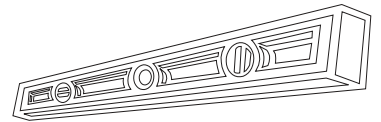

122mm (48") Level

FlexFusion Cabinets Tool List

Disclaimer:

The information contained in this manual is intended as a guide for use by persons having technical skill at their own discretion and risk. The recommended practices are based on average conditions. Panduit makes no representation or warranty, express or implied, nor assumes any responsibility for the accuracy or completeness of these installation instructions. Panduit does not guarantee any favorable results nor assume any liability for damages, improper installation, system failures, or any other problems that could arise in connection with the use of these installation instructions.

For Technical Support: www.panduit.com/resources/install_maintain.asp

IMPORTANT SAFETY INFORMATION



WARNING

CABINET TIPPING HAZARD

This cabinet can easily be tipped. Use extreme caution when unpacking or moving the cabinet.

Use **at least [2] persons** to remove cabinet from pallet and move cabinet into position (refer to page 5).

After the cabinet has been removed from the pallet, ensure that the leveling legs are in the fully-retracted position (refer to pages 5-6) before rolling the cabinet on casters. It is recommended to add at least 136Kg (300 lbs.) of equipment to the bottom 10RU of the cabinet to provide extra stability before rolling the cabinet.

When rolling the cabinet on casters, push the cabinet from the front or rear only, to prevent the cabinet from tipping on its side.

When rolling the cabinet on its casters, gaps in the floor, including elevator thresholds, should be covered with a rigid plate capable of bearing the cabinet's load

FAILURE TO FOLLOW THESE INSTRUCTIONS CAN LEAD TO SERIOUS INJURY, DEATH, OR DAMAGE TO YOUR EQUIPMENT.

Safety Notes:

The maximum static weight load of the cabinet is 1588 kg (3500lbs.) The maximum weight load when the cabinet is rolling on casters is 1134 kg (2500 lbs.) The weight load should be evenly distributed across the height of the cabinet, with the heaviest components mounted at the bottom of the cabinet.

The maximum operating temperature is 50° C; so that the installer is able to determine acceptability of use of accessories and components in the operating state.

The equipment shall be installed or serviced by trained service personnel in accordance with the applicable requirements of the National Electric Code, ANSI/NFPA 70 or Canadian Electrical Code and the applicable sections of ANSI C2, the National Electrical Safety Code. These instructions shall not result in the risk of fire, electric shock, or injury to persons.

UL Listing covers enclosure cabinet only

For Technical Support: www.panduit.com/resources/install_maintain.asp

Table of Contents

Packaging Material Removal 4

Leveling 5

Floor Mounting 6

Ganging Multiple Cabinets Together 7

Grounding 8

Integral Grounding 8

Equipment Rail Spacing Adjustment..... 9

Toolless Equipment Rail Spacing Adjustment 10

Top Cap 11

Top Cap - Top Cap Hatch Door..... 12

Cable Management Fingers..... 13

Cable Management Fingers Locations..... 14

Single Hinge Door (Removal and Installation)..... 15

Split Doors (Removal and Installation)..... 16

Side Panels Removal..... 17

Side Panels (Removal and Installation)..... 18

PDU Bracket Adjustment (Removal and Installation)..... 19

Vertical Cable Management Panel (VCMP) (Removal and Installation) 20

Vertical Cable Management Panel KEEP-OUT Areas for Side Panel Interference..... 21

Packaging Material Removal

- Remove all stretch wrap, protective cardboard, and plastic bag from outside of cabinet.
- Remove [4] Hold Down Brackets at front and rear of cabinet.
- Use **at least [2] persons** to carefully remove cabinet from pallet.

Note:

Shipping Hold Down Bracket doubles as **Floor Mounting Bracket**. Retain bracket for floor mounting. (see Page 6)

Important:

Leveling Legs must be fully retracted before the cabinet is moved into place. Sliding cabinet on leveling legs may result in damage to the leveling legs. (Leveling Legs ship in retracted position)

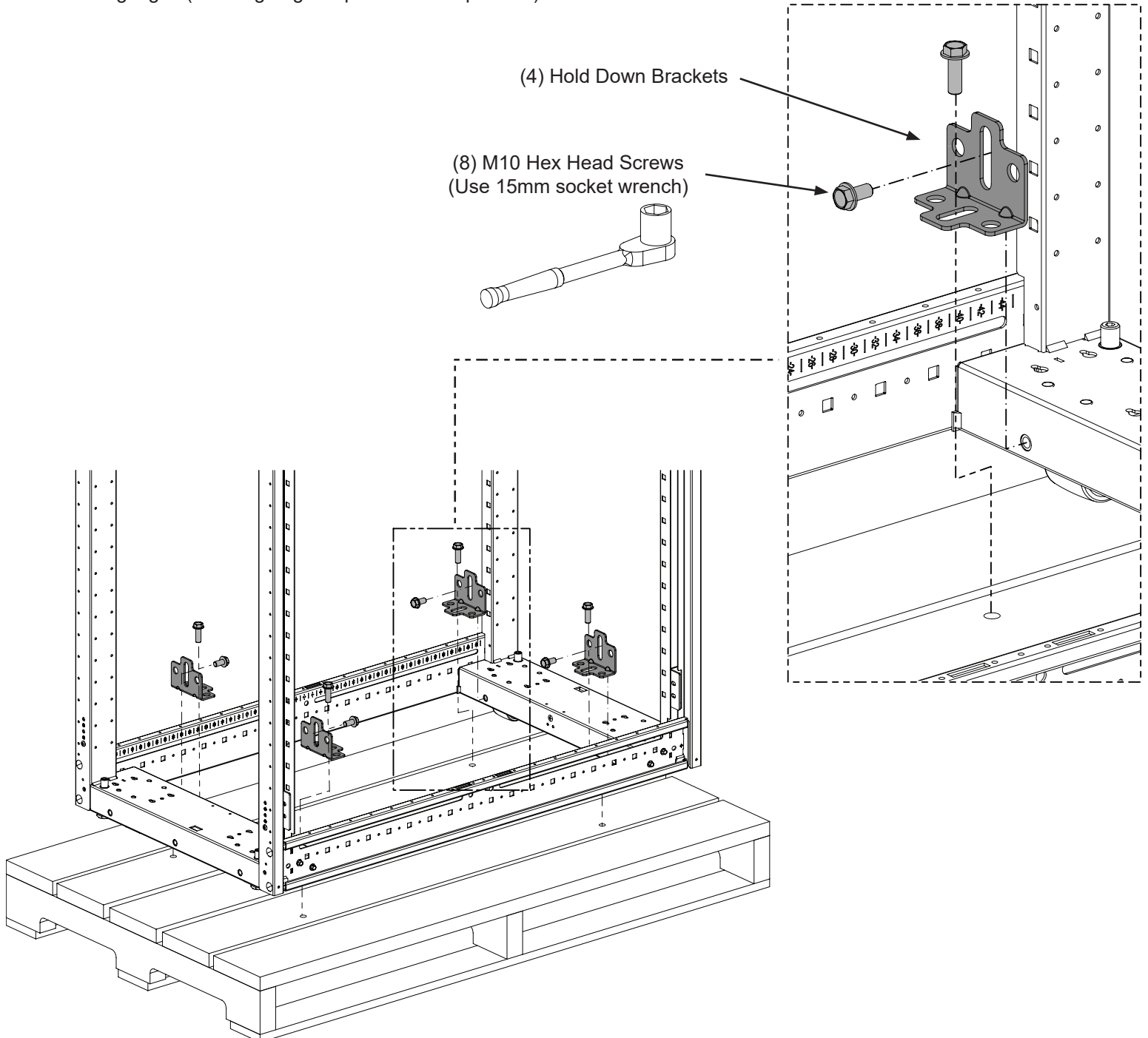

Leveling

- Ensure that (4) Leveling Legs are fully retracted.
- Move Cabinet into final position.
- Lower the (4) Leveling Legs until the cabinet weight is fully supported by only the leveling legs.
- Adjust the (4) Leveling Legs so that the cabinet is level front-to-back and side-to-side.

1

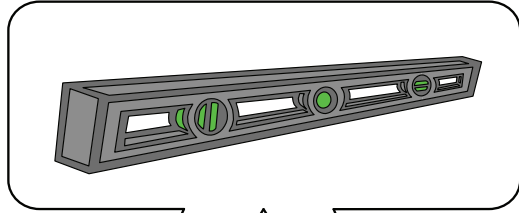

6mm Hex Key
4 places
Level Front to Back

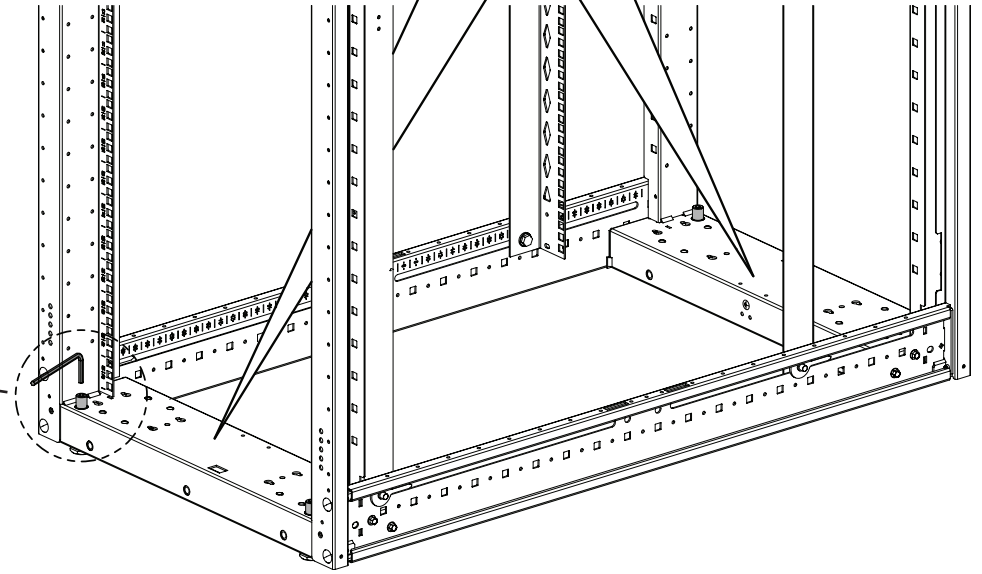
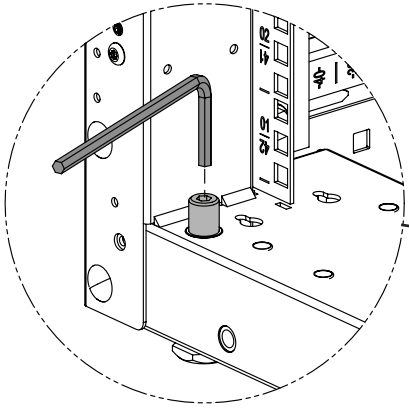

2

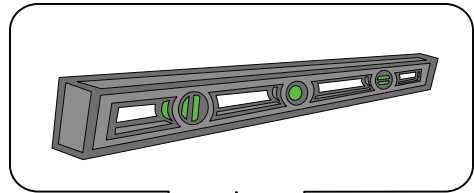

6mm Hex Key
4 places
Level Side to Side

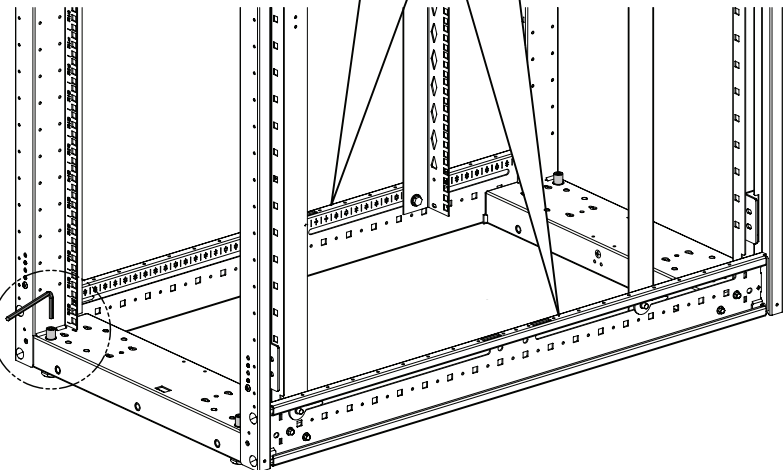
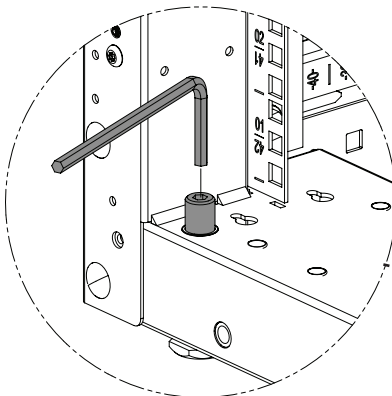



WARNING

Cabinet Tipping Hazard

Mount cabinet to floor before equipment is installed in cabinet.

FAILURE TO FOLLOW THESE INSTRUCTIONS CAN LEAD TO SERIOUS INJURY, DEATH, OR DAMAGE TO YOUR EQUIPMENT.

Floor Mounting

- Secure (2) **Shipping Hold Down Brackets** at front and rear of cabinet
- See Floor Mounting View below for floor mounting dimensions
- Attach the anchors to the floor with appropriate hardware for your type of floor

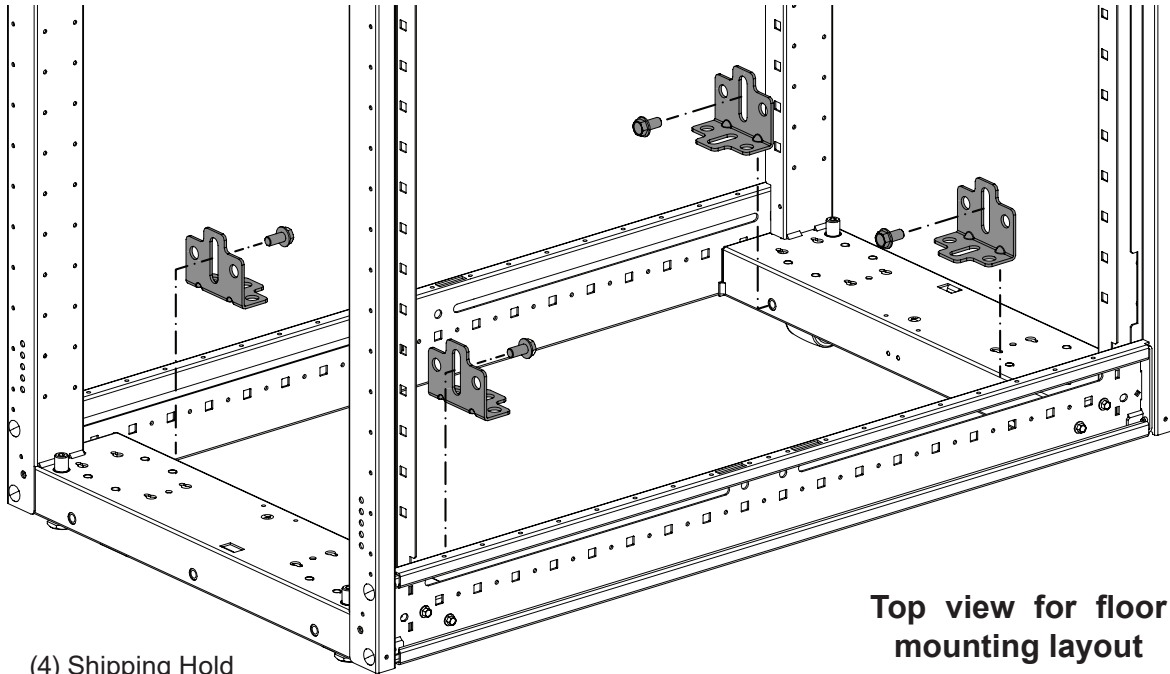

(4) Shipping Hold Down Brackets & M10 screws
Previously removed during 'Packaging Material Removal' step (Page 4).

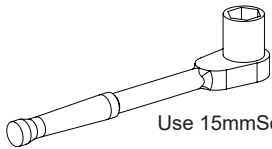

Use 15mm Socket Wrench

DIM A:

- 600mm wide cabinets: 390mm (15.4")
- 700mm wide cabinets: 490mm (19.3")
- 800mm wide cabinets: 590mm (23.2")

DIM B:

- 1070mm deep cabinets: 744mm (29.3")
- 1200mm deep cabinets: 894mm (35.2")

Top view for floor mounting layout

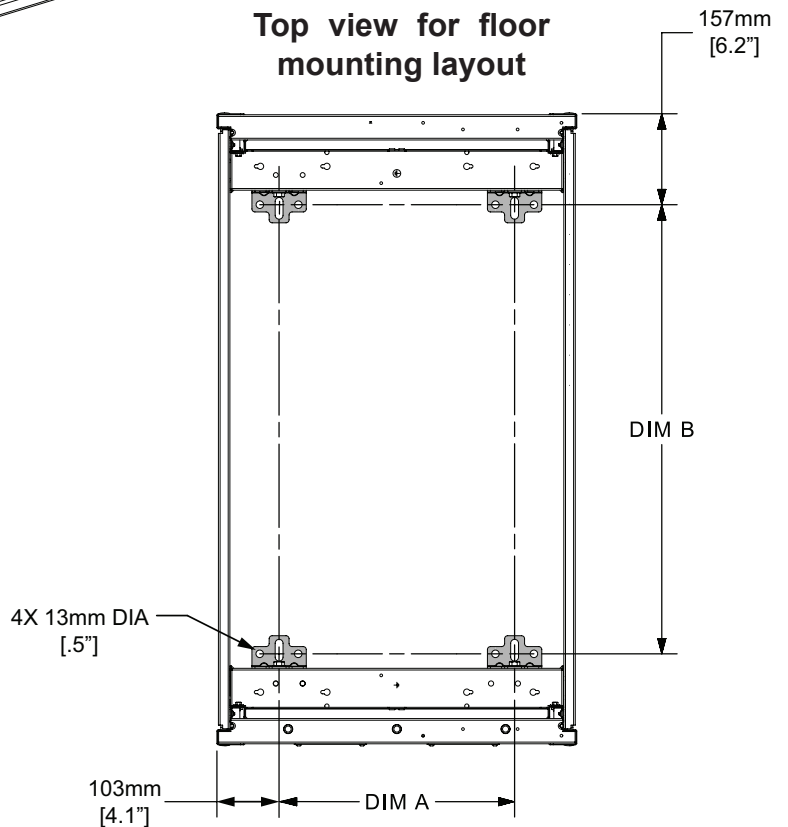



WARNING

Cabinet Tipping Hazard

Ganging of cabinets only provides limited stability to the cabinets, and is not a substitute for proper leveling or floor mounting of cabinets. Ensure that cabinets are properly mounted to floor before cabinet is fully loaded with equipment. (See page 6)

FAILURE TO FOLLOW THESE INSTRUCTIONS CAN LEAD TO SERIOUS INJURY, DEATH, OR DAMAGE TO YOUR EQUIPMENT.

Ganging Multiple Cabinets Together

- Ensure cabinets are level
- Secure Ganging Brackets to cabinets at (2) front locations and (2) back locations
- Use Ganging Brackets to cinch cabinets together

IMPORTANT:

Ensure cabinets are level by following the guidelines on page 6. Leveling the cabinet prior to ganging is important to ensure proper door operation.

1

(4) Ganging Bracket
per dual ganged cabinets

(2) M5 Screws
per Ganging Bracket



Use T25 Torx driver

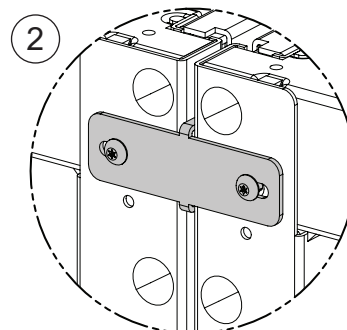
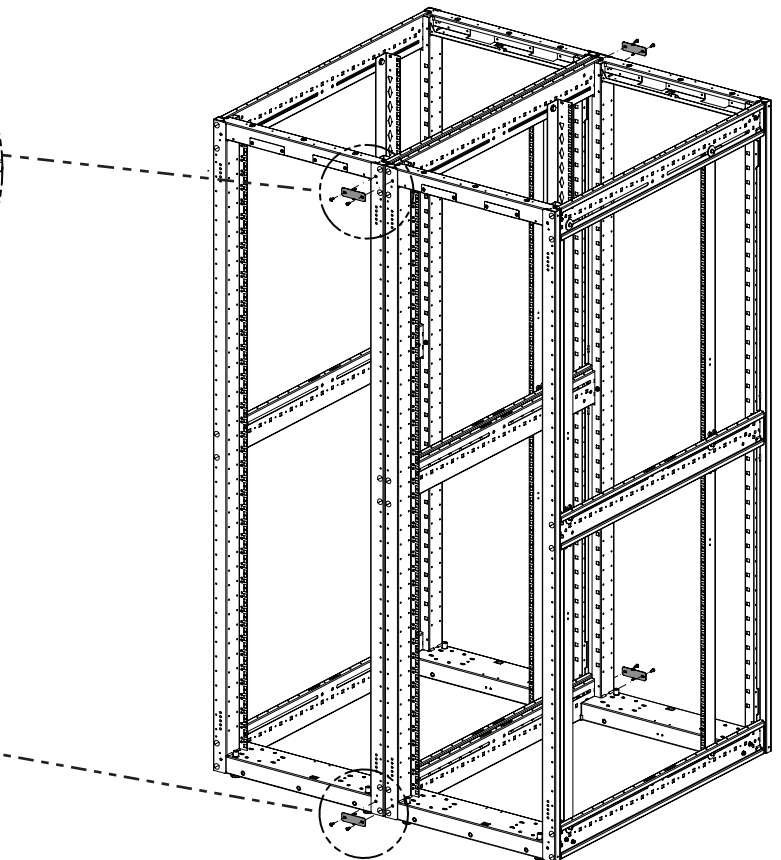
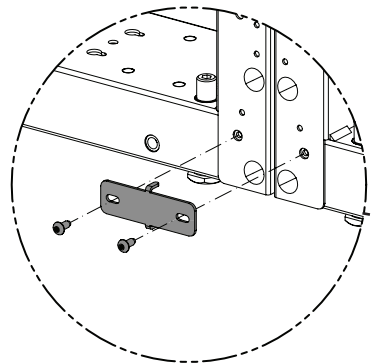
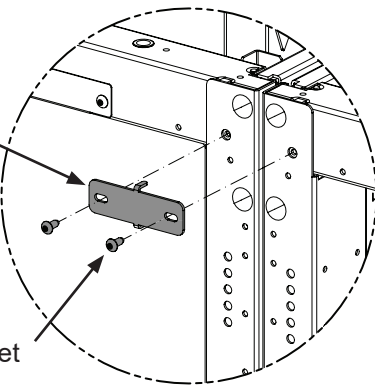

⚠ DANGER

Electrical Shock Hazard

Each cabinet must be connected to the Common Bonding Network (CBN).

FAILURE TO FOLLOW THESE INSTRUCTIONS CAN LEAD TO SERIOUS INJURY, DEATH, OR DAMAGE TO YOUR EQUIPMENT.

Grounding

- Attach Grounding Lug or Grounding Bar to Common Bonding Network (CBN), at any of the (4) locations shown below
- Grounding location is indicated by universal ground symbol near grounding lug locations.
- Remove factory-installed masking tape at grounding lug location to expose unpainted surface of cabinet frame. Grounding lug or grounding bar must be assembled onto this unpainted surface (*per NEC NFPA 70 Article 250.12*).
- Use (2) M5 x 12mm thread forming bonding screws to fasten grounding terminal to cabinet frame (torque screws to 5.1 N-m (45 in-lb))

(2) Top Grounding Locations

Front and rear of cabinet
Remove masking tape

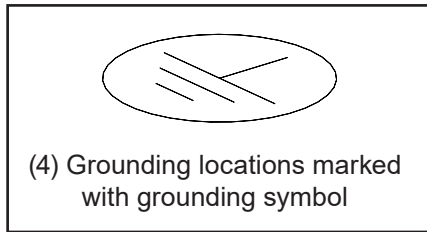

(2) Bottom Grounding Locations

Front and rear of cabinet
Remove masking tape

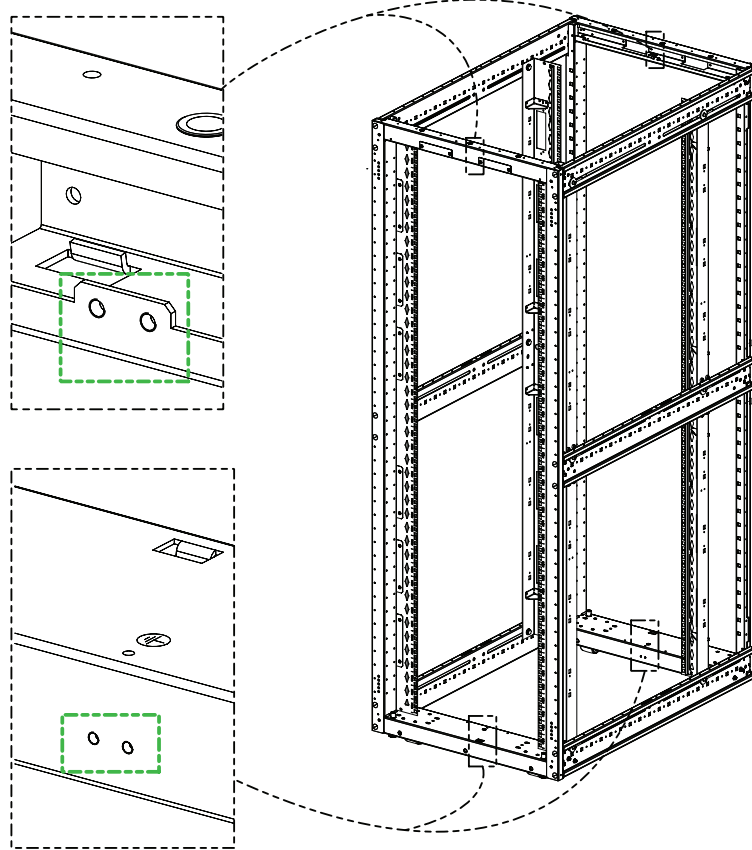

Integral Grounding

- Spring Clip - No grounding wires needed for Doors, SidePanels, or Top Cap components

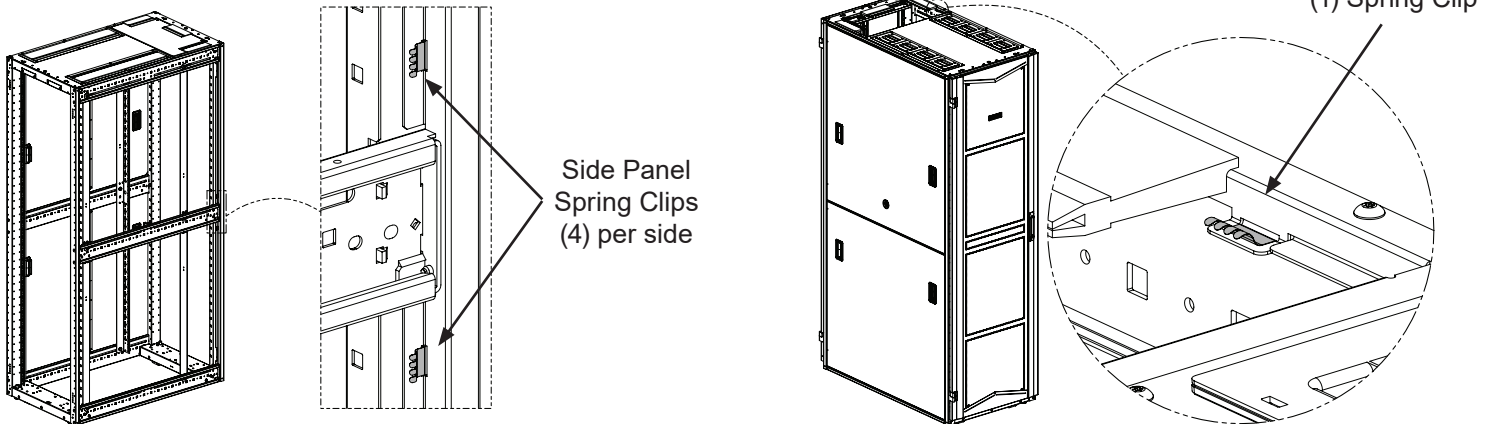

For Technical Support: www.panduit.com/resources/install_maintain.asp



WARNING

Falling Equipment Hazard

Remove all equipment installed onto equipment rails before performing any adjustments to equipment rail spacing.

FAILURE TO FOLLOW THESE INSTRUCTIONS CAN LEAD TO SERIOUS INJURY, DEATH, OR DAMAGE TO YOUR EQUIPMENT.

Equipment Rail Spacing Adjustment - Standard Hardware type

- Loosen, but **DO NOT REMOVE** (3) M8 Hex Head Bolts at top, bottom, & center of each Equipment Rail
- Adjust Equipment Rail to desired position
- Use level to ensure the E-Rails remain level in thier new position
- Re-tighten M8 Hex Head Bolts to **35.6N·m ± 3.5N·m [26.3 ± 2.6 ft-lbs]**

600mm Wide Cabinet shown

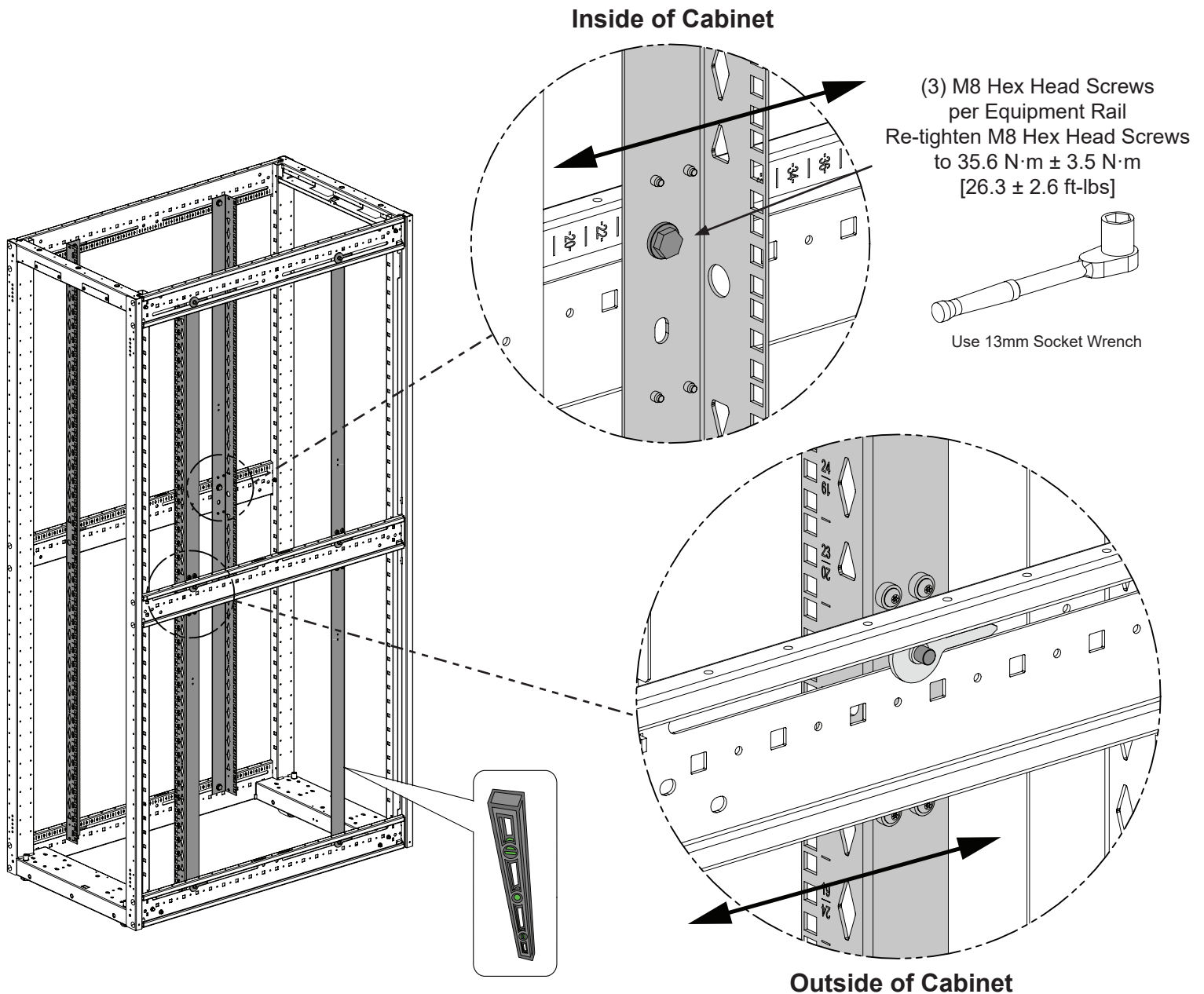



WARNING

Falling Equipment Hazard

Remove all equipment installed onto equipment rails before performing any adjustments to equipment rail spacing.

FAILURE TO FOLLOW THESE INSTRUCTIONS CAN LEAD TO SERIOUS INJURY, DEATH, OR DAMAGE TO YOUR EQUIPMENT.

Equipment Rail Spacing Adjustment - Tool-less type (optional)

- Rotate the handles in towards the inside of cabinet at top, bottom, & center of each Equipment Rail
- Adjust Equipment Rail to desired position
- Use level to ensure the E-Rails remain level in their new position
- **Re-tighten ALL handles** by firmly rotating all the way back to original position

600mm Wide Cabinet shown

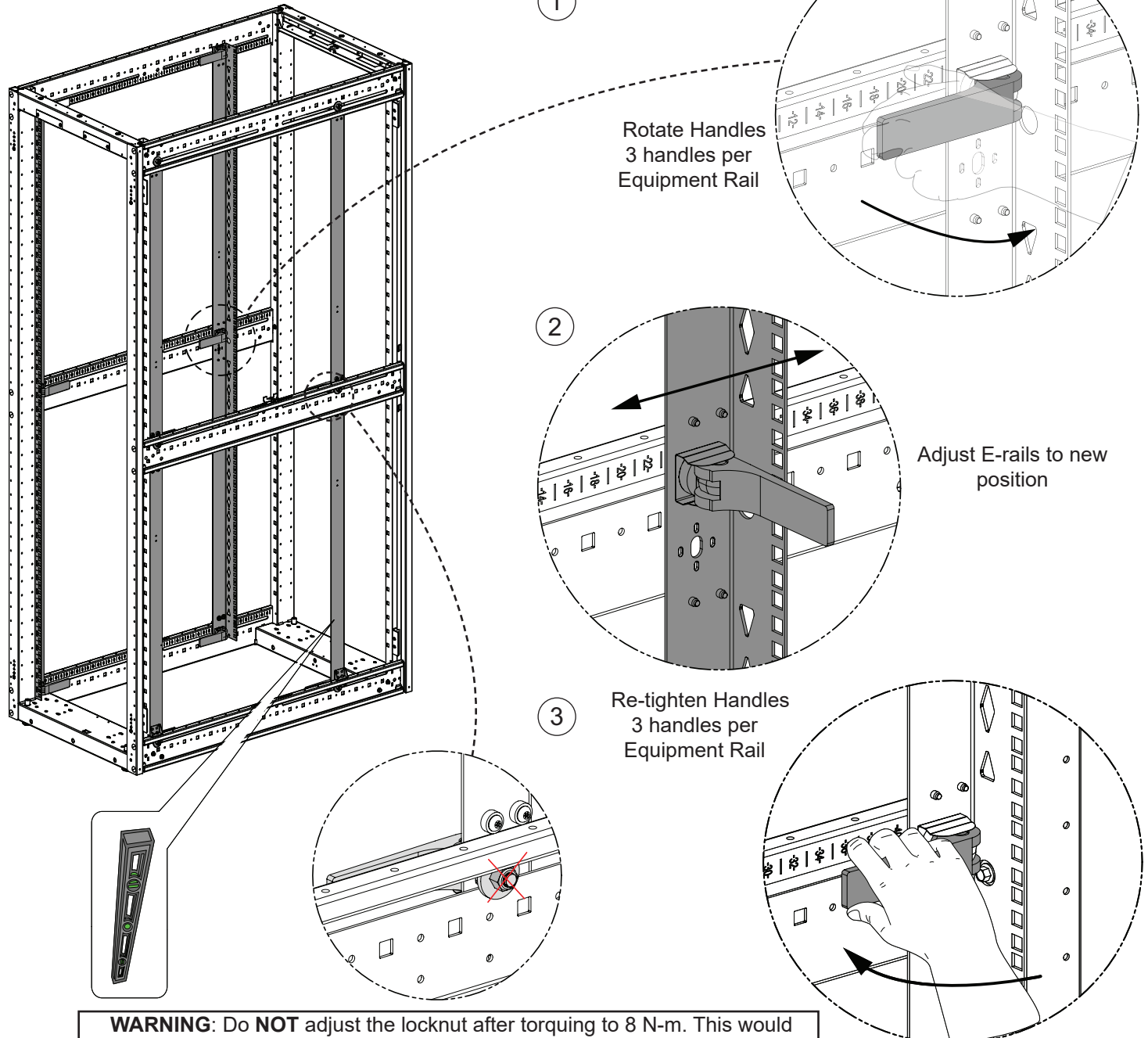

WARNING: Do **NOT** adjust the locknut after torquing to 8 N-m. This would affect toolless mechanism reliability or functionality. If locknut is accidentally adjusted, re-torque it again until residual torque 8 N-m is achieved.

For Technical Support: www.panduit.com/resources/install_maintain.asp

Top Cap

- **Brush Seal option** - Left & right pass-thru openings with brush seals.
- **Bezel & Cover option** - Bezel & Cover openings can be used with Panduit Cool Boot **CTGN3X5** to seal around cables to prevent hot air recirculation.

600mm Wide Cabinet shown

Brush Seal option

1070 deep cabinets have (2) 87mm [3.4"] x 600mm [23.6"] openings
 1200 deep cabinets have (2) 87mm [3.4"] x 750mm [29.5"] openings

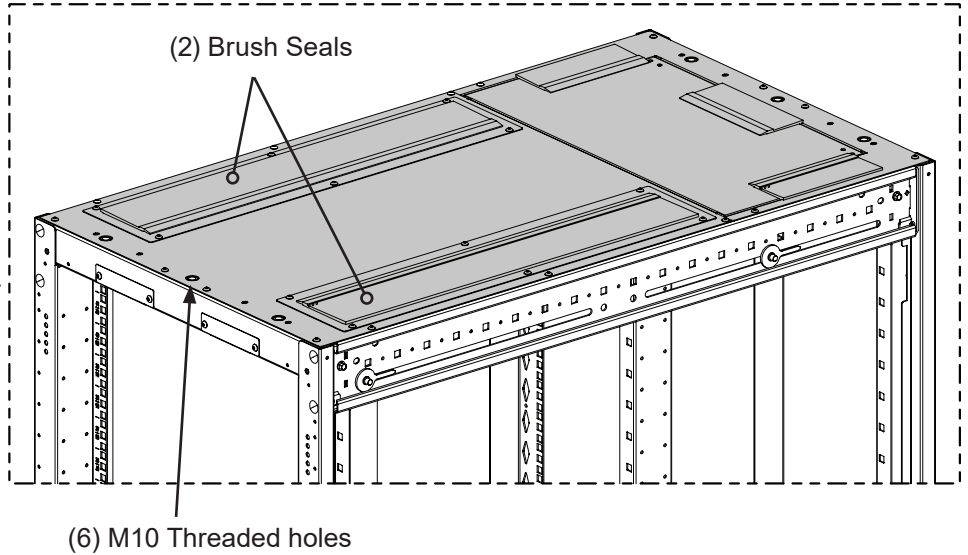
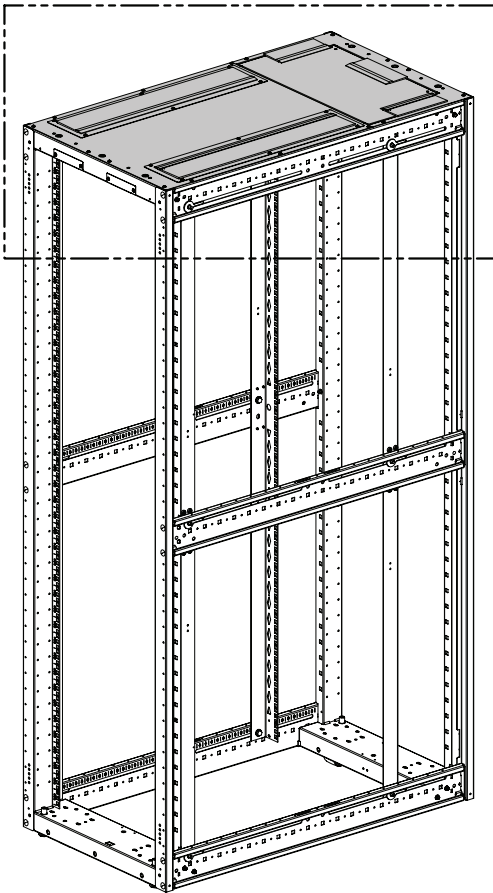

Bezel & Cover option

Covers can be removed to allow for overhead cable entry
 1070 deep cabinets have (8) 83mm [3.3"] x 120mm [4.7"] openings
 1200 deep cabinets have (10) 83mm [3.4"] x 120mm [4.7"] openings

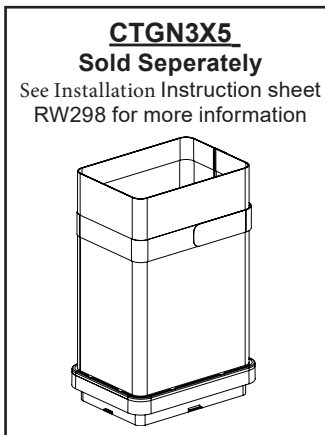
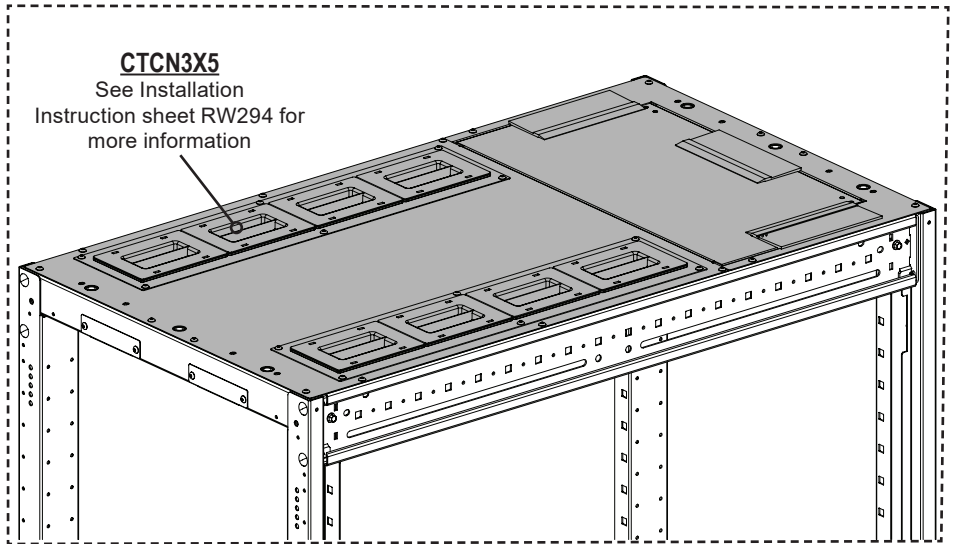

Top Cap - Top Cap Hatch Door

- Top Cap Hatched Door has (2) spring loaded pins that can be released in order to open door.
- Top Cap Hatch Door contains (3) Brush Seal openings.
- Door can be swung open and/or removed.
- Hatch can be opened for installing PDU receptacle or larger devices

600mm Wide Cabinet shown

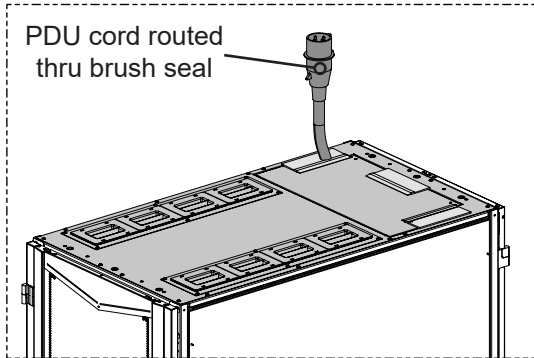
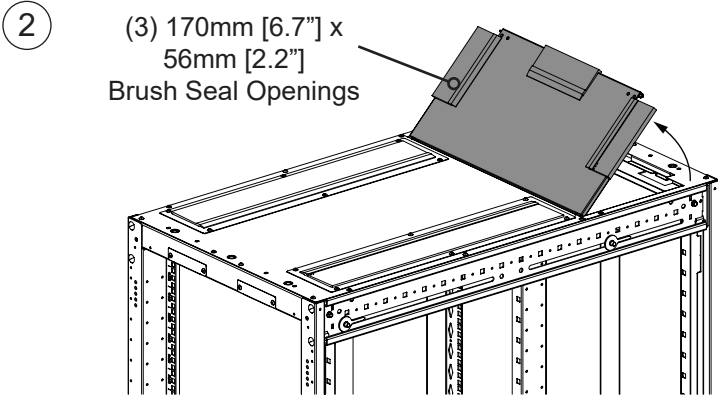
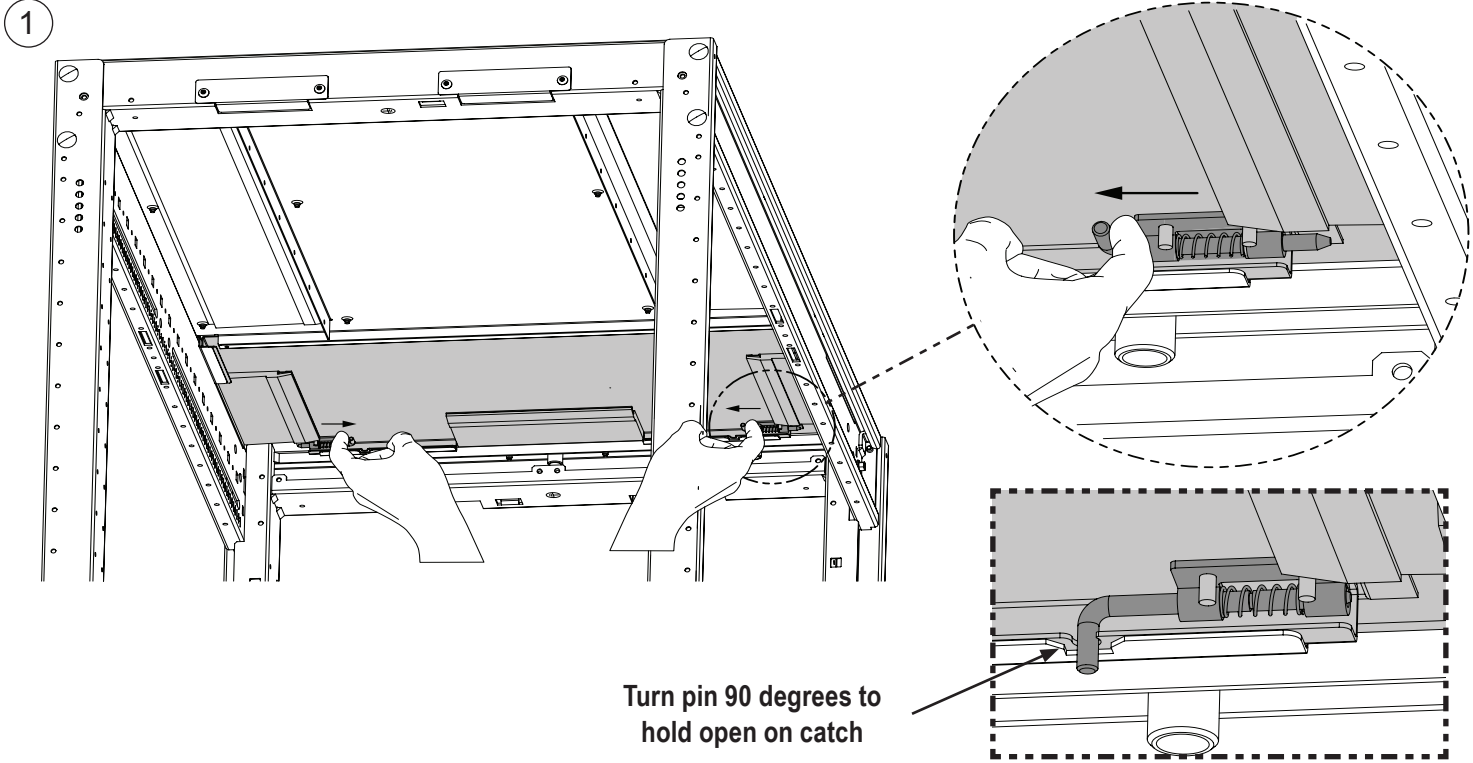

Top Cap Hatch Opening

600mm wide - 284mm [11.2"] x 548mm [23.0"]

700mm wide - 284mm [11.2"] x 648mm [25.5"]

800mm wide - 284mm [11.2"] x 748mm [29.5"]

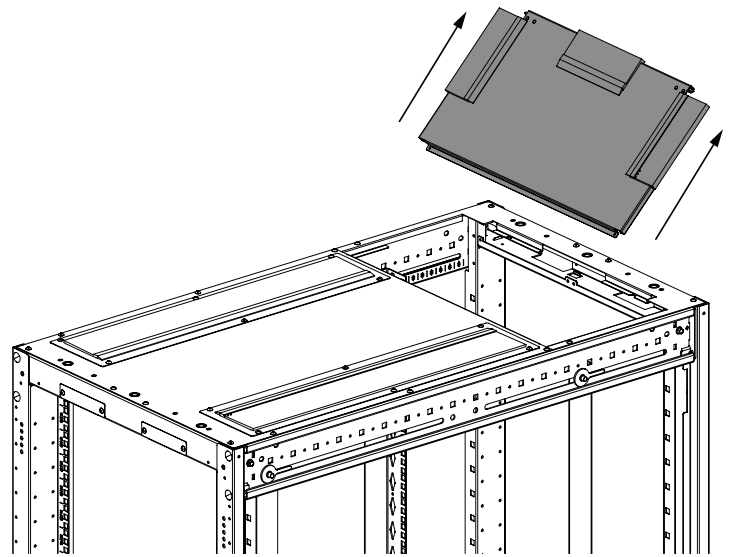

For Technical Support: www.panduit.com/resources/install_maintain.asp

Cable Management Fingers

- Push tabs of the Cable Management Fingers into diamond patterns of Cabinet E-rails.
- Then push tabs of the Cable Management Fingers down to lock in place.

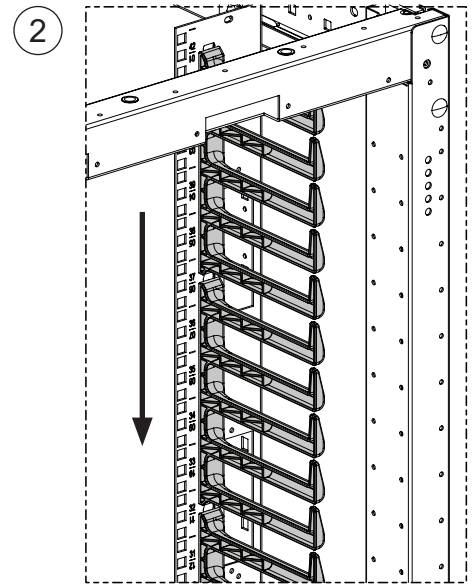
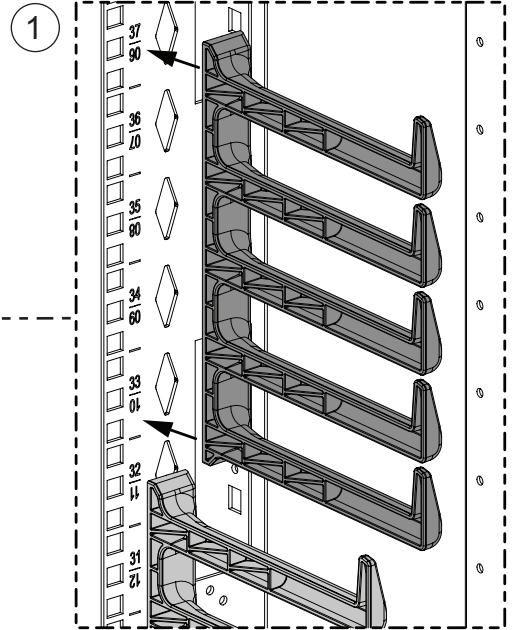
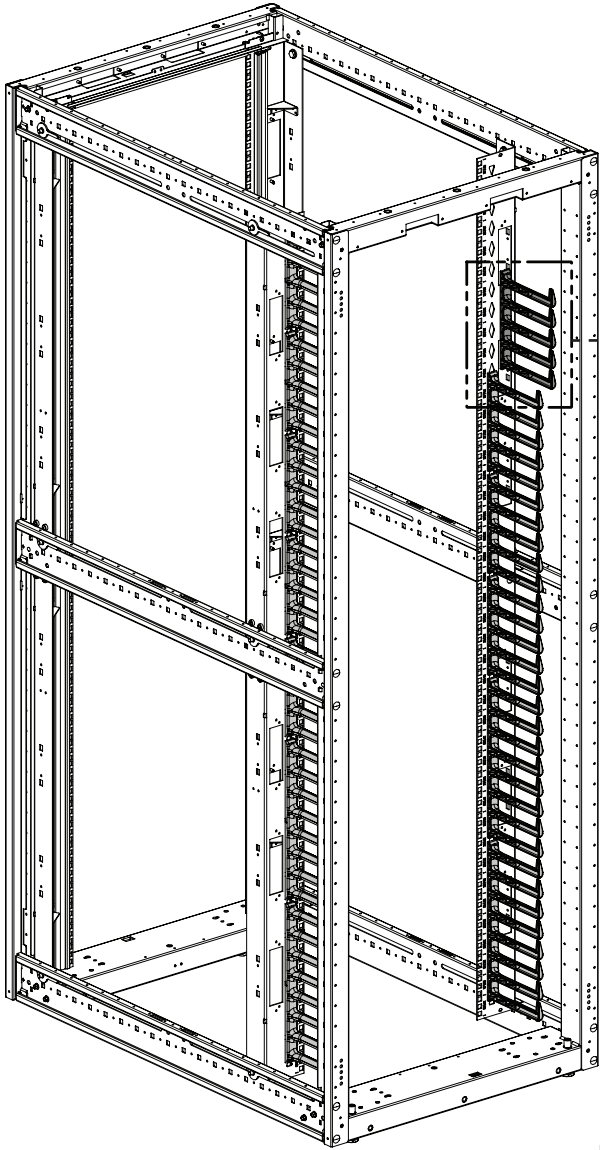

BACKSIDE VIEW

Note: The radius on fingers must face towards the outside of cabinet

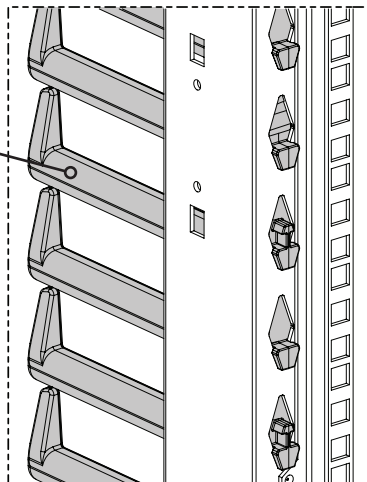

Cable Management Fingers Locations

- Follow locations shown below to install Finger Kits

600 Wide Cabinets

600mm x 42RU	
RU	Finger
33 - 41	8RU Finger
28 - 33	5RU Finger
23 - 28	5RU Finger
15 - 20	5RU Finger
10 - 15	5RU Finger
2 - 10	8RU Finger

600mm x 45RU	
RU	Finger
35 - 43	8RU Finger
30 - 35	5RU Finger
25 - 30	5RU Finger
16 - 21	5RU Finger
11 - 16	5RU Finger
3 - 11	8RU Finger

600mm x 48RU	
RU	Finger
39 - 47	8RU Finger
31 - 39	8RU Finger
26 - 31	5RU Finger
18 - 23	5RU Finger
10 - 18	8RU Finger
2 - 10	8RU Finger

600mm x 51RU/52RU	
RU	Finger
41 - 49	8RU Finger
33 - 41	8RU Finger
28 - 33	5RU Finger
19 - 24	5RU Finger
11 - 19	8RU Finger
3 - 11	8RU Finger

700 & 800 Wide Cabinets

700mm & 800mm x 42RU	
RU	Finger
37 - 42	5RU Finger
32 - 37	5RU Finger
27 - 32	5RU Finger
22 - 27	5RU Finger
17 - 22	5RU Finger
9 - 17	8RU Finger
1 - 9	8RU Finger

700mm & 800mm x 45RU	
RU	Finger
40 - 45	5RU Finger
35 - 40	5RU Finger
30 - 35	5RU Finger
25 - 30	5RU Finger
17 - 25	8RU Finger
9 - 17	8RU Finger
1 - 9	8RU Finger

700mm & 800mm x 48RU	
RU	Finger
43 - 48	5RU Finger
38 - 43	5RU Finger
33 - 38	5RU Finger
25 - 33	8RU Finger
17 - 25	8RU Finger
9 - 17	8RU Finger
1 - 9	8RU Finger

700mm & 800mm x 51RU/52RU	
RU	Finger
46 - 51	5RU Finger
41 - 46	5RU Finger
33 - 41	8RU Finger
25 - 33	8RU Finger
17 - 25	8RU Finger
9 - 17	8RU Finger
1 - 9	8RU Finger

Single Hinge Door (Removal and Installation)

- Open Door to approximately 90°.
- Lift Door off of hinges and pull away from Cabinet frame.
- **Reverse Steps** to install Single Hinge Door.

Note: Align Top pins first.

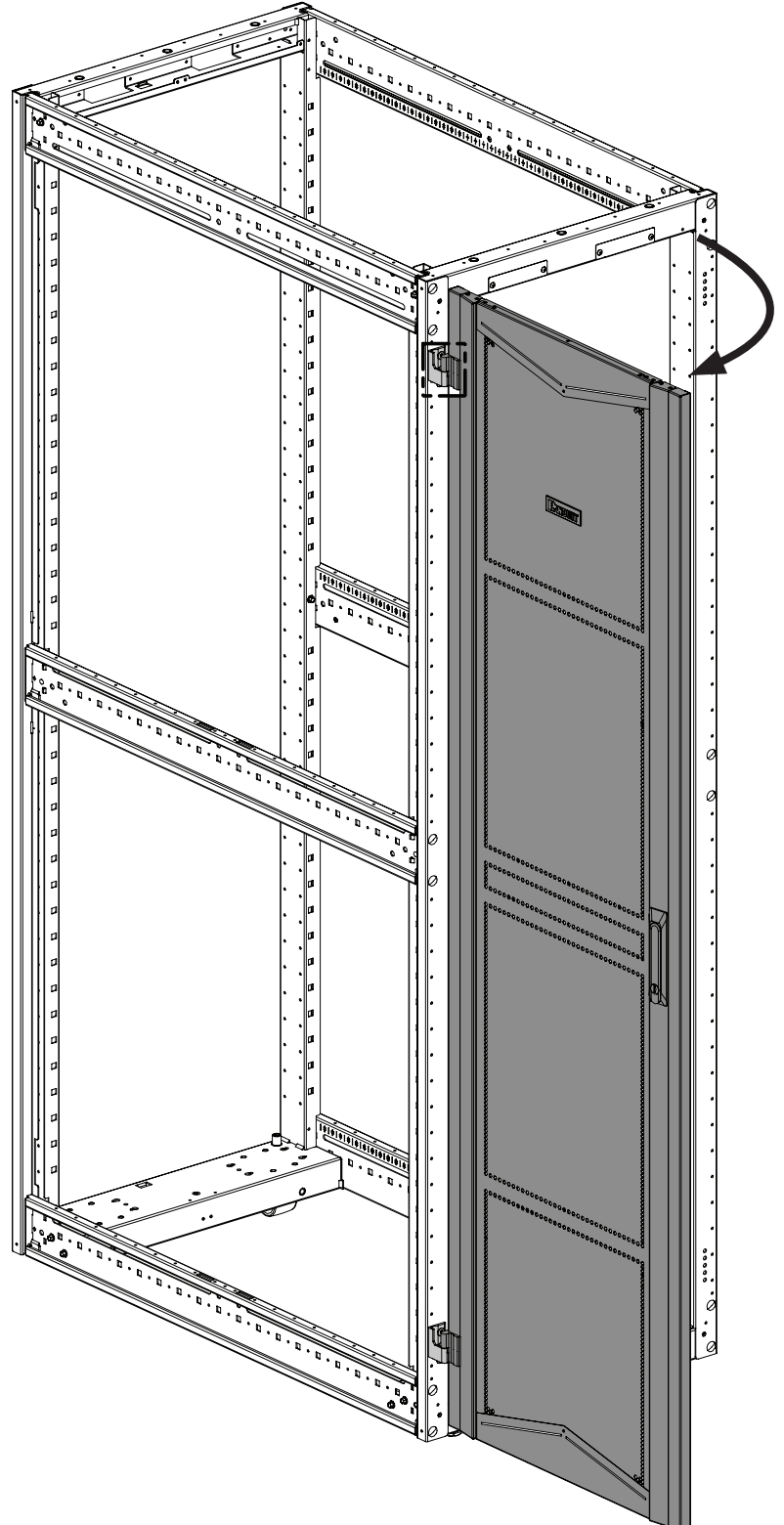
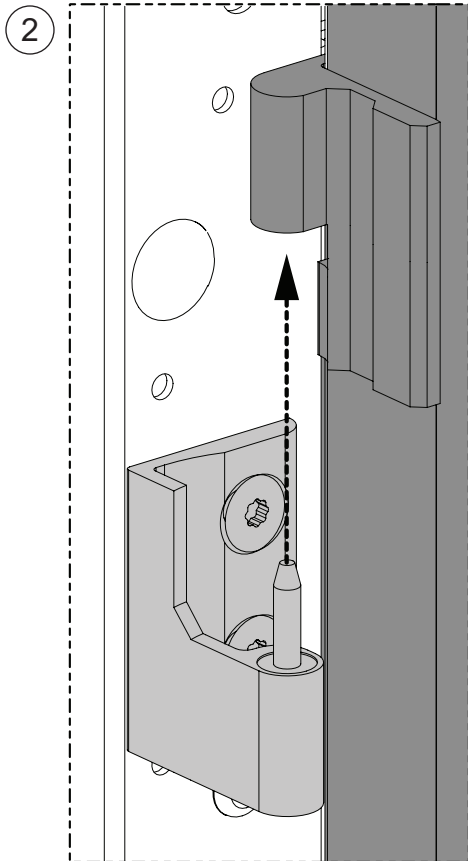
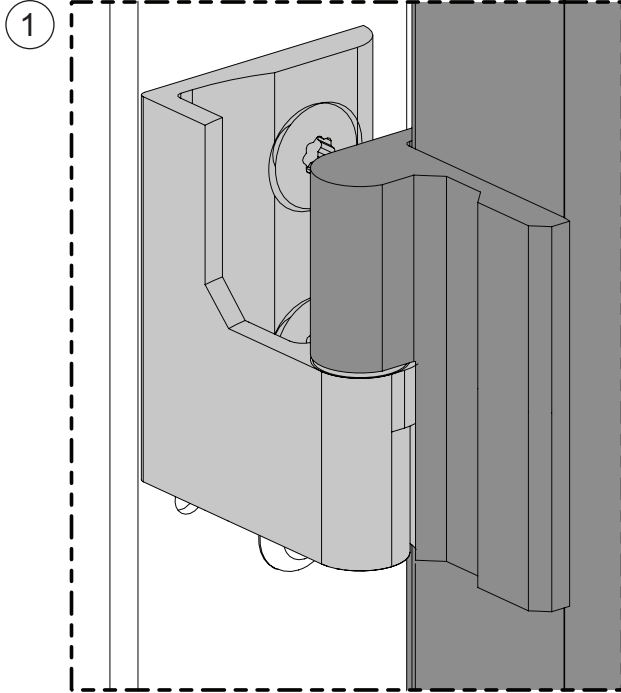

For Technical Support: www.panduit.com/resources/install_maintain.asp

Split Doors (Removal and Installation)

- Open Split Doors to approximately 90°.
- Lift Doors off of hinges and pull away from Cabinet frame.
- **Reverse Steps** to install Split Doors.

Note: Align Top pins first.

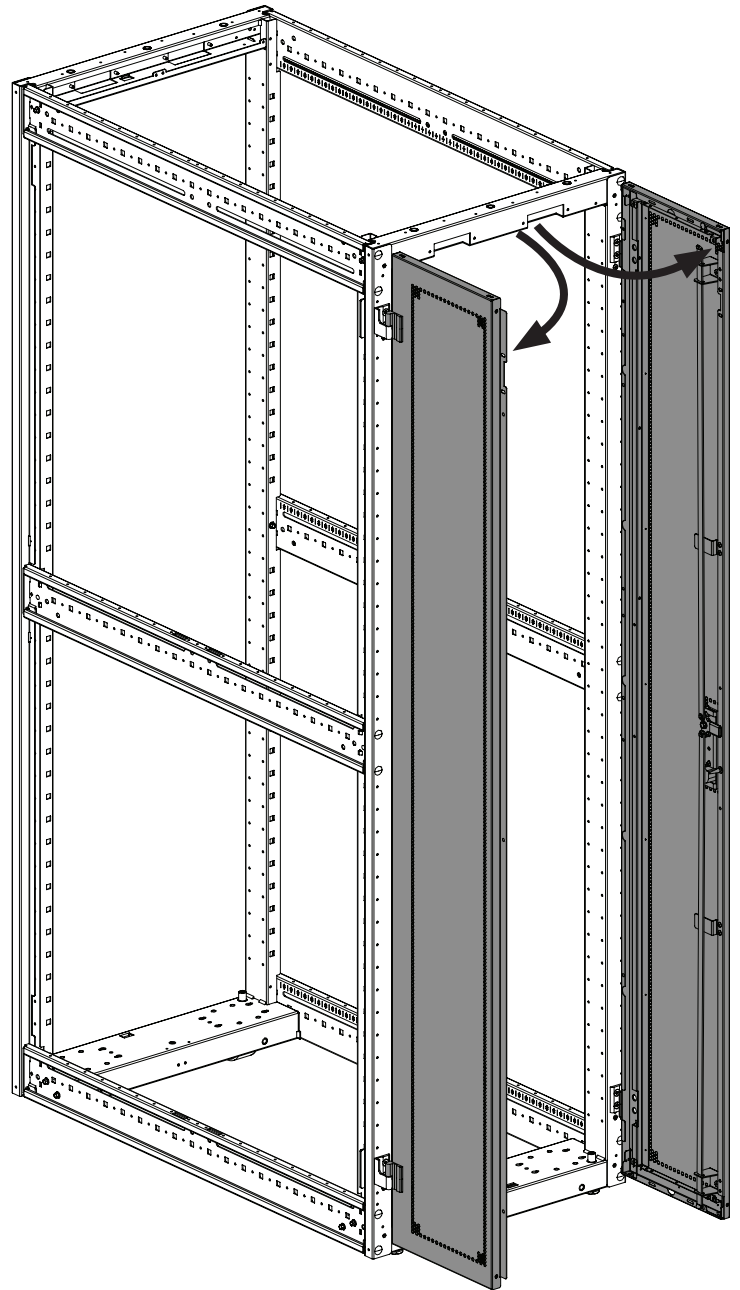
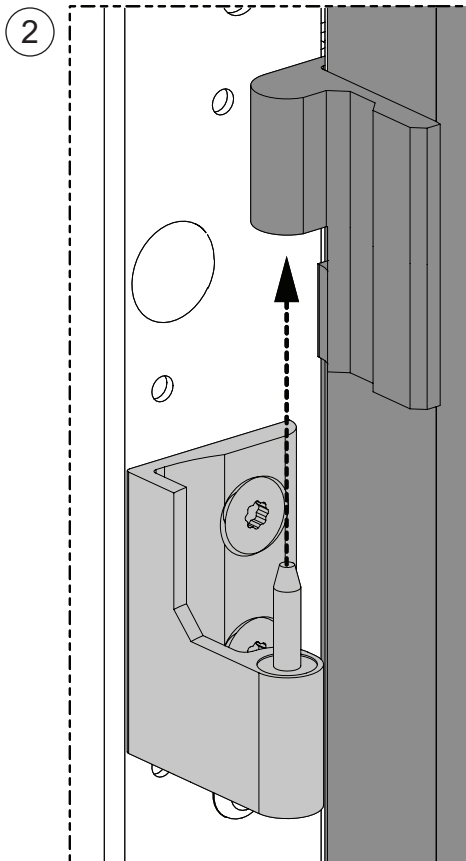
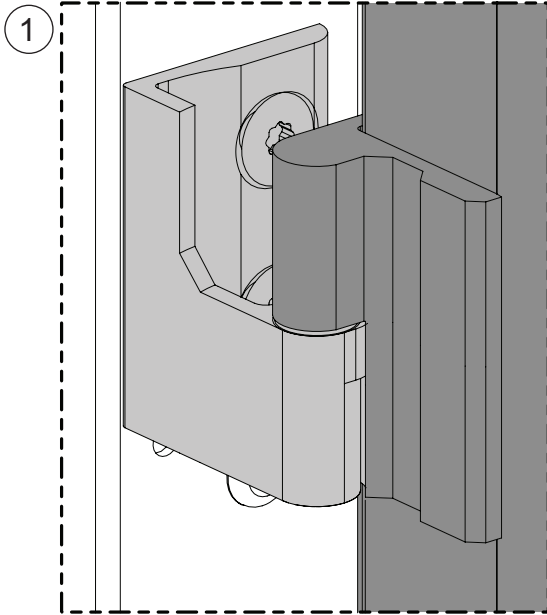

For Technical Support: www.panduit.com/resources/install_maintain.asp

Side Panels Removal

- Upper Panel must be removed before removing Lower Panel.
- Unlock Upper Side Panel and lift **UP**.
- Swing the bottom of the Upper Side Panel out to release from cabinet.
- Remove Upper Panel

1

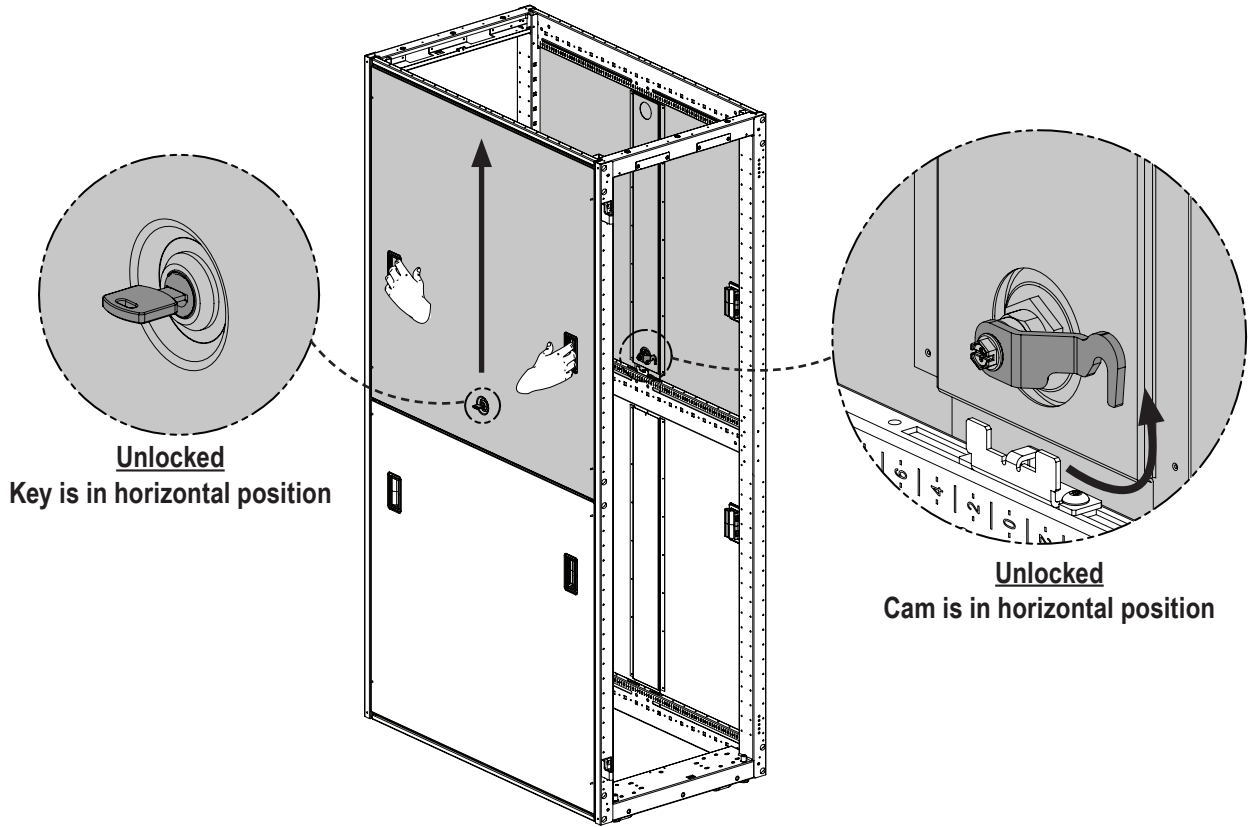

2

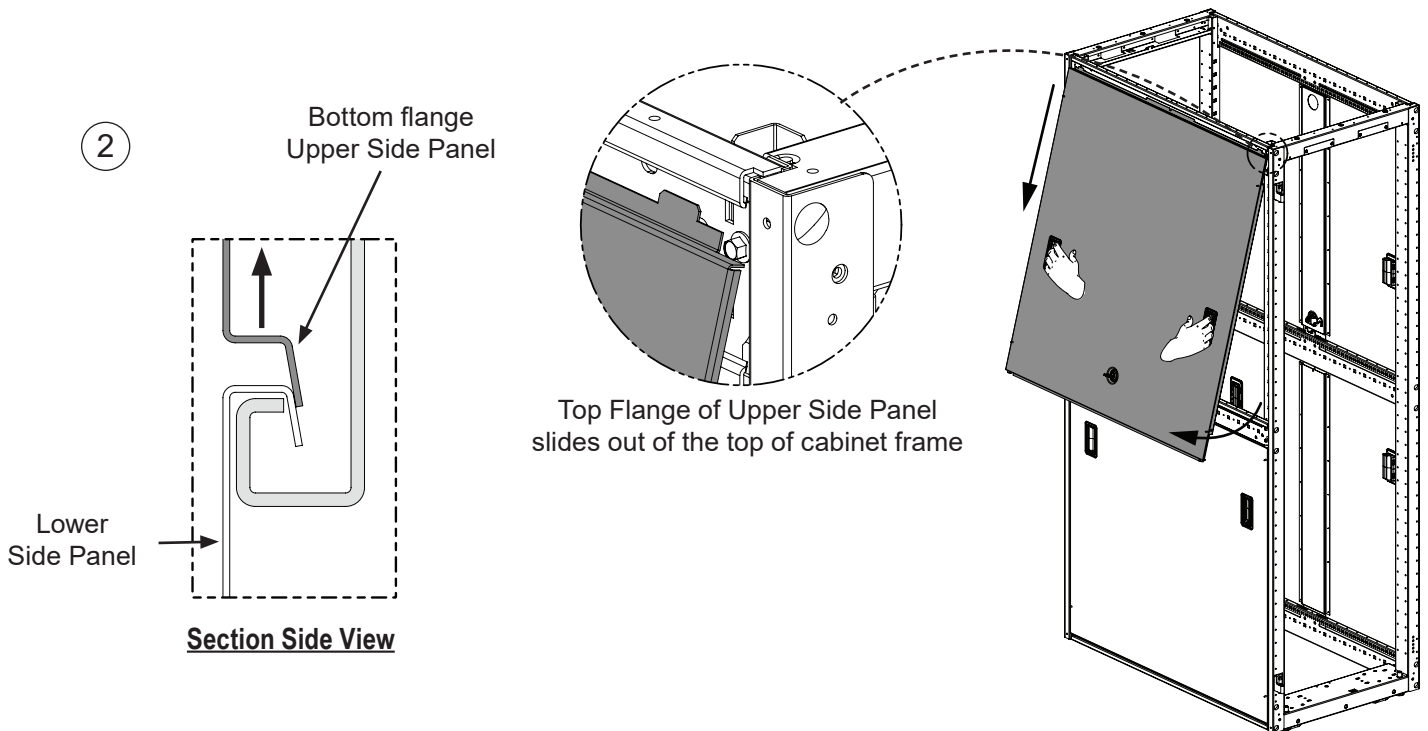

Side Panels (Removal and Installation)

- Lift up on the Lower Side Panel and pull away from cabinet using two handles.
- **Reverse Steps** to install Side Panels.

3

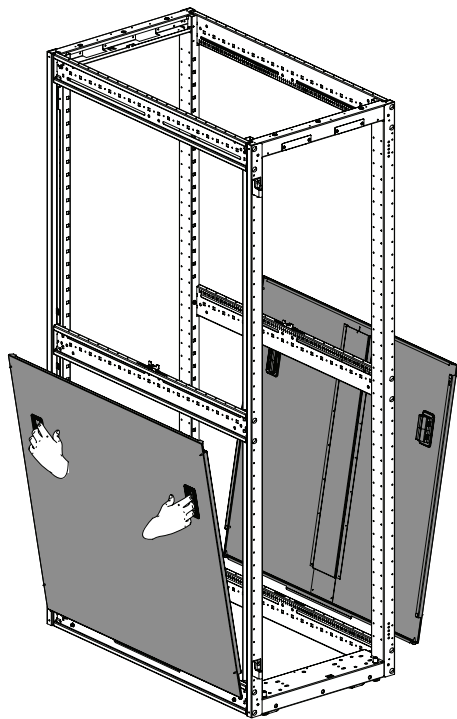
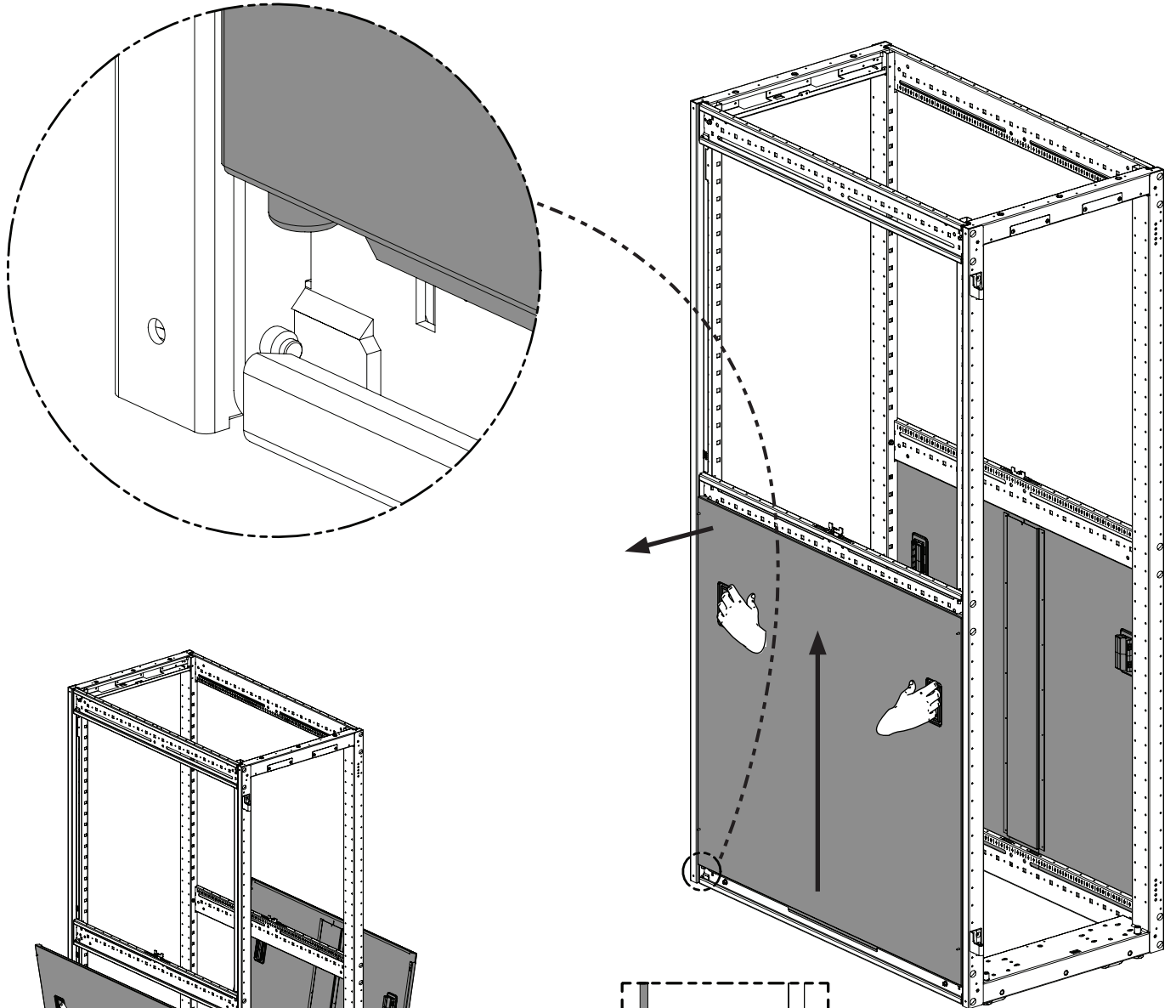

REINSTALLING LOWER PANEL
Install bottom flange into the bottom
Frame Beam first

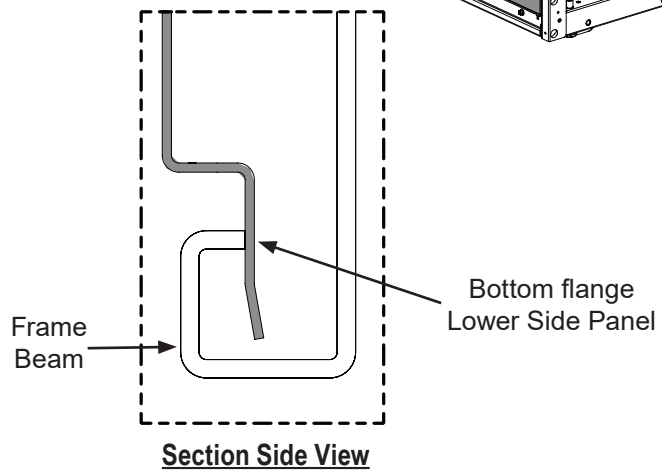

PDU Bracket Adjustment (Removal and Installation)

- PDU Brackets are height adjustable if PDU spacing other than factory position is desired.
- If cabinet comes with PDU Brackets installed, they can come on left side, right side, or both sides.
- **Reverse Steps 1 through 4** when re-positioning PDU Brackets at desired positions.

Maximum Applied Load PDU Brackets is 70 lbs

1 Remove (1) M5 screw

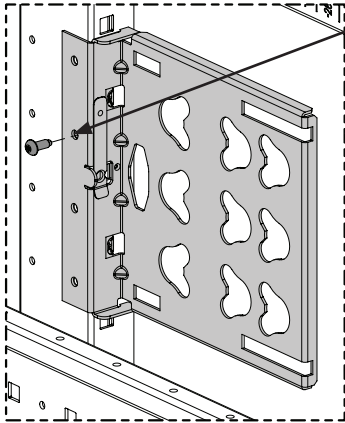

T25 Torx driver

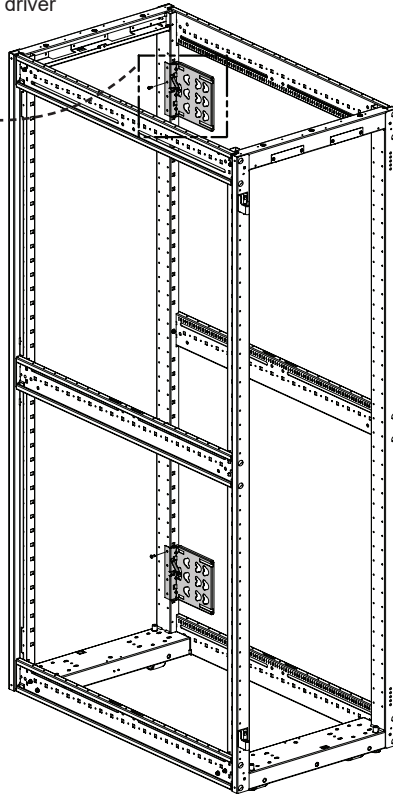

2 Disengage spring clip

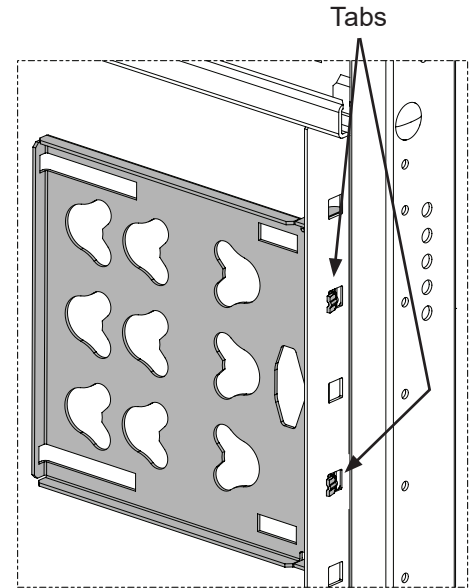
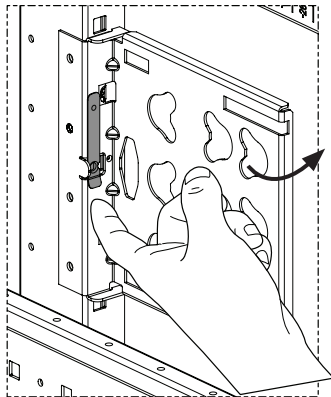

Backside View

PDU Bracket Tabs engage the cage nut holes on vertical post of cabinet frame

3 Slide PDU Bracket Tabs out from cabinet post

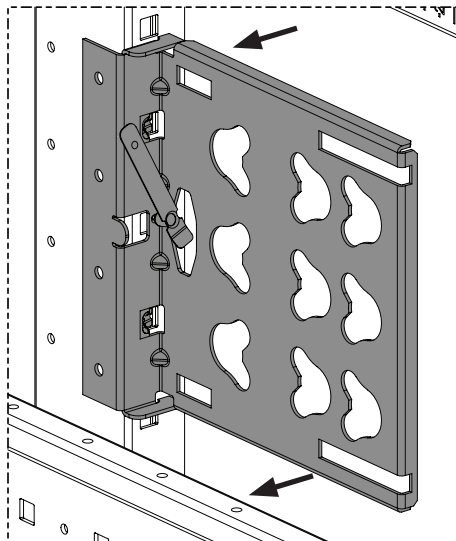

4 Remove PDU Bracket

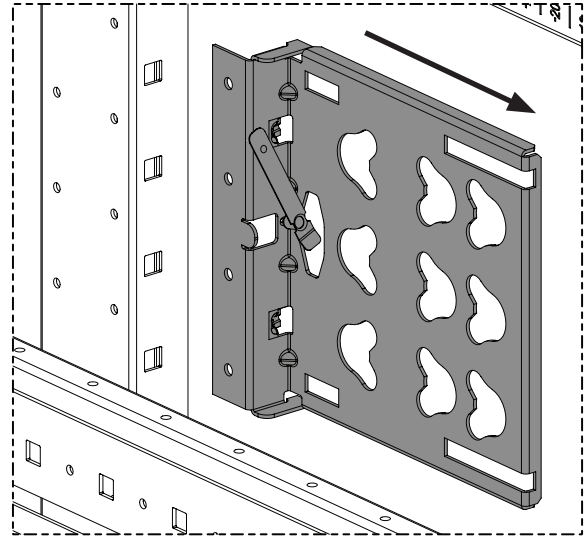

For Technical Support: www.panduit.com/resources/install_maintain.asp

Vertical Cable Management Panel (VCMP) (Removal and Installation)

- The VCMP can be repositioned inside cabinet if position other than factory position is desired.
- Disengage spring clip and lift up on the VCMP as shown below.
- **Reverse Steps 1 & 2** when repositioning the VCMP at desired position.

1 Disengage spring clip

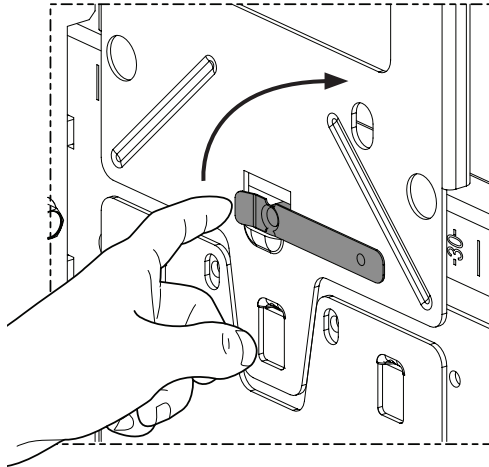

Maximum Applied Load per Panel is 75 lbs

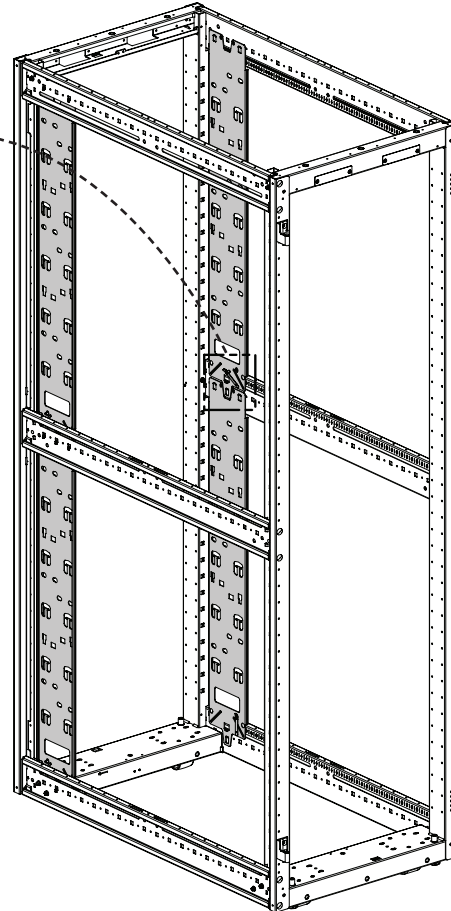

2 Rotate spring clip to the unlocked position

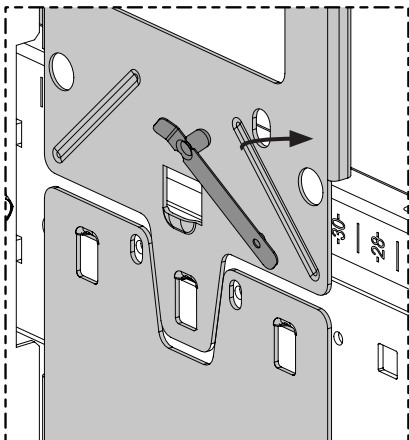

3 Lift UP on VCMP

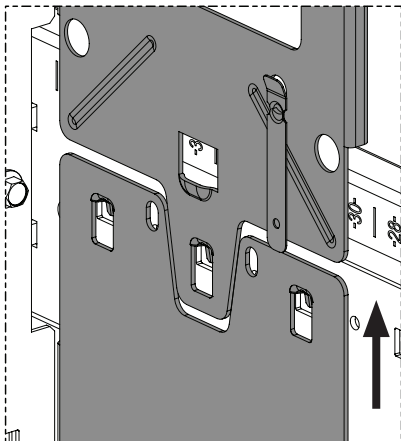

4 Pull out VCMP when tabs release

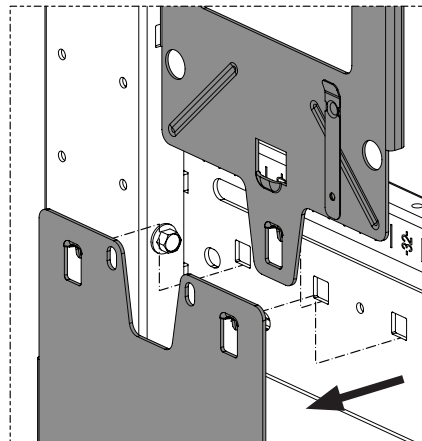

Tabs

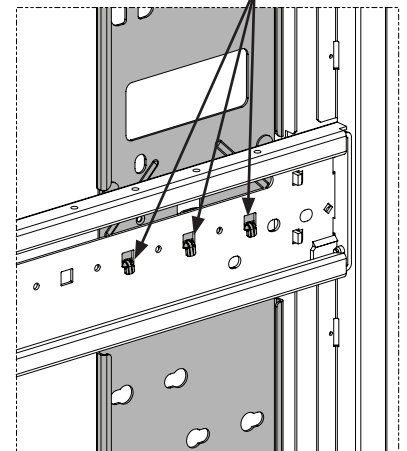

Backside View

VCMP Tabs engage the cage nut holes on Front-to-Back Beam of cabinet frame

OPTIONAL GROUNDING

M5 screw - Install only (1) screw for each Vertical Cable Management Panel installed.

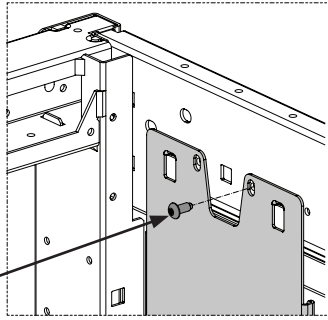

T25 Torx driver

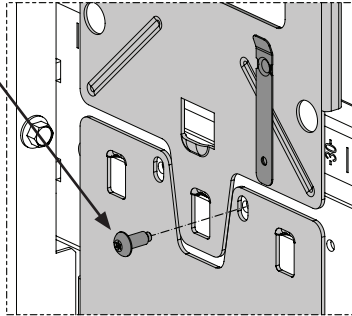

Moving and Re-installing Vertical Cable Managers

Align the (2) tabs at the **TOP** of the VCMP to the desired cage nut holes first

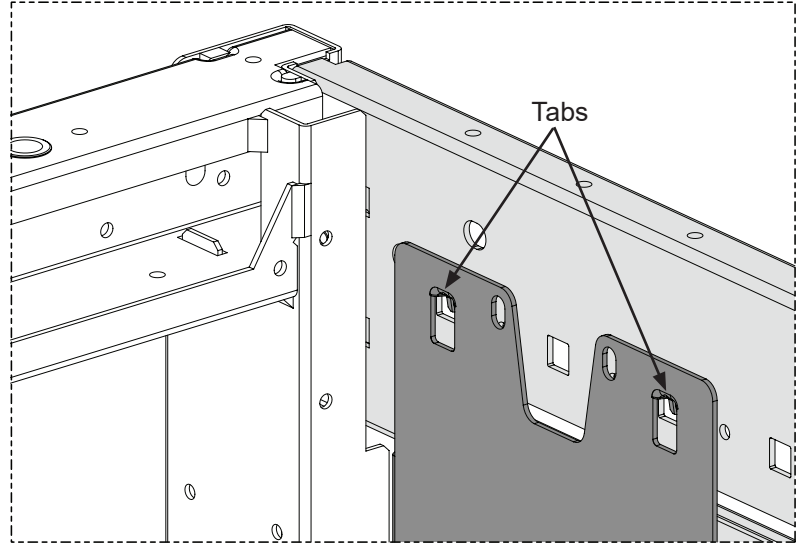

Vertical Cable Management Panel KEEP-OUT Areas for Side Panel Interference

1070mm Wide

Due to Side Panel interference, the VCMP cannot be installed 75mm (2 cage nuts over) left or right from center on 1070mm deep cabinets

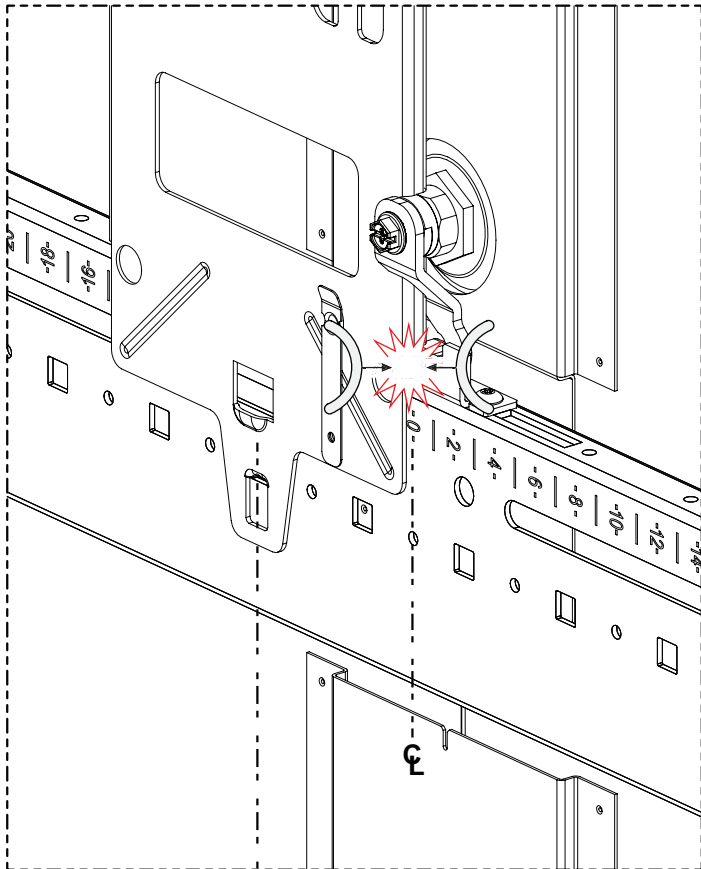

75mm from center
Both sides

1200mm Wide

Due to Side Panel interference, the VCMP cannot be installed 50mm (1 cage nut over) left or right from center on 1200mm deep cabinets

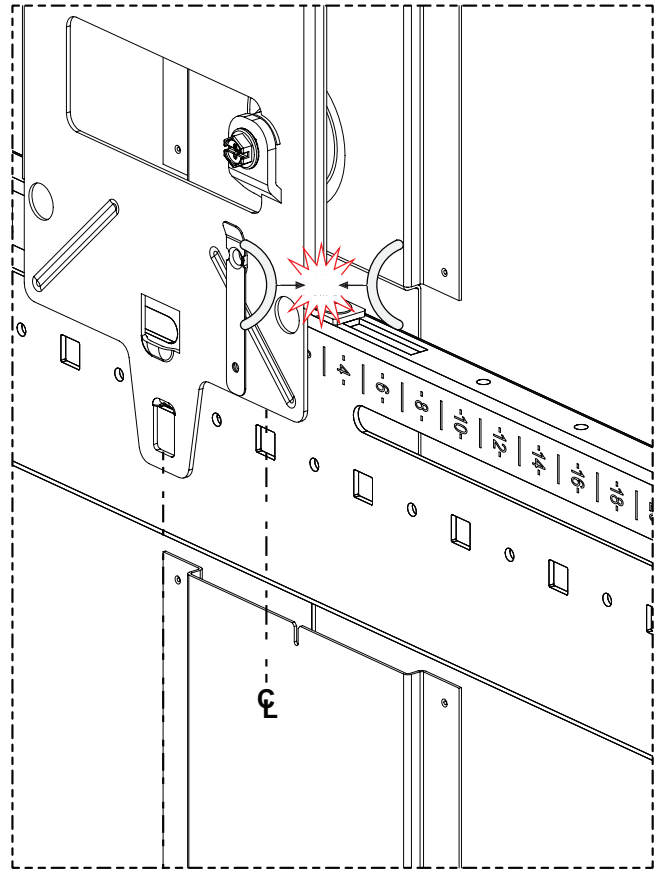

50mm from center
Both sides

For Instructions in Local Languages and Technical Support:

www.panduit.com/resources/install_maintain.asp



www.panduit.com

E-mail: techsupport@panduit.com

Phone: 866-405-6654