

THIS COPY IS PROVIDED ON A RESTRICTED BASIS AND IS NOT TO BE USED IN ANY WAY DETRIMENTAL TO THE INTERESTS OF PANDUIT CORP.

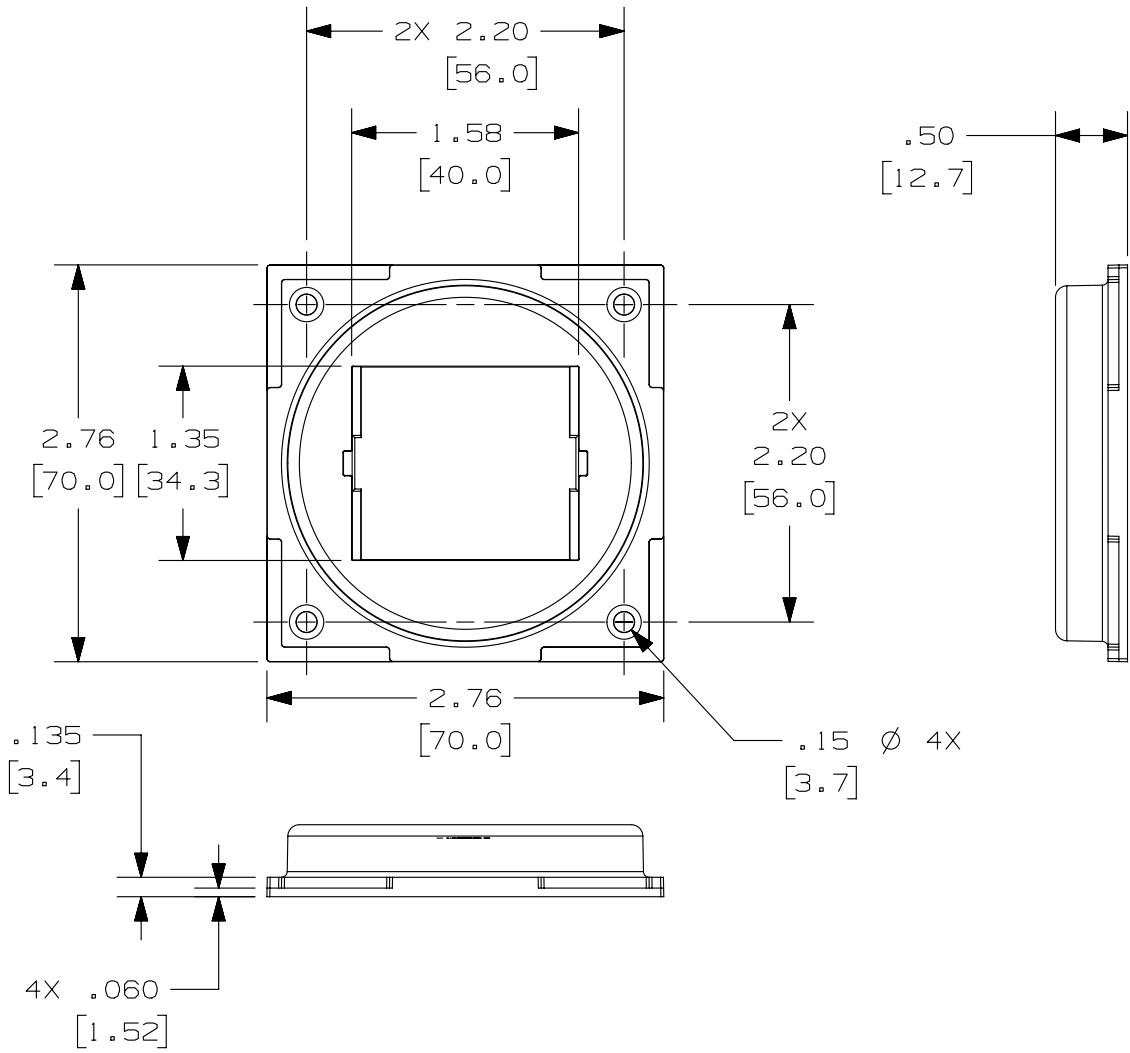

PANDUIT P/N	WEIGHT
CBCH**	.345 lb/10 pcs. 157.0 g/10 pcs.

- NOTES:
- ** 1. SEE CURRENT CATALOG FOR ADDITIONAL PART NUMBER SUFFIXES TO INDICATE COLOR AND OR PACKAGE QUANTITY.
 - 2. SEE CATALOG FOR COMPLETE LIST OF PARTS APPLICABLE FOR USE WITH THIS PART.
 - B 3. ACCEPTS ONE 1/2 SIZE MODULE INSERT.
 - 4. DIMENSIONS IN PARENTHESES ARE IN METRIC.
 - C 5. FOR USE WITH FELLER* TRUNKING BOX.
- * FELLER IS A DIVISION OF SCHNEIDER ELECTRIC.

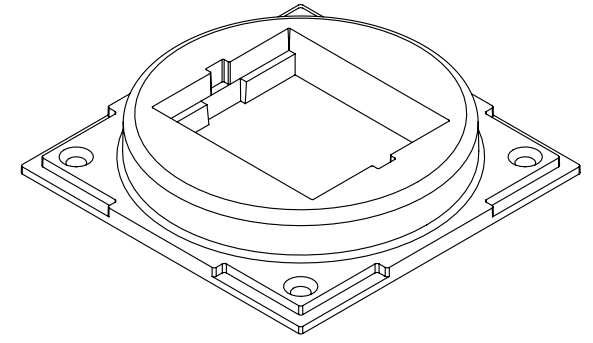

PART NUMBER CBCH**		PRODUCT SPEC/PKG SPEC N/A	
I.I. NUMBER N/A		WORK INSTRUCTION N/A	
TITLE 64MM ROUND SWITZERLAND BEZEL			
CUSTOMER DRAWING			
ITEM REVISION NAME M00008BA/00.PRT		PANDUIT TM	
DATASET FILE NAME M00008BA_DC/00C.PRT			
UNLESS OTHERWISE SPECIFIED, DIMENSIONAL TOLERANCES ARE: IN [mm]		MATERIAL: ABS	
.x ± .xxx ± .010 [.3] .xx ± .03 [.8] ANGLES ±		DRAWING NUMBER: 00008-02	
		THIRD ANGLE PROJECTION	
DRAWN BY RCA	DATE 5-14-97	CHK HDW	SCALE NONE
REV		SHT 1 OF 1	
DATE		SIZE A	

REV	DATE	BY	CHK	APR	DESCRIPTION	ECN
2	7/01/13	MDJR	JSP	JSP	C. ADDED NOTE 5. B. REVISED NOTE 3 TO SAY ONE 1/2 SIZE MODULE INSERT.	
1	11/6/12	BJN	JSP	JSP	A. UPDATED FORMAT TO REFLECT CURRENT PANDUIT LOGO	00008-02
R	5-14-97	RCA	HDW	HDW	RELEASED TO PRODUCTION	00008-02