

THIS COPY IS PROVIDED ON A RESTRICTED BASIS AND IS NOT TO BE USED IN ANY WAY DETRIMENTAL TO THE INTERESTS OF PANDUIT CORP.

NOTES:

1. VISIT OUR ON-LINE CATALOG AT WWW.PANDUIT.COM FOR A LIST OF CURRENT PARTS APPLICABLE FOR USE WITH THIS PRODUCT
2. DIMENSIONS IN [ ] ARE METRIC.
3. ALL MATERIALS AND COMPONENTS USED MEET THE MATERIAL RESTRICTIONS OF RoHS (EUROPEAN DIRECTIVE 2011/65/EU ON THE RESTRICTION OF HAZARDOUS SUBSTANCES) AS PROPOSED BY THE RoHS TECHNICAL ADAPTATION COMMITTEE.
4. TOP AND BOTTOM CLEAT SHELLS ARE 316L SS FASTENERS AND PIN ARE 18-8 SS.
5. MEETS IEC 61914:2015 SPECIFICATIONS
6. MOUNTING FASTENERS ARE NOT INCLUDED IN THE PACKAGE AND MUST BE PURCHASED SEPARATELY.
7. SELECT M8 OR 3/8" BOLT LENGTH SUITABLE FOR THE RUNG.
8. CABLE CLEAT BRACKET, PART NUMBER CBH#L##-V6, IS SOLD SEPARATELY
9. CONTACT PANDUIT SALES FOR CUSTOMIZED SOLUTIONS.

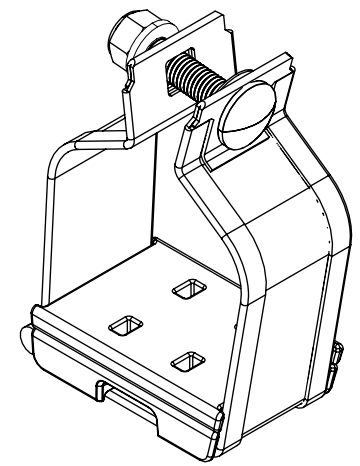

PART NUMBER	CABLE DIAMETER RANGE in. [ mm ]	"H" in. [ mm ]	"W" in. [ mm ]	"D" in. [ mm ]	WEIGHT lbs [ g ]
CCSSQD2226-X	0.87-1.02 [ 22-26 ]	4.05 [ 103 ]	2.76 [ 70 ]	2.48 [ 63 ]	.90 lbs [ 404 g ]
CCSSQD2529-X	0.98-1.14 [ 25-29 ]	4.42 [ 112 ]	3.02 [ 76.7 ]	2.48 [ 63 ]	.94 lbs [ 426 g ]
CCSSQD2834-X	1.10-1.34 [ 28-34 ]	4.80 [ 122 ]	3.46 [ 88 ]	2.48 [ 63 ]	1.05 lbs [ 477 g ]
CCSSQD3339-X	1.30-1.54 [ 33-39 ]	5.30 [ 135 ]	3.97 [ 101 ]	2.48 [ 63 ]	1.13 lbs [ 512 g ]
CCSSQD3844-X	1.50-1.73 [ 38-44 ]	5.77 [ 147 ]	4.39 [ 112 ]	2.48 [ 63 ]	1.25 lbs [ 566 g ]

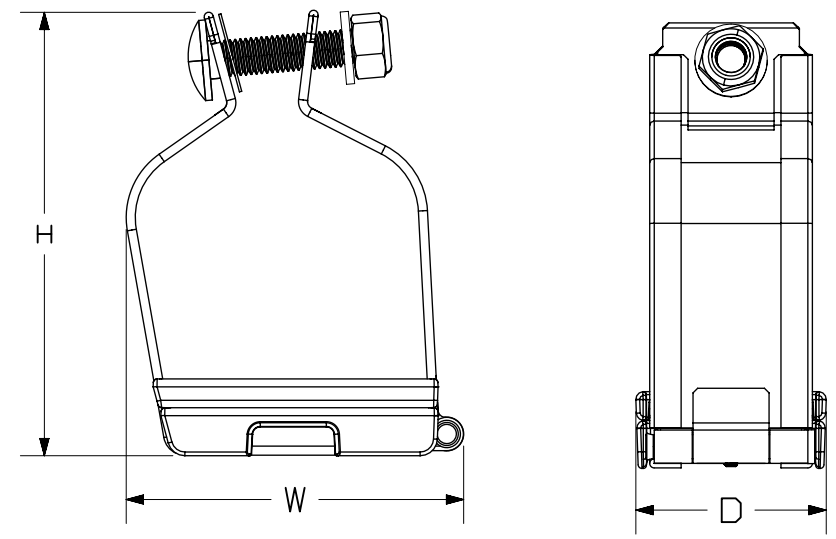

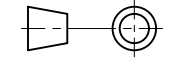
<b>STAINLESS STEEL QUAD CABLE CLEAT</b>					
CUSTOMER DRAWING					
ITEM REVISION NAME 00653ENZ/00			<b>PANDUIT</b>		
DATASET FILE NAME 00653ENZ-DC/00A					
 THIRD ANGLE PROJECTION			DRAWING NUMBER 00653ENZ_DC		
MATERIAL 316L STAINLESS STEEL			SCALE		
DRAWN BY DFTR	DATE 4/28/21	CHK ADAH	SCALE NONE		SIZE A
SHEET 1 OF 1					

A-SIZE CUSTOMER

00A	08/25/21	ACC	ADAH	ALP	INITIAL RELEASE	104453
REV	DATE	BY	CHK	APR	DESCRIPTION	ECN