

THIS COPY IS PROVIDED ON A RESTRICTED BASIS AND IS NOT TO BE USED IN ANY WAY DETRIMENTAL TO THE INTERESTS OF PANDUIT CORP.

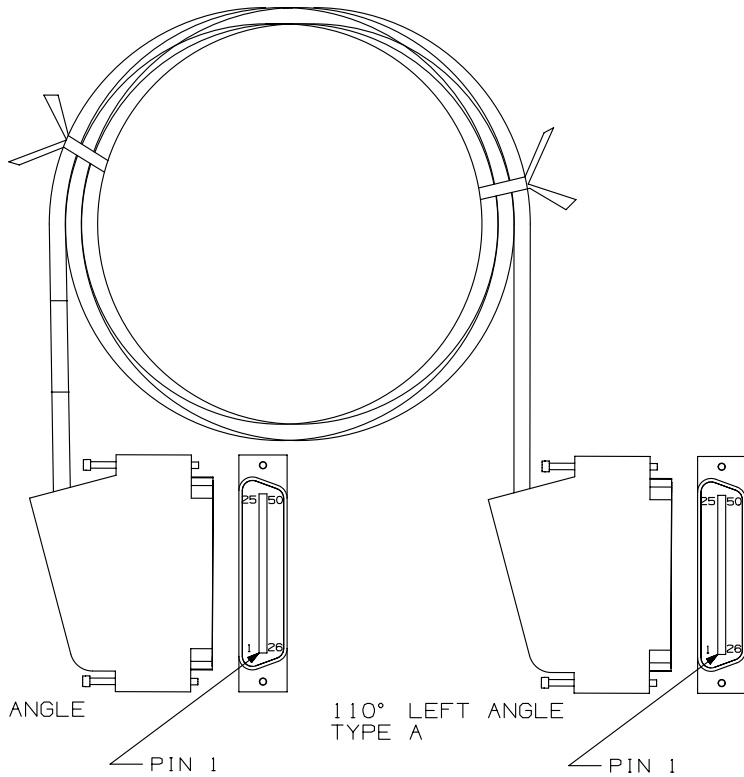

110° LEFT ANGLE
TYPE A

110° LEFT ANGLE
TYPE A

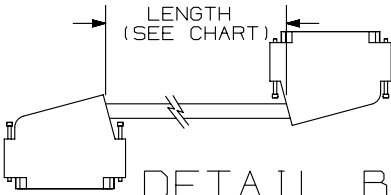

DETAIL B

CABLE LENGTH

PART NUMBER	LENGTH +6" (152.4)/-2" (50.8)	WEIGHT
UTPCH8L25Y	8' (2438.4)	1.20 LB/EACH (545 G/EACH)
UTPCH10L25Y	10' (3048)	1.44 LB/EACH (654 G/EACH)
UTPCH15L25Y	15' (4572)	2.05 LB/EACH (932 G/EACH)
UTPCH20L25Y	20' (6096)	2.66 LB/EACH (1209 G/EACH)
UTPCH6L25Y	6' (1829)	.96 LB/EACH (435 G/EACH)

NOTES:

1. SEE CURRENT CATALOG TO INDICATE PACKAGE QUANTITY.
2. SEE CATALOG FOR COMPLETE LIST OF PARTS APPLICABLE FOR USE WITH THIS PART.
3. MATES WITH FEMALE RJ21 CONNECTOR AND 10/100 BASE T PATCH PANEL.
4. CATEGORY 5 AND POWER SUM RATED.
5. DIMENSIONS IN PARENTHESES ARE IN METRIC.

PART NUMBER		UTPCH**L25Y	
TITLE			
25 PAIR PATCH CORD ASSEMBLY TWO 110° LEFT RJ21 MALE CONNECTORS			
CUSTOMER DRAWING			
ITEM REVISION NAME		M02479KM/00	
DATASET FILE NAME		M02479KM_DC274/00B	
UNLESS OTHERWISE SPECIFIED, DIMENSIONAL TOLERANCES ARE: IN (mm)		MATERIAL:	
.x ± .xxx ± .010 (.3)		CONNECTOR HSG: UL94 V-0 THERMOPLASTIC CABLE JACKET: PVC	
.xx ± .03 (.8) ANGLES ±		DRAWING NUMBER:	
THIRD ANGLE PROJECTION		02479-274	
DRAWN BY	DATE	CHK	SCALE
NER	3-20-06	WJC	NONE
SHT 1 OF 1			SIZE
			A

REV	DATE	BY	CHK	APR	DESCRIPTION	ECN
1	4-7-14	BJN	JSP	EJH	REVISED & REDRAWN PREVIOUS REVISIONS REMVD FOR CLARITY	02479-274

D10100DA/14