

TX6™ PLUS Category 6 UTP 3-Piece Modular Plug

SPECIFICATIONS

Category 6/Class E, 8-position, 8-wire, UTP 3-piece modular plug shall terminate 4-pair, 23–24 AWG, 100 ohm, solid or stranded unshielded twisted pair patch cable with maximum conductor insulation diameter of 0.042 inch (1.07mm) and maximum jacket diameter of 0.250 inch (6.35mm).



TECHNICAL INFORMATION

Category 6/Class E performance:	Exceeds ANSI/TIA Category 6 and ISO Class E performance requirements when properly terminated to Category 6 UTP copper cable
Cable jacket diameter range, in. (mm):	0.225-0.250 (5.72-6.35)
Conductor insulation diameter range, in. (mm):	0.036-0.042 (0.91-1.07)
FCC and ANSI compliance:	Meets ANSI/TIA-1096-A (formerly FCC Part 68)
IEC compliance:	IEC-60603-7
PoE compliance:	Supports PoE, PoE+, and proposed Type 3 and 4 PoE++ applications for up to 100W
Safety compliance:	cULus Listed; UL 1863 and CAN/CSA-C22.2 (UL File E129886)
RoHS compliance:	Compliant
Conductor termination:	Compatible with 23-24 AWG solid or stranded Category 6 UTP patch cable
Plug housing:	UL94V-0 rated clear polycarbonate
Contacts:	Gold plated phosphor bronze
Operating temperature:	14°F to 140°F (-15°C to 60°C)
Storage temperature:	-40°F to 158°F (-40°C to 70°C)

KEY FEATURES AND BENEFITS

Three-piece design:	Speeds and simplifies terminating plug onto cable
Patented tangle-free latch:	Prevents snags and provides easy release, saving time and providing reliability on frequent moves, adds, and changes
Robust construction:	Rated to 2500 mating cycles

APPLICATIONS

Category 6 plugs allow customers to meet performance requirements in ISO 11801 Class E, IEEE 802.3an-2006 and ANSI/TIA-568-C.2 Category 6 standards to support transmission at speeds up to and including 1000BASE-T.

These plugs can be used in applications such as high performance workstations, 155 Mb/s ATM, 622 Mb/s ATM, 1.2 Gb/s ATM, Token Ring 4/16, digital video and broadband/baseband analog video, and Voice over IP.

Category 6 UTP Modular Plug

Bulk pack (100 pieces): SP688E-C

Tools and Accessories

Termination tool: CSPT

Crimp tool: MPT5-8AS

RJ45 plug lock-in device (standard): PSL-DCPLE**+

RJ45 plug lock-in device (recessed): PSL-DCPLRE**+

**Colors other than Red: -BL (Black), -BU (Blue), -GR (Green), -YL (Yellow), -OR (Orange), IW (International White), or -IG (International Gray)
+Add -X for packages of 10 or -C for packages of 100 packages of 100.



All Part Numbers Compliant with the U.S. Trade Agreements Act (TAA) for purchases shipped to the United States.

TX6 PLUS Category 6 UTP 3-Piece Modular Plug

ENGINEERING DRAWINGS

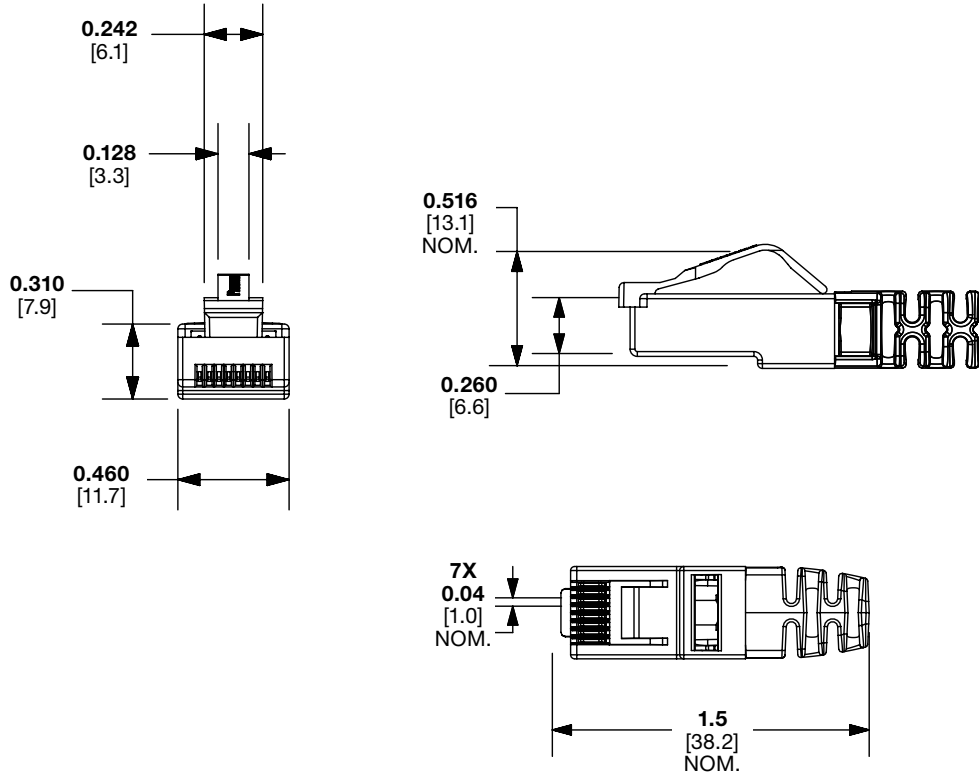

STRAIN COLLAR WITH INTEGRAL BOOT & CONDUCTOR DIVIDER

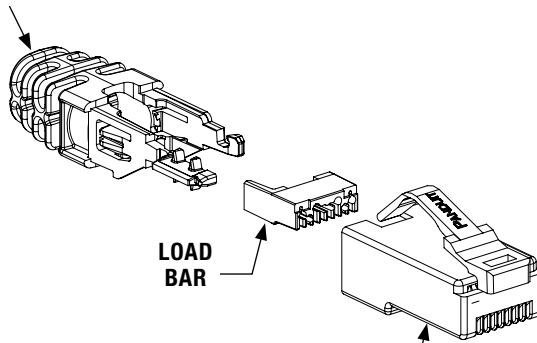

LOAD BAR

PLUG HOUSING WITH CONTACTS

Dimensions are in inches. [Dimensions in brackets are metric].

WORLDWIDE SUBSIDIARIES AND SALES OFFICES

PANDUIT US/CANADA
Phone: 800.777.3300

PANDUIT EUROPE LTD.
London, UK
Phone: 44.20.8601.7200

PANDUIT SINGAPORE PTE. LTD.
Republic of Singapore
Phone: 65.6305.7575

PANDUIT JAPAN
Tokyo, Japan
Phone: 81.3.6863.6000

PANDUIT LATIN AMERICA
Guadalajara, Mexico
Phone: 52.33.3777.6000

PANDUIT AUSTRALIA PTY. LTD.
Victoria, Australia
Phone: 61.3.9794.9020

For a copy of Panduit product warranties, log on to www.panduit.com/warranty

For more information

Visit us at www.panduit.com
Contact Customer Service by email: cs@panduit.com
or by phone: 800.777.3300

PANDUIT[®]

© 2023 Panduit Corp.
ALL RIGHTS RESERVED.
COSP553-WW-ENG
10/2023