

THIS COPY IS PROVIDED ON A RESTRICTED BASIS AND IS NOT TO BE USED IN ANY WAY DETRIMENTAL TO THE INTERESTS OF PANDUIT CORP.

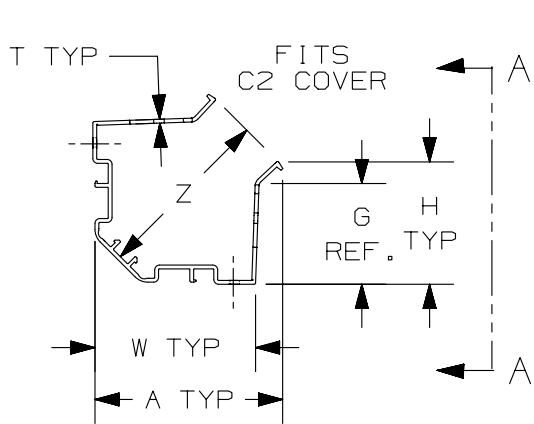

CWD 2"

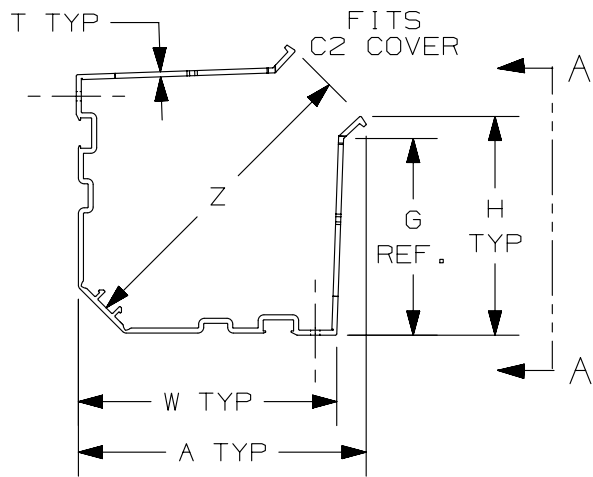

CWD 3" & 4"

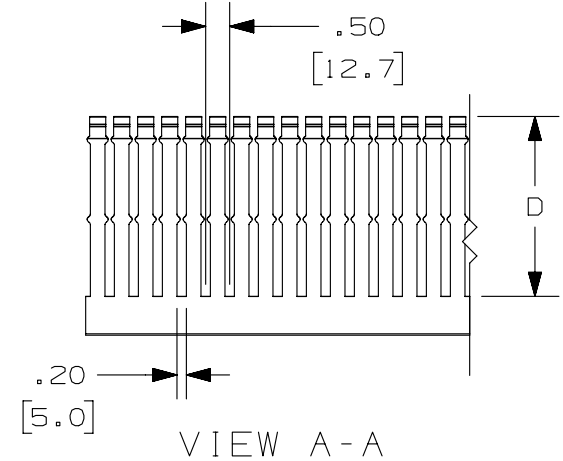

VIEW A-A

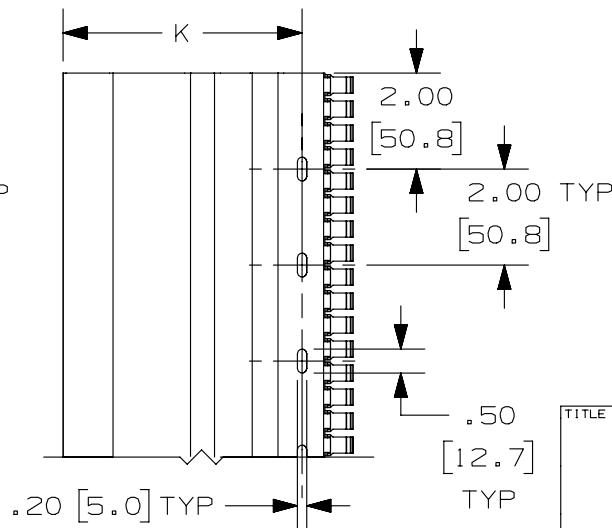
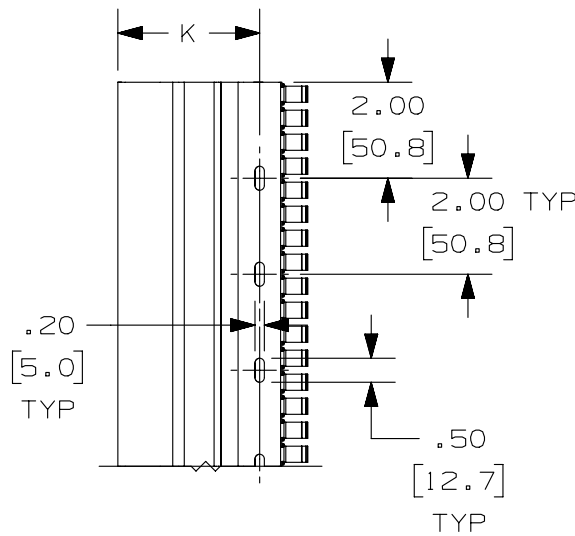

NOTES:

1. "W" MEASURED AT BASE.
2. STANDARD LENGTH: 6ft. (1.83m)
3. SEE CURRENT CATALOG FOR ADDITIONAL PART NUMBER SUFFIXES TO INDICATE COLOR AND OR PACKAGE QUANTITY.
4. FOR USE WITH C2**6 COVER. (SEE DRAWING # 34518-17.)
5. FOR USE WITH CDCLP2, CDCLP3 OR CDCLP4. (SEE DRAWING # 39178-04.)
6. FOR USE WITH CDLB3 OR CDLB4. (SEE DRAWING # 39257-07.)



TITLE		WIRING DUCT SPECIFICATIONS TYPE "CWD" CORNER DUCT	
		CUSTOMER DRAWING	
ITEM REVISION NAME		D39210AB/03	
DATASET FILE NAME		D39210AB_DC_CWD/03B	
UNLESS OTHERWISE SPECIFIED, DIMENSIONAL TOLERANCES ARE: IN [mm]		MATERIAL:	
.x ± .1 [.25] .xx ± .04 [.1]		PVC	
.xxx ± ANGLES ±		DRAWING NUMBER:	
 THIRD ANGLE PROJECTION		39210-03	
DRAWN BY	DATE	CHK	SCALE
JCST	01-26-06	JKG	NONE
REV		SHT 1 OF 2	
DATE		A	

3	03-16-13	JBN	RTFI	RTFI	G. UPDATED DRAWING BORDER & TITLE BLOCK	39210-03
REV	DATE	BY	CHK	APR	DESCRIPTION	ECN

D10100DA/15

THIS COPY IS PROVIDED ON A RESTRICTED BASIS AND IS NOT TO BE USED IN ANY WAY DETRIMENTAL TO THE INTERESTS OF PANDUIT CORP.

PART NO.	A	D	G	H	K	T	W	Z
CWD2**6	3.91	1.81	2.10	2.57	2.93	.08	3.35	3.72
	99.3	45.9	53.4	65.3	74.3	2.0	85.0	94.6
CWD3**6	4.98	2.83	3.10	3.57	3.88	.10	4.40	5.16
	126.6	71.8	79.1	90.7	98.6	2.4	111.8	131.0
CWD4**6	5.94	3.84	4.10	4.58	4.93	.11	5.33	6.54
	150.9	97.5	104.1	115.7	125.2	2.7	135.3	166.0

** = COLOR

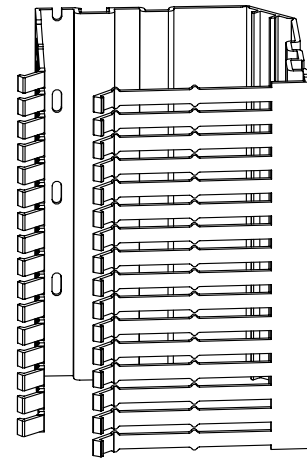
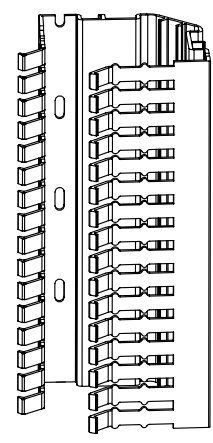

REV	DATE	BY	CHK	APR	DESCRIPTION	ECN
3	03-06-13	JBN	RTFI	RTFI	SEE SHEET 1 FOR REVISION DESCRIPTION	39210-03

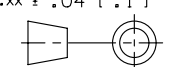
TITLE WIRING DUCT SPECIFICATIONS TYPE "CWD" CORNER DUCT		PANDUIT
CUSTOMER DRAWING		
ITEM REVISION NAME D39210AB/03		MATERIAL: PVC
DATASET FILE NAME D39210AB_DC_CWD/03B		
UNLESS OTHERWISE SPECIFIED, DIMENSIONAL TOLERANCES ARE: IN [mm] .x ± .1 [.25] .xxx ± .xx ± .04 [.1] ANGLES ±		DRAWING NUMBER: 39210-03
 THIRD ANGLE PROJECTION		
DRAWN BY JCST	DATE 01-26-06	CHK JKG
SCALE NONE		SIZE A

D10100DA/15