

THIS COPY IS PROVIDED ON A RESTRICTED BASIS AND IS NOT TO BE USED IN ANY WAY DETRIMENTAL TO THE INTERESTS OF PANDUIT CORP.

- NOTES:
- VISIT OUR ON-LINE CATALOG AT WWW.PANDUIT.COM FOR A LIST OF CURRENT PARTS APPLICABLE FOR USE WITH THIS PRODUCT.
 - ALL MATERIALS AND COMPONENTS USED MEET THE MATERIAL RESTRICTIONS OF RoHS (EUROPEAN DIRECTIVE 2011/65/EU ON THE RESTRICTION OF HAZARDOUS SUBSTANCES) AS PROPOSED BY THE RoHS TECHNICAL ADAPTATION COMMITTEE.
 - SINGLEMODE MPO AND SINGLEMODE PANMPO ARE ANGLED POLISH (APC)
 - CONFIGURATOR SHOWN ON PAGE 2.
 - BASE LENGTH AND STAGGER OPTIONS SHOWN ON PAGE 3.

LSZH CABLE	
FIBERS	OUTER DIAMETER
8	0.118" (3.0mm)
16	0.138" (3.5mm)

CONNECTORS		
DESCRIPTION	PICTURE	USED ON
MPO-8 FEMALE*		END A
MPO-8 MALE*		END A
PanMPO-8 FEMALE*		END A
PanMPO-8 MALE*		END A
MPO-16 APC MALE (OFFSET KEY)		END A
MPO-16 APC FEMALE (OFFSET KEY)		END A
LC UNIBOOT PUSH PULL*		END B
DUPLEX LC*		END B

* = OFFERED IN ANGLED OR FLAT POLISH SINGLEMODE METHOD A AND METHOD B PANMPO ARE NOT POLARITY REVERSIBLE.

8 FIBER HARNESS POLARITY				
FIBER COLOR	4 to 1 (U2)		4 to 1 PAIR FLIPPED (U)	
	MPO FERRULE POSITION (END A)	LC FIBER POSITION (END B)	MPO FERRULE POSITION (END A)	LC FIBER POSITION (END B)
BLUE	1	1-B	1	1-A
ORANGE	2	2-B	2	2-A
GREEN	3	3-B	3	3-A
BROWN	4	4-B	4	4-A
SLATE	9	4-A	9	4-B
WHITE	10	3-A	10	3-B
RED	11	2-A	11	2-B
BLACK	12	1-A	12	1-B

16 FIBER HARNESS POLARITY				
FIBER COLOR	8 to 1 (U2)		8 to 1 PAIR FLIPPED (U)	
	MPO FERRULE POSITION (END A)	LC FIBER POSITION (END B)	MPO FERRULE POSITION (END A)	LC FIBER POSITION (END B)
BLUE	1	1-B	1	1-A
ORANGE	2	2-B	2	2-A
GREEN	3	3-B	3	3-A
BROWN	4	4-B	4	4-A
SLATE	5	5-B	5	5-A
WHITE	6	6-B	6	6-A
RED	7	7-B	7	7-A
BLACK	8	8-B	8	8-A
YELLOW	9	8-A	9	8-B
VIOLET	10	7-A	10	7-B
ROSE	11	6-A	11	6-B
AQUA	12	5-A	12	5-B
BLUE-2	13	4-A	13	4-B
ORANGE-2	14	3-A	14	3-B
GREEN-2	15	2-A	15	2-B
BROWN-2	16	1-A	16	1-B

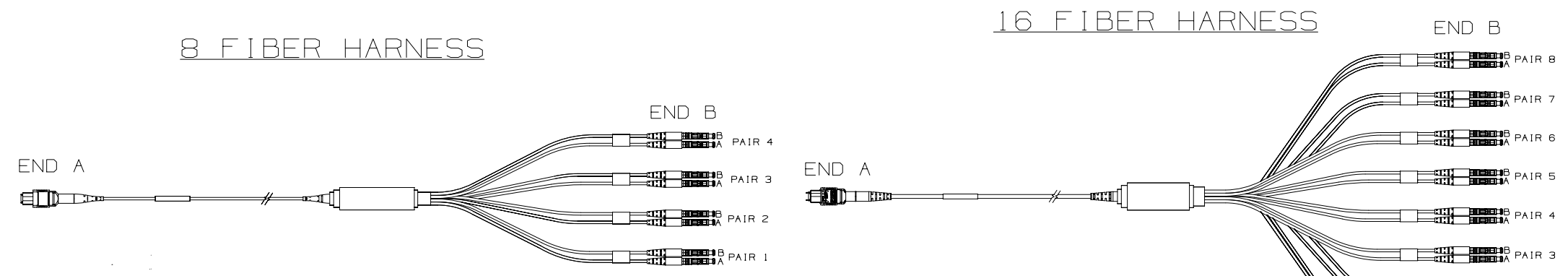

*HARNESSES SHOWN ABOVE SHOW DUPLEX LC'S (END B) TO MPO-8 OR MPO-16 CONNECTORS (END A). OTHER CONNECTORS AVAILABLE ARE SHOWN ON THIS PAGE.

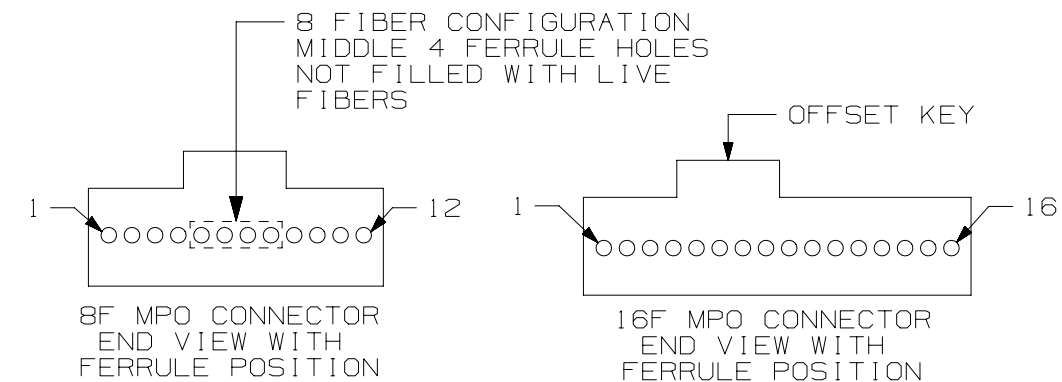

REV	DATE	BY	CHK	APR	DESCRIPTION	ECN
00A	08-07-23	SAT	BJBE	EJH	INITIAL RELEASE	02114EAK-DC

PART NUMBER		SEE CONFIGURATOR ON SHEET 2	
TITLE			
BASE-8 AND BASE-16 CONFIGURE TO ORDER LSZH HARNESS CABLE ASSEMBLY			
BASE 8: 8 FIBERS			
BASE 16: 16 FIBERS			
CUSTOMER DRAWING			
ITEM REVISION NAME		02114EAK/00	
DATASET FILE NAME		02114EAK_DC/00A	
MATERIAL		MULTIPLE	
DRAWN BY		SAT	
DATE		07/28/23	
CHK		BJBE	
SCALE		NONE	
DRAWING NUMBER		02114EAK-DC	
SHEET 1 OF 3		B	

B

B

A

A

B-SIZE CUSTOMER

CHARACTER	1	2	3	4	5	6	7	8	9-11	12	13-15
ATTRIBUTE	FIBER	PRODUCT/ CABLE TYPE	FIBER TYPE	FIBER COUNT	FLAME RATING	CONNECTOR TYPE (END 'A')	CONNECTOR TYPE (END 'B')	POLARITY/PERFORMANCE	SERIAL	UNITS	LENGTH (TIP TO TIP)
OPTIONS	F	H = HARNESS	9= SM	8 = 8F	L =LSZH	G = MPO-8 Female	P = LC Uniboot Push Pull	Q = 4 to 1 / U2 - Std. IL	XXX= SEE TABLE BELOW	F= FEET	001-300 FEET
			Z= OM4	C = 16F		H = MPO-8 Male	9 = LC Uniboot Push Pull APC	V = 4 to 1 / U2 - Opt. IL		M= METERS	0.5 -100 METERS
			S= OM4+			J = PanMPO-8 Female	L = Duplex LC	U = 4 to 1 / U2 - Ultra IL			
			W=OM5			K = PanMPO-8 Male	B = Duplex LC APC	1 = 4 to 1 Flipped Pair / U - Std. IL			
						O = MPO-16 APC Female		2 = 4 to 1 Flipped Pair / U - Opt. IL			
						M = MPO-16 APC Male		3 = 4 to 1 Flipped Pair / U - Ultra IL			
						X = MPO-8 Female APC		4 = 8 to 1 / U2 - Std. IL			
						Y = MPO-8 Male APC		5 = 8 to 1 / U2 - Opt. IL			
						V = PanMPO-8 Female APC		6 = 8 to 1 / U2 - Ultra IL			
						W = PanMPO-8 Male APC		7 = 8 to 1 Flipped Pair / U - Std. IL			
								8 = 8 to 1 Flipped Pair / U - Opt. IL			
								9 = 8 to 1 Flipped Pair / U - Ultra IL			

"SERIAL" COLUMN FROM ABOVE			
BASE 8 SERIAL #	BASE 16 SERIAL #	BASE LENGTH	STAGGER OPTION
011	021	18" (45cm)	No Stagger, Equal Breakout
012	022	18" (45cm)	LC Pair 1 Longest Stagger
013	023	18" (45cm)	LC Pair 1 Shortest Stagger
014	024	18" (45cm)	LC Pair 1 and 2 Longest Stagger
015	025	18" (45cm)	LC Pair 1 and 2 Shortest Stagger
016	026	24" (60cm)	No Stagger, Equal Breakout
017	027	24" (60cm)	LC Pair 1 Longest Stagger
018	028	24" (60cm)	LC Pair 1 Shortest Stagger
019	029	24" (60cm)	LC Pair 1 and 2 Longest Stagger
01A	02A	24" (60cm)	LC Pair 1 and 2 Shortest Stagger
01B	02B	30" (76cm)	No Stagger, Equal Breakout
01C	02C	30" (76cm)	LC Pair 1 Longest Stagger
01D	02D	30" (76cm)	LC Pair 1 Shortest Stagger
01E	02E	30" (76cm)	LC Pair 1 and 2 Longest Stagger
01F	02F	30" (76cm)	LC Pair 1 and 2 Shortest Stagger
01G	02G	36" (91cm)	No Stagger, Equal Breakout
01H	02H	36" (91cm)	LC Pair 1 Longest Stagger
01J	02J	36" (91cm)	LC Pair 1 Shortest Stagger
01K	02K	36" (91cm)	LC Pair 1 and 2 Longest Stagger
01L	02L	36" (91cm)	LC Pair 1 and 2 Shortest Stagger
01M	02M	39" (1m)	No Stagger, Equal Breakout
01N	02N	39" (1m)	LC Pair 1 Longest Stagger
01P	02P	39" (1m)	LC Pair 1 Shortest Stagger
01Q	02Q	39" (1m)	LC Pair 1 and 2 Longest Stagger
01R	02R	39" (1m)	LC Pair 1 and 2 Shortest Stagger
01S	02S	78" (2m)	No Stagger, Equal Breakout
01T	02T	78" (2m)	LC Pair 1 Longest Stagger
01U	02U	78" (2m)	LC Pair 1 Shortest Stagger
01V	02V	78" (2m)	LC Pair 1 and 2 Longest Stagger
01W	02W	78" (2m)	LC Pair 1 and 2 Shortest Stagger

PART NUMBER		SEE CONFIGURATOR ABOVE	
TITLE			
BASE-8 AND BASE-16 CONFIGURE TO ORDER LSZH HARNESS CABLE ASSEMBLY BASE 8: 8 FIBERS BASE 16: 16 FIBERS CUSTOMER DRAWING			
ITEM REVISION NAME		02114EAK/00	
DATASET FILE NAME		02114EAK_DC/00A	
MATERIAL		MULTIPLE	
DRAWN BY		SAT	
DATE		07/28/23	
CHK		BJBE	
SCALE		NONE	
DRAWING NUMBER		02114EAK - DC	
SHEET 2 OF 3		B	

REV	DATE	BY	CHK	APR	DESCRIPTION	ECN
					SEE REVISIONS ON SHEET 1	02114EAJ-DC

BASE LENGTH AND STAGGER OPTIONS
STAGGER OPTION

FIBER COUNT	BREAKOUT LENGTH OPTIONS	STAGGER OPTION				
		No Stagger, Equal Breakout	LC Pair 1 Longest Stagger	LC Pair 1 Shortest Stagger	LC Pair 1 and 2 Longest Stagger	LC Pair 1 and 2 Shortest Stagger
8	18" (45cm)					
	24" (60cm)					
	30" (76cm)					
	36" (91cm)					
	39" (1m)					
	78" (2m)					
16	18" (45cm)					
	24" (60cm)					
	30" (76cm)					
	36" (91cm)					
	39" (1m)					
	78" (2m)					

PART NUMBER
SEE CONFIGURATOR ON SHEET 2

TITLE
**BASE-8 AND BASE-16 CONFIGURE TO ORDER
LSZH HARNESS CABLE ASSEMBLY
BASE 8: 8 FIBERS
BASE 16: 16 FIBERS
CUSTOMER DRAWING**

ITEM REVISION NAME
02114EAK/00

DATASET FILE NAME
02114EAK_DC/00A

MATERIAL
MULTIPLE

DRAWING NUMBER
02114EAK-DC

THIRD ANGLE PROJECTION

DRAWN BY: SAT DATE: 07/28/23 CHK: BJBE SCALE: NONE

SHEET 3 OF 3

REV	DATE	BY	CHK	APR	DESCRIPTION	ECN
					SEE REVISIONS ON SHEET 1	02114EAJ-DC

B

B

A

A

B-SIZE CUSTOMER