

FIGURE 1

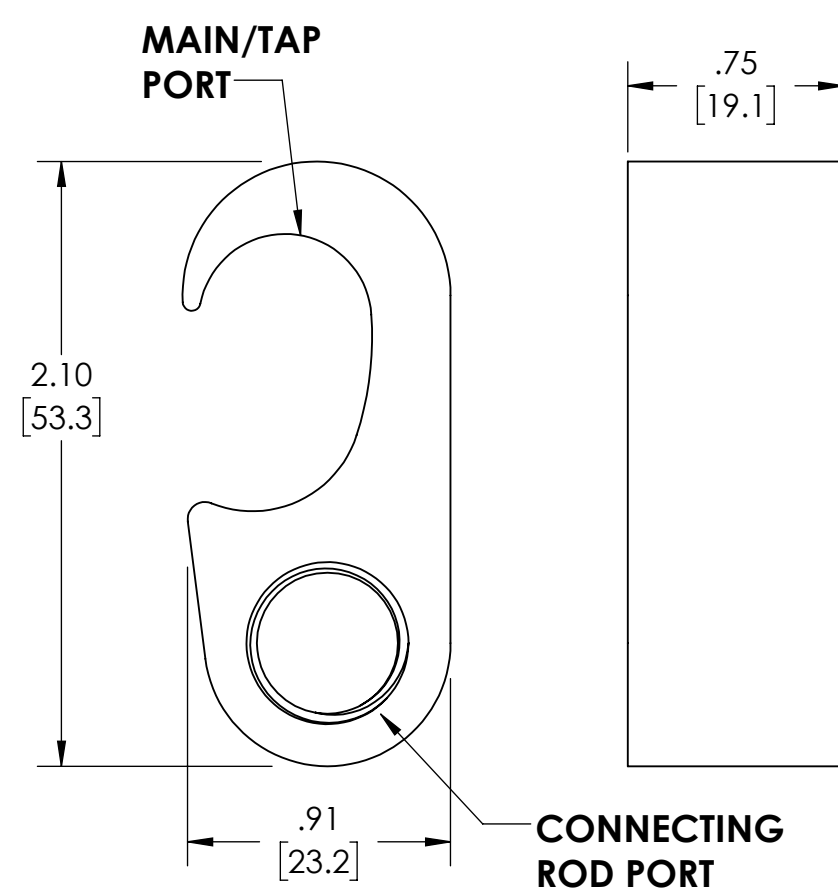

FIGURE 2

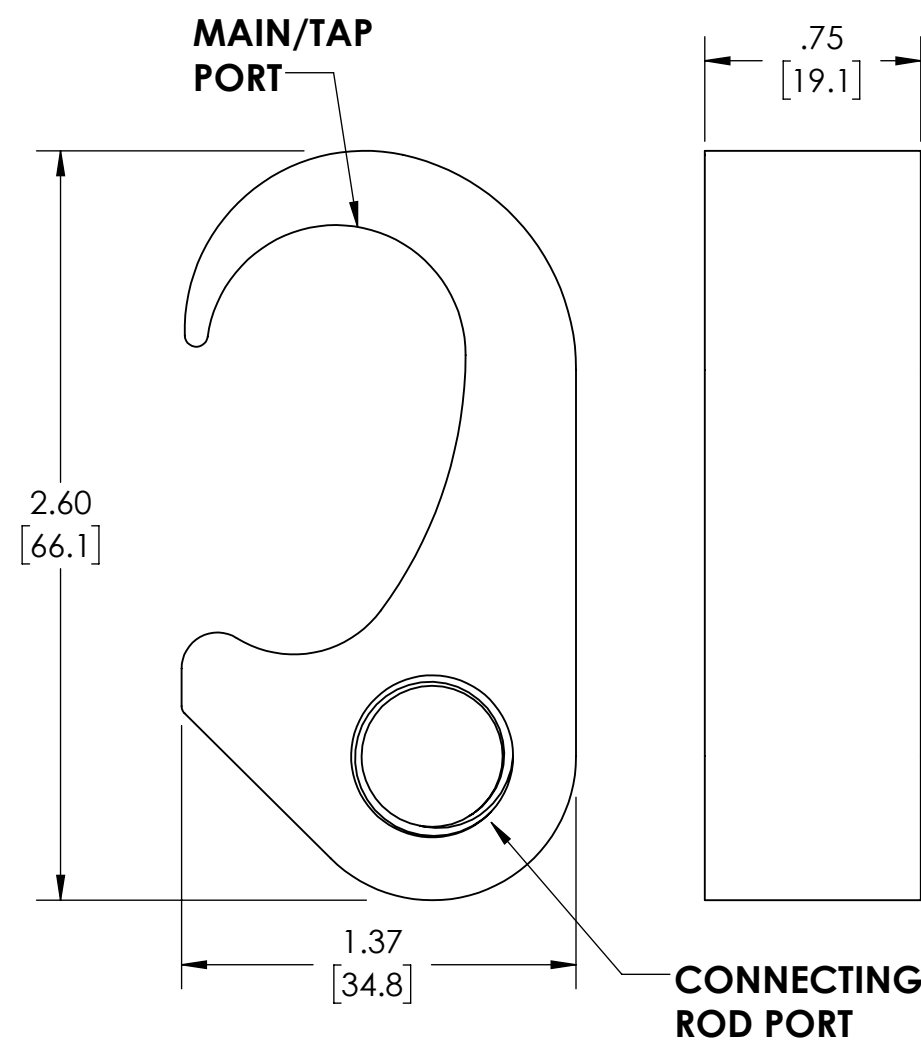

FIGURE 3

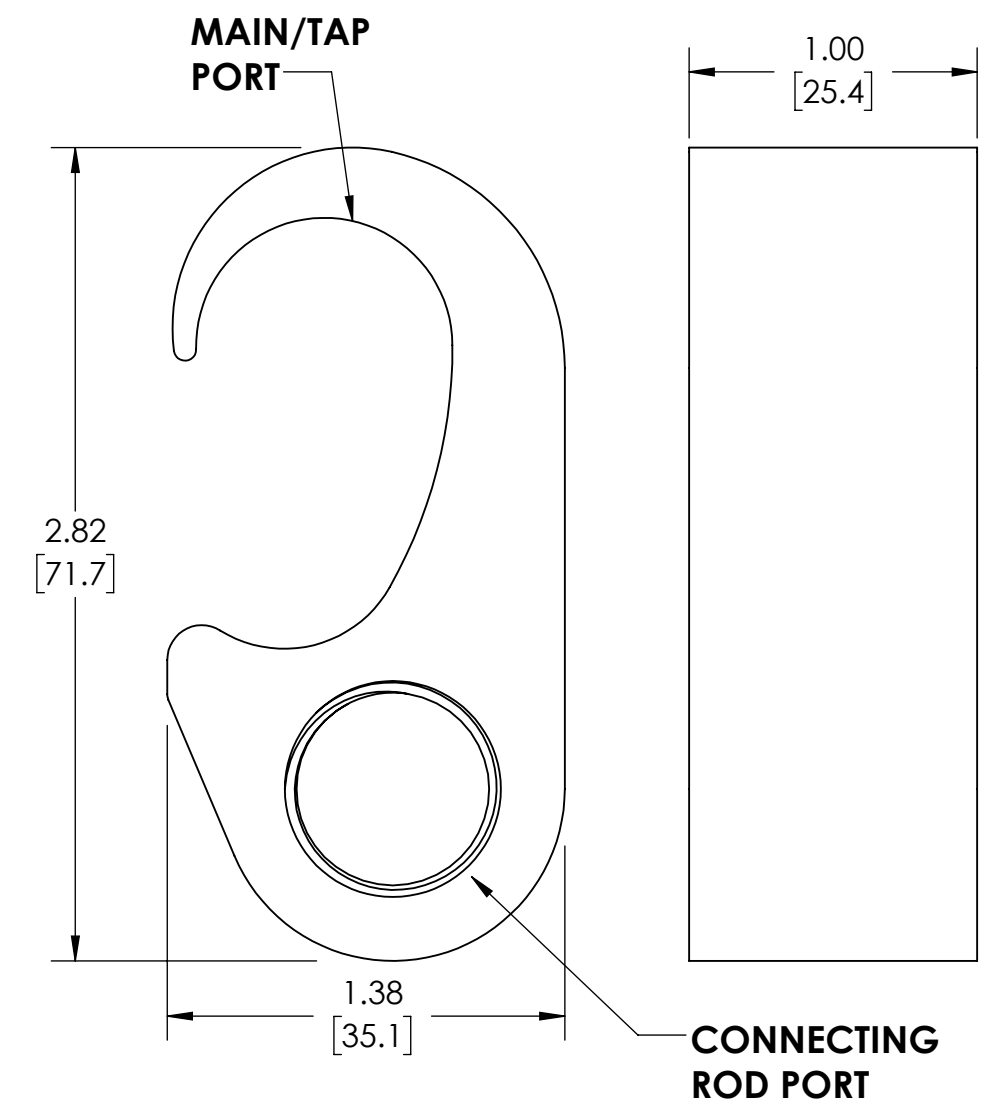
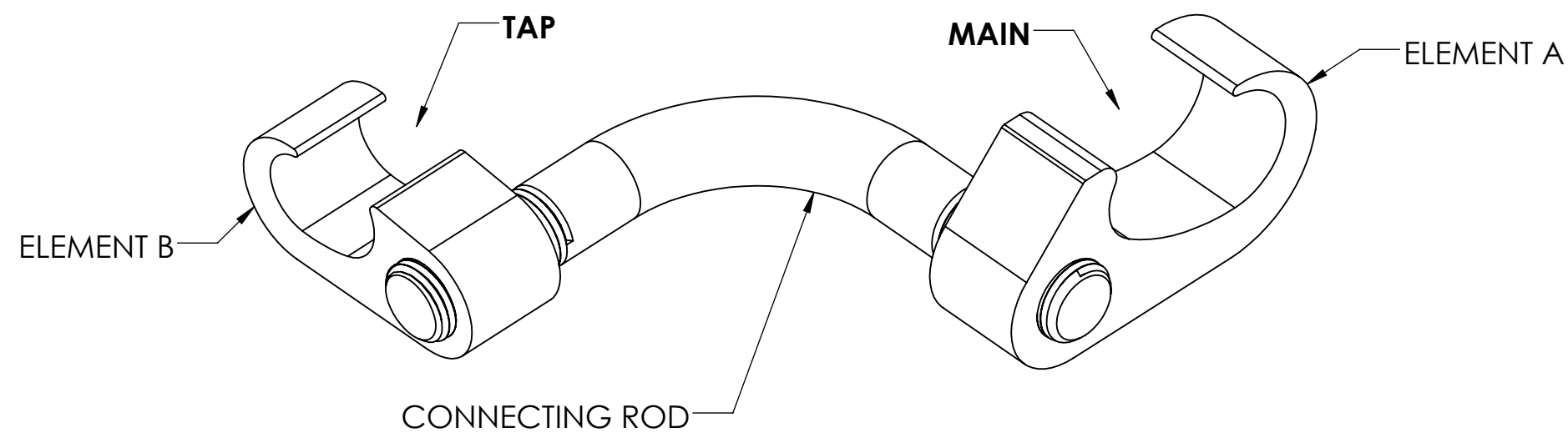

FIGURE 4



PANDUIT PART NUMBER	MAIN - AWG (METRIC)			TAP - AWG (METRIC)	ASSEMBLY			PANDUIT DIE COLOR CODE & INDEX (QTY OF CRIMPS)		STD. PKG. QTY.		
	COPPER CABLE	GROUND ROD	REBAR		ELEMENT A	ELEMENT B	CONNECTING ROD SIZE	ELEMENT A	ELEMENT B			
GCC6-2-2	SOLID: 6 AWG - 2 AWG STRANDED: 6 AWG - 2 AWG (16-25 sq mm)	N/A	N/A	SOLID: 6 AWG - 2 AWG STRANDED: 6 AWG - 2 AWG (16-25 sq mm)	FIGURE 1	FIGURE 1	3/8" ROD	RED PG10 (1)	RED PG10 (1)	1		
GCC6-250-2	SOLID: N/A STRANDED: 2 AWG - 250 kcmil (35-120 sq mm)	1/2" - 5/8" ROD (12.7 - 15.9mm) ROD TYPES: COPPER CLAD SOLID COPPER STAINLESS STEEL	3/8" - 1/2"; #3-#4 REBAR (9.5-12.7mm, #10M-#13M REBAR)	SOLID: 6 AWG - 2 AWG STRANDED: 6 AWG - 2 AWG (16-25 sq mm)	FIGURE 2	FIGURE 1	3/8" ROD	BLACK PG25 (1)	RED PG10 (1)	1		
GCC6-250-250				SOLID: N/A STRANDED: 2 AWG - 250 kcmil (35-120 sq mm)					FIGURE 2		9/16" ROD	BLACK PG25 (1)
GCC6-500-2	SOLID: N/A STRANDED: 250-500 kcmil (150-240 sq mm)	5/8" - 3/4" ROD (15.9 - 19.1mm) ROD TYPES: COPPER CLAD SOLID COPPER STAINLESS STEEL	5/8" - 3/4"; #5-#6 REBAR (15.9-19.1mm, #16M-#19M REBAR)	SOLID: 6 AWG - 2 AWG STRANDED: 6 AWG - 2 AWG (16-25 sq mm)	FIGURE 3	FIGURE 1	3/8" ROD	BLUE PG50 (1)	RED PG10 (1)	1		
GCC6-500-250				SOLID: N/A STRANDED: 2 AWG - 250 kcmil (35-120 sq mm)					FIGURE 2		9/16" ROD	BLACK PG25 (1)
GCC6-500-500				SOLID: N/A STRANDED: 250 - 500 kcmil (150-240 sq mm)								FIGURE 4

NOTES:

- DIMENSIONS IN PARENTHESIS ARE MILLIMETERS.
- ALL PARTS ARE cULus LISTED FOR UL 467 FOR GROUNDING APPLICATIONS AND ARE SUITABLE FOR DIRECT BURIAL IN EARTH OR CONCRETE.
- ALL PARTS ARE cULus LISTED FOR UL 486A/B POWER CONNECTOR APPLICATIONS. (NOTE: WIRE-TO-WIRE COMBINATIONS ONLY)
- PRE-APPLIED ANTIOXIDANT COMPOUND ENSURES A HIGH QUALITY MECHANICAL AND ELECTRICAL BOND, SPEEDING INSTALLATION.



REV	DATE	BY	CHK	APR	DESCRIPTION	ECN
02	1/19	DAOS	JHNU	RGB	REVISED METRIC WIRE RANGE	
01	12/18	DAOS	JHNU	RGB	ADDED CLARITY TO NOTES 2 & 3, ADDED ROD TYPES TO TABLE	
00	7/18	DAOS	JHNU	RGB	DRAWING RELEASED	

TITLE		FIGURE 6 TO 6 SERIES COPPER COMPRESSION GROUNDING TAP CONNECTORS			
ITEM REVISION NAME		00195EAB/02			
DATASET FILE NAME		00195EAB-DC/02.SLDDRW			
UNLESS OTHERWISE SPECIFIED, DIMENSIONAL TOLERANCES ARE: IN [mm]		.X ± .XXX ± .XX ± ANGLES ±			
THIRD ANGLE PROJECTION		DRAWING NUMBER 00195EAB-DC			
DRAWN BY	DATE	CHK	SCALE	SHEET 1 OF 1	
DAOS	7/5/18	JHNU	N/A	C	