

THIS COPY IS PROVIDED ON A RESTRICTED BASIS AND IS NOT TO BE USED IN ANY WAY DETRIMENTAL TO THE INTERESTS OF PANDUIT CORP.

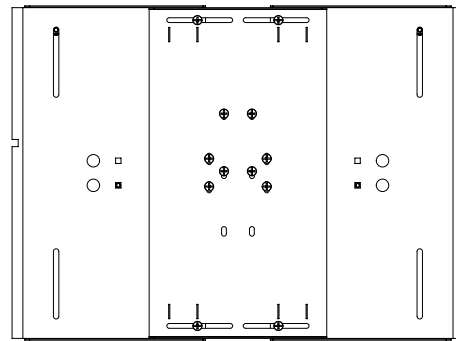

R2P6S
RACK CONFIGURATION

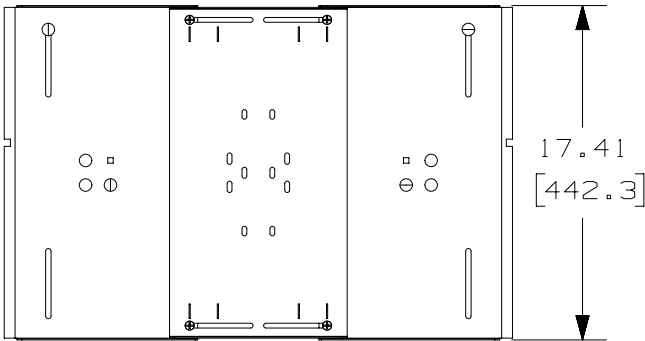
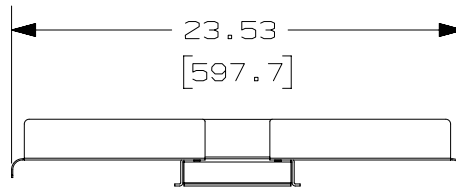
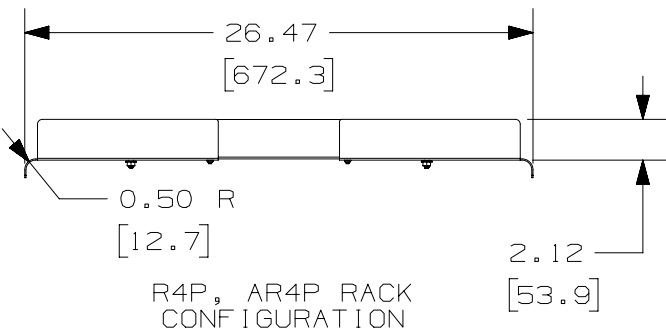

R2P RACK
CONF IGURATION

- NOTES:
1. VISIT OUR ON-LINE CATALOG AT WWW.PANDUIT.COM FOR A LIST OF CURRENT PARTS APPLICABLE FOR USE WITH THIS PRODUCT.
 2. DIMENSIONS IN () ARE METRIC.
 3. WEIGHT: 12.7 lbs [5.8 kg]
 4. PART INCLUDES:
 - 1- ADJUSTABLE WIDTH WATERFALL ASSY
 - 1- R2P RACK MOUNT BRACKET
 - 4- M6x1.0 CARRIAGE BOLTS
 - 4- M6x1.0 SERRATED HEX NUTS
 - 4- M6x1.0 PAN HEAD MACHINE SCREWS

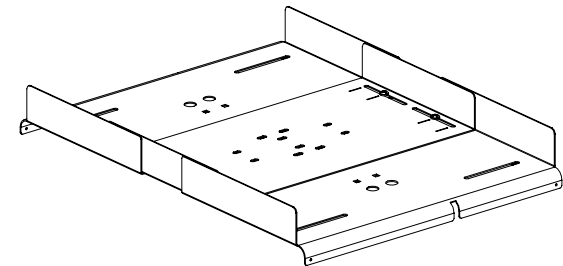

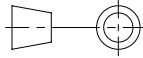
PART NUMBER		PR2VWF, PR2VFWH		
TITLE		ADJUSTABLE WIDTH WATERFALL FOR USE WITH PR2V* VERTICAL CABLE MANAGERS		
		CUSTOMER DRAWING		
ITEM REVISION NAME		00072GEA/01		
DATASET FILE NAME		00072GEA_DC/01A		
		THIRD ANGLE PROJECTION		
MATERIAL		STEEL		
		DRAWING NUMBER		
		00072GEA-DC		
00A	3-19-19	BAME	ENG	PM
RELEASED TO PRODUCTION				
M09000JK				
REV	DATE	BY	CHK	APR
DESCRIPTION				
ECN				
DRAWN BY		DATE		CHK
BAME		3-19-19		KRKE
SCALE		NONE		
SHEET 1 OF 3				SIZE
				A

A-SIZE CUSTOMER

THIS COPY IS PROVIDED ON A RESTRICTED BASIS AND IS NOT TO BE USED IN ANY WAY DETRIMENTAL TO THE INTERESTS OF PANDUIT CORP.

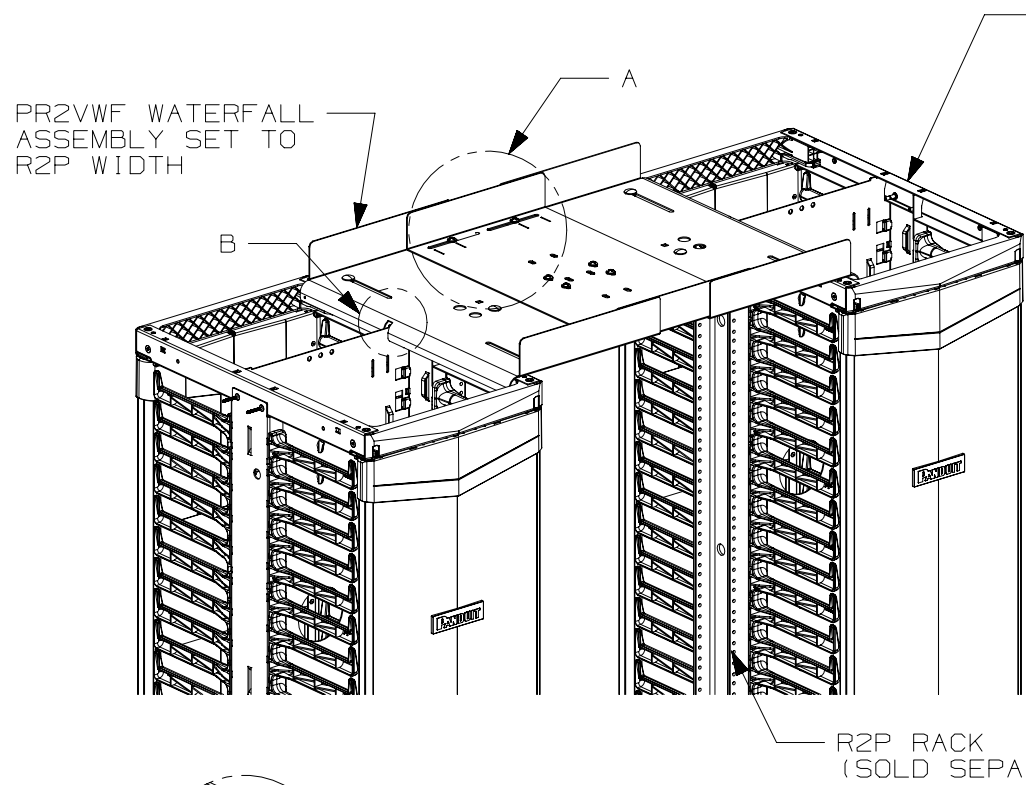

PR2V* VERTICAL CABLE MANAGER (SOLD SEPARATELY)

CORRECT WIDTH FOR USE WITH AN R2P RACK IS ADJUSTED BY LOOSENING THE SET SCREWS AND SLIDING TO ALIGN WITH THE INNER NOTCHES AS SHOWN

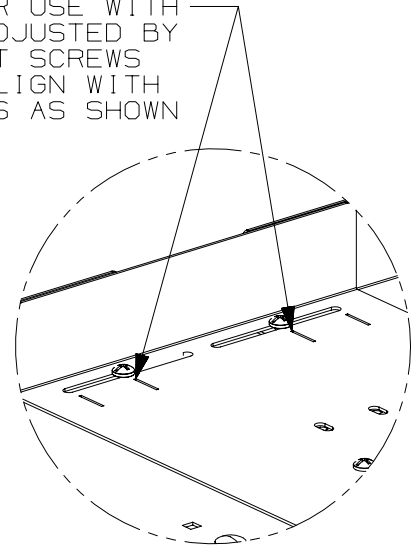

DETAIL A SCALE 1:4

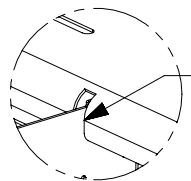

BEND RADIUS FEATURE NOTCHED TO CLEAR THE PR2V CABLE MANAGER BACKBONE. THE WATERFALL CAN BE REVERSED IF THE PE2V CABLE MANAGER IS INSTALLED WITH THE 40% CABLE AREA SET TO THE FRONT OF THE RACK

DETAIL B SCALE 1:4

R2P RACK CONFIGURATION

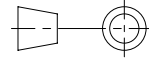
PART NUMBER		PR2VWF, PR2VFWH		
TITLE		ADJUSTABLE WIDTH WATERFALL FOR USE WITH PR2V* VERTICAL CABLE MANAGERS		
		CUSTOMER DRAWING		
ITEM REVISION NAME		00072GEA/01		
DATASET FILE NAME		00072GEA_DC/01A		
		THIRD ANGLE PROJECTION		
MATERIAL		STEEL		DRAWING NUMBER
				00072GEA-DC
DRAWN BY	DATE	CHK	SCALE	SIZE
BAME	3-19-19	KRKE	NONE	A
SHEET 2 OF 3				

A-SIZE CUSTOMER

REV	DATE	BY	CHK	APR	DESCRIPTION	ECN
01A	3-17-23	TWV	KRKE	KCOR	SEE SHEET ONE FOR REVISIONS	M09000JK
00A	3-19-19	BAME			SEE SHEET ONE FOR REVISIONS	M09000JK

THIS COPY IS PROVIDED ON A RESTRICTED BASIS AND IS NOT TO BE USED IN ANY WAY DETRIMENTAL TO THE INTERESTS OF PANDUIT CORP.

PR2VWF WATERFALL ASSEMBLY SET TO R4P, AR4P WIDTH

PR2V* VERTICAL CABLE MANAGER (SOLD SEPARATELY)

CORRECT WIDTH FOR USE WITH AN R4P, AR4P RACK IS ADJUSTED BY LOOSENING THE SET SCREWS AND SLIDING TO ALIGN WITH THE OUTER NOTCHES AS SHOWN

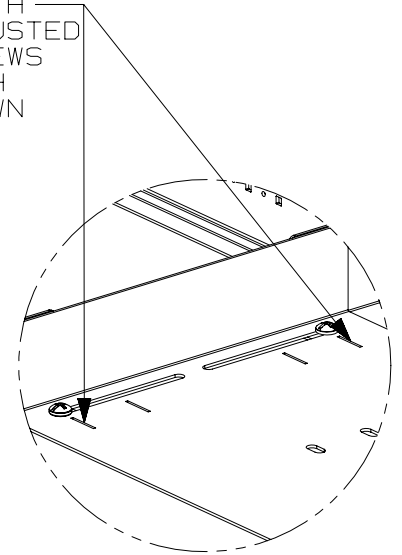
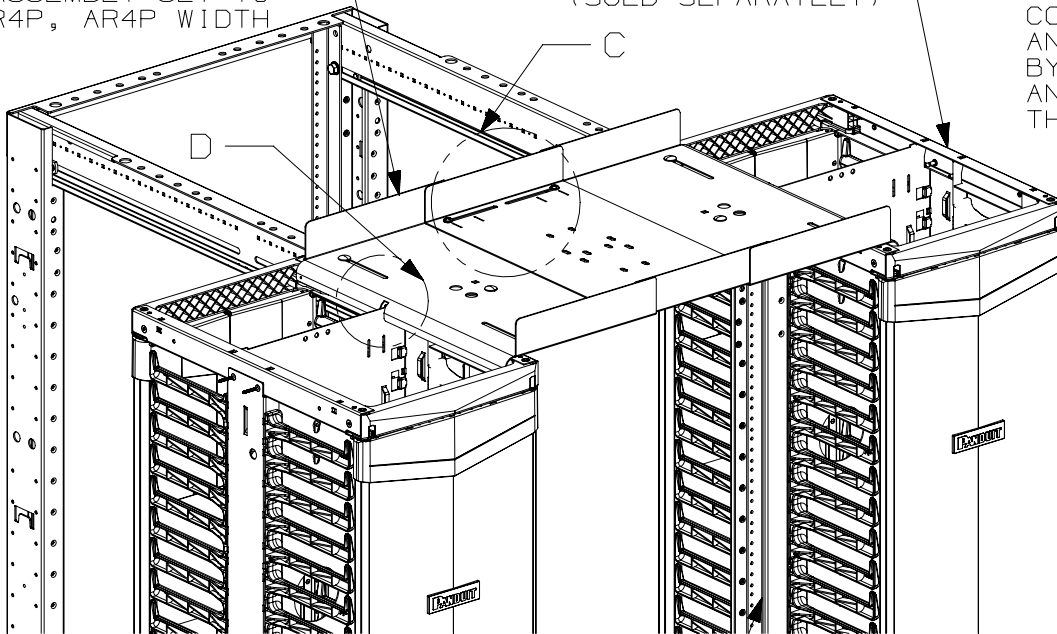

DETAIL C
SCALE 1:4

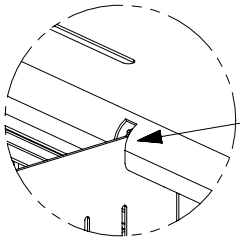

BEND RADIUS FEATURE NOTCHED TO CLEAR THE PR2V CABLE MANAGER BACKBONE. THE WATERFALL CAN BE REVERSED IF THE PR2V CABLE MANAGER IS INSTALLED WITH THE 40% CABLE AREA SET TO THE FRONT OF THE RACK

DETAIL D
SCALE 1:4

R4P, AR4P RACK (SOLD SEPARATELY)

R4P, AR4P RACK CONFIGURATION

PART NUMBER		PR2VWF, PR2VFWH		
TITLE		ADJUSTABLE WIDTH WATERFALL FOR USE WITH PR2V* VERTICAL CABLE MANAGERS		
		CUSTOMER DRAWING		
ITEM REVISION NAME		00072GEA/01		
DATASET FILE NAME		00072GEA_DC/01A		
MATERIAL		STEEL		
DRAWN BY		DATE	CHK	SCALE
BAME		3-19-19	KRKE	NONE
DRAWING NUMBER		00072GEA-DC		
REV		DATE	BY	CHK
00A		3-19-19	BAME	
DESCRIPTION		SEE SHEET ONE FOR REVISIONS		
ECN		M09000JK		
SHEET 3 OF 3		A		

A-SIZE CUSTOMER