

THIS COPY IS PROVIDED ON A RESTRICTED BASIS AND IS NOT TO BE USED IN ANY WAY DETRIMENTAL TO THE INTERESTS OF PANDUIT CORP.

NOTES:

1. VISIT OUR ON-LINE CATALOG AT WWW.PANDUIT.COM FOR A LIST OF CURRENT PARTS APPLICABLE FOR USE WITH THIS PRODUCT AND INSTRUCTION SHEET (V00028CA).
2. DIMENSIONS IN PARENTHESES ARE METRIC [mm].
3. CAN BE USED WITH ANY 19" CEA STANDARD PANEL.
4. PARTS SUPPLIED:
 - 26RU DUAL HINGE NEMA 4/12 ENCLOSURE
 - KEYLOCKING WING KNOBS ARE INCLUDED PROVIDING ACCESS CONTROL TO THE ENCLOSURE. (2) KEYS ARE INCLUDED WITH EACH ENCLOSURE.
 - ACCOMODATIONS FOR AN OPTIONAL AIR CONDITIONER.
 - RAL 7035 LIGHT-GRAY, LOW GLOSS, LIGHTLY TEXTURED POLYESTER POWDER COAT
 - INSTALLED FRONT AND REAR CAGE NUT RAILS IN OPTIMIZED POSITIONS FOR EQUIPMENT MOUNTING.
 - INSTALLED POWER RECEPTACLE
 - INSTALLED FIBER ENCLOSURE (72 FIBER CAPACITY)
 - INSTALLED (2) 48-PORT PATCH PANELS
 - INSTALLED CABLE MANAGEMENT
 - INSTALLED DOOR GROUND WHIPS, EQUIPMENT GROUND WHIPS (ONE END)
 - INSTALLED GROUND BAR
 - INFRASTRUCTURE GROUND CABLE
 - POWER CORDS, LABELED AND LENGTH OPTIMIZED
 - 10" LONG DIN RAIL MOUNTING PROVISION
 - CABLE/FIBER/POWER PENETRATION RECOMMENDATION TEMPLATE
 - INSTRUCTIONS FOR CABLE ROUTING AND MANAGEMENT
5. CENTER HINGED SECTION
MAXIMUM LOAD RATING: 350 LBS [158.8 kg].

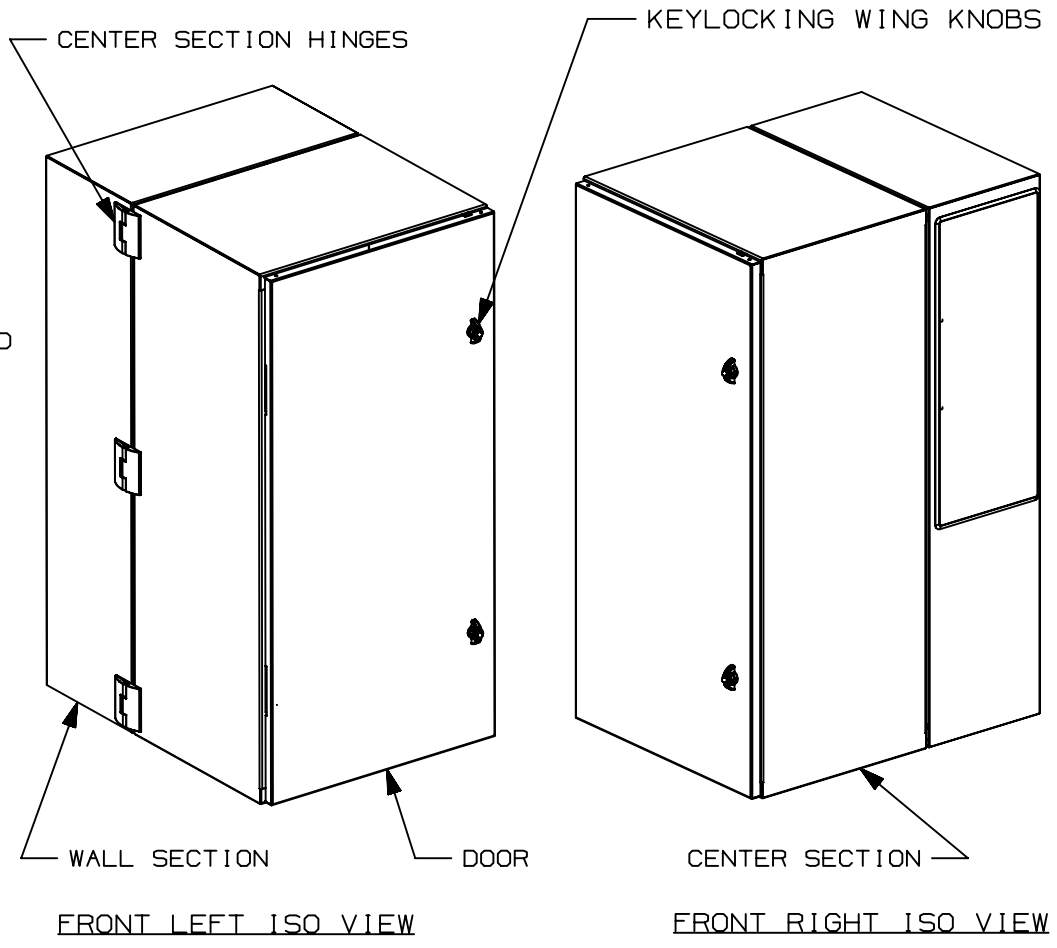

SHIPPING LENGTH	57"
SHIPPING WIDTH	39"
SHIPPING HEIGHT	35-1/4"
SHIPPING WEIGHT	270 lbs. 122.5 kg.
ENCLOSURE WEIGHT	218 lbs. 98.9 kg.

TITLE		ZDF48-RA PRECONFIGURED 48" INDUSTRIAL DISTRIBUTION FRAME	
		CUSTOMER DRAWING	
ITEM REVISION NAME		13V397AD/03	
DATASET FILE NAME		13V397AD_DC_03D	
UNLESS OTHERWISE SPECIFIED, DIMENSIONAL TOLERANCES ARE: IN [mm]		PANDUIT MATERIAL: SEE NOTES DRAWING NUMBER: 13V397AD_DC	
.x ± .1 [2.54] .xxx ± .015 [0.38]			
.xx ± .03 [0.76] ANGLES ± 5 °			
THIRD ANGLE PROJECTION			
DRAWN BY	DATE	CHK	SCALE
DAJP	05/05/2014	NWW	NONE
REV		SHT 1 OF 4	
DATE		SIZE	
BY		A	

03D	4/21/20	JBO	DAJP	KGA	RELEASED TO PRODUCTION	13V397AD
REV	DATE	BY	CHK	APR	DESCRIPTION	ECN

2

1

THIS COPY IS PROVIDED ON A RESTRICTED BASIS AND IS NOT TO BE USED IN ANY WAY DETRIMENTAL TO THE INTERESTS OF PANDUIT CORP.

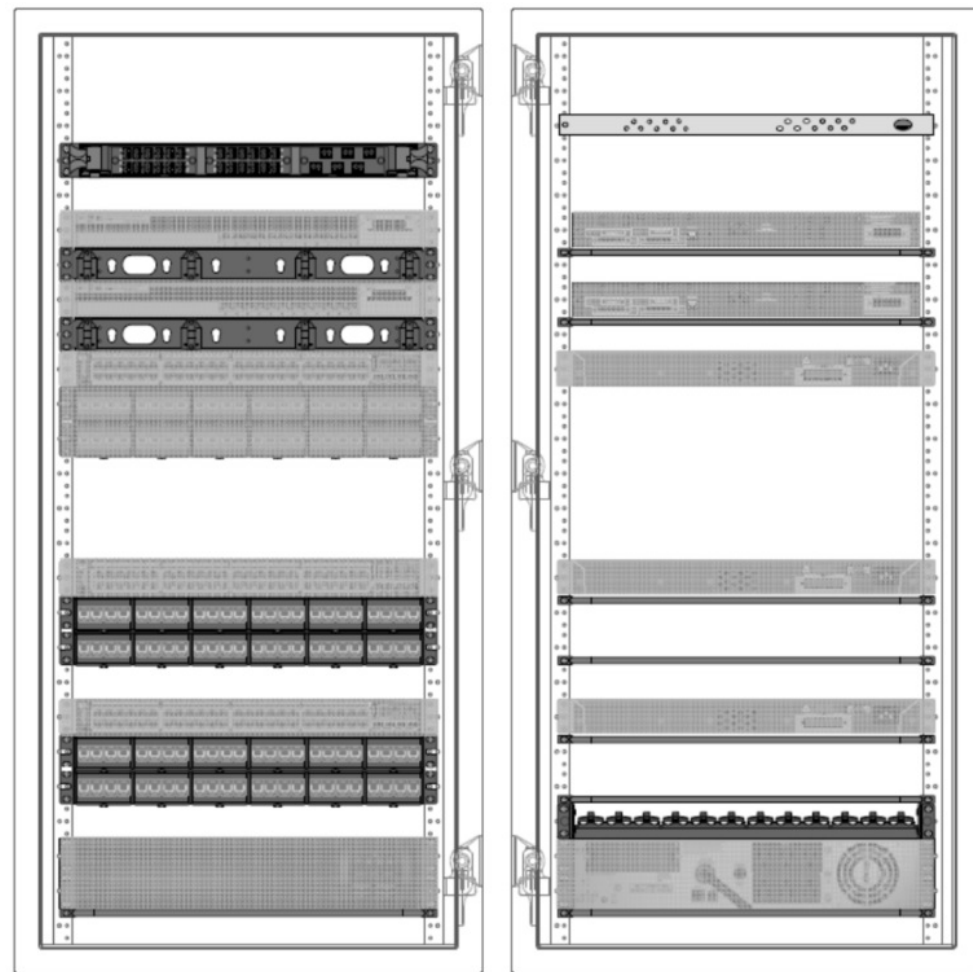

Front View

Back View

- RU 24 PANDUIT RGRB19CN GROUND BAR
- RU 23 PANDUIT FRME1U FIBER ENCLOSURE
- RU 22 OPEN (ADDITIONAL FRME1U IF REQUIRED)
- RU 21 CUSTOMER SWITCH w/ 12 FIBER LS NICs – “B”
- RU 20 PANDUIT CMPHF1 HORIZONTAL CABLE MANGER
- RU 19 CUSTOMER FIBER w/ 12 FIBER LS NICs– “A”
- RU 18 PANDUIT CMPHF1 HORIZONTAL CABLE MANGER
- RU 17 OPTIONAL CUSTOMER SWITCH – “C”
- RU 15-16 OPTIONAL PANDUIT CPP48WBLY 48 PORT COPPER PATCH PANEL

- RU 12-14 OPEN

- RU 11 CUSTOMER SWITCH – “B”
- RU 9-10 PANDUIT CPP48WBLY 48 PORT COPPER PATCH PANEL

- RU 8 OPEN
- RU 7 CUSTOMER SWITCH – “A”
- RU 5-6 PANDUIT CPP48WBLY 48 PORT COPPER PATCH PANEL

- RU 4 PANDUIT SRBBRWC STRAIN RELIEF BAR
- RU 2-3 CUSTOMER UPS

- RU 1 OPEN

TITLE		ZDF48-RA PRECONFIGURED 48" INDUSTRIAL DISTRIBUTION FRAME	
		CUSTOMER DRAWING	
ITEM REVISION NAME		13V397AD/03	
DATASET FILE NAME		13V397AD_DC_03D	
UNLESS OTHERWISE SPECIFIED, DIMENSIONAL TOLERANCES ARE: IN [mm]		PANDUIT	
.x ± .1 [2.54] .xxx ± .015 [0.38] .xx ± .03 [0.76] ANGLES ± 5 °			
DRAWING NUMBER:		SEE SHEET 1 NOTES	
		13V397AD_DC	
DRAWN BY		DATE	
DAJP		05/05/2014	
CHK		SCALE	
NWW		NONE	
THIRD ANGLE PROJECTION		SHT 2 OF 4	
SIZE		A	

03D	4/21/20	JBO	DAJP	KGA	REFER TO SHEET 1 FOR REVISION CONTROL	13V397AD
REV	DATE	BY	CHK	APR	DESCRIPTION	ECN

2

1

THIS COPY IS PROVIDED ON A RESTRICTED BASIS AND IS NOT TO BE USED IN ANY WAY DETRIMENTAL TO THE INTERESTS OF PANDUIT CORP.

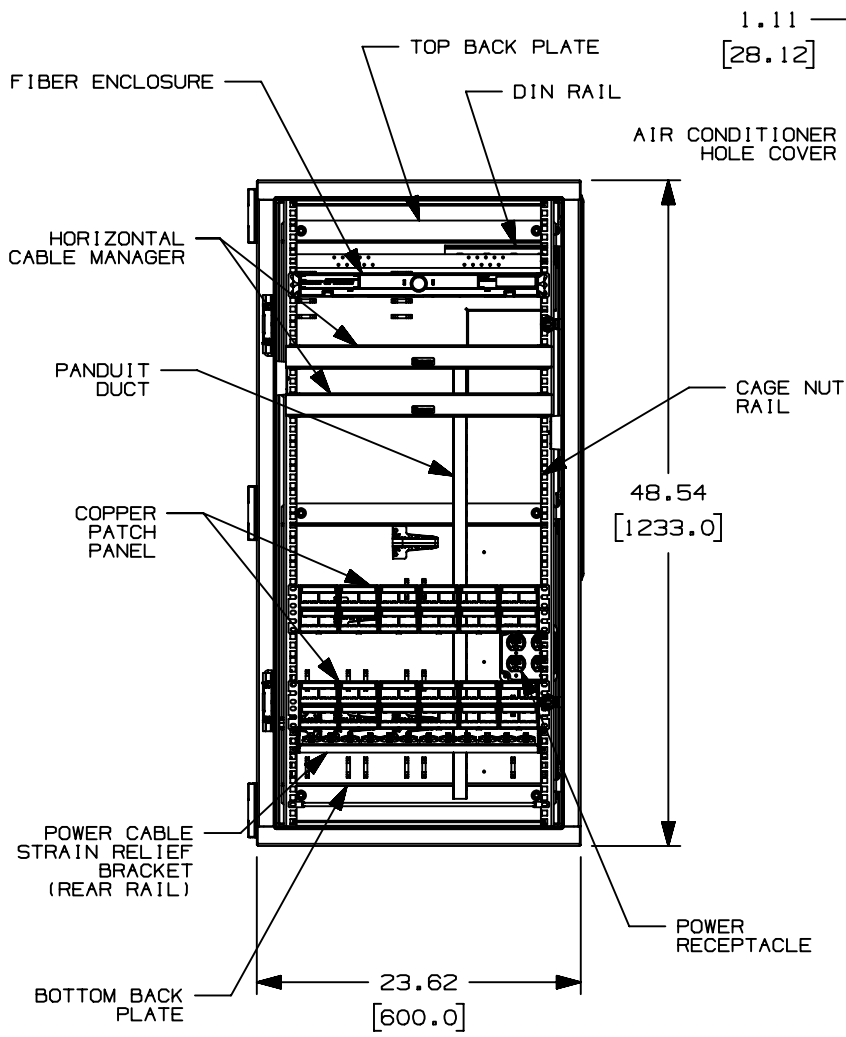

FRONT VIEW
DOOR HIDDEN TO SHOW
INSIDE DETAILS

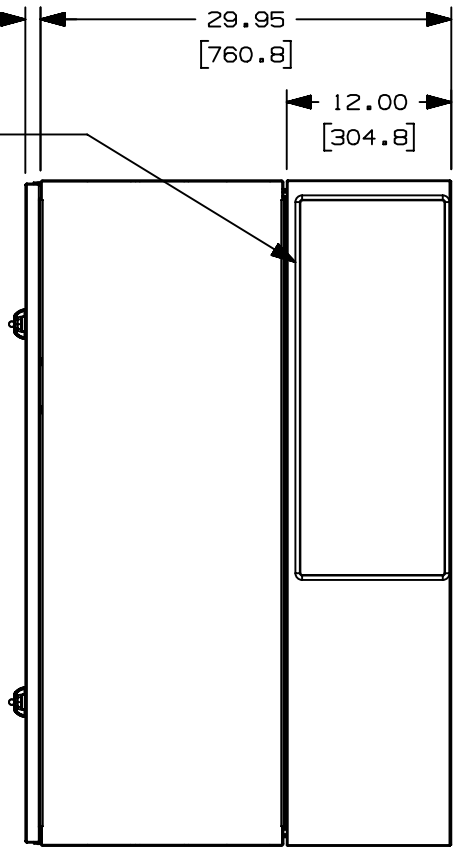

SIDE VIEW

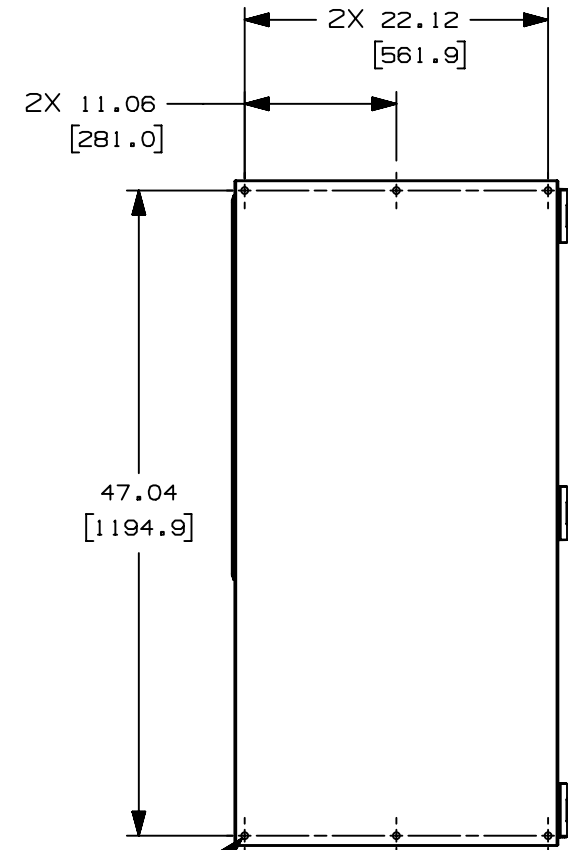

BACK VIEW

6X Ø 0.50
[12.70]
MOUNTING HOLES

TITLE		ZDF48-RA PRECONFIGURED 48" INDUSTRIAL DISTRIBUTION FRAME	
ITEM REVISION NAME		13V397AD/03	
DATASET FILE NAME		13V397AD_DC_03D	
UNLESS OTHERWISE SPECIFIED, DIMENSIONAL TOLERANCES ARE: IN [mm]			
.x ± .1 [2.54] .xxx ± .015 [0.38] .xx ± .03 [0.76] ANGLES ± 5°			
DRAWING NUMBER:		13V397AD_DC	
DRAWN BY		DATE	CHK
DAJP		05/05/2014	NWW
SCALE		NONE	
SHT 3 OF 4		A	

03D	4/21/20	JBO	DAJP	KGA	REFER TO SHEET 1 FOR REVISION CONTROL	13V397AD
REV	DATE	BY	CHK	APR	DESCRIPTION	ECN

THIS COPY IS PROVIDED ON A RESTRICTED BASIS AND IS NOT TO BE USED IN ANY WAY DETRIMENTAL TO THE INTERESTS OF PANDUIT CORP.

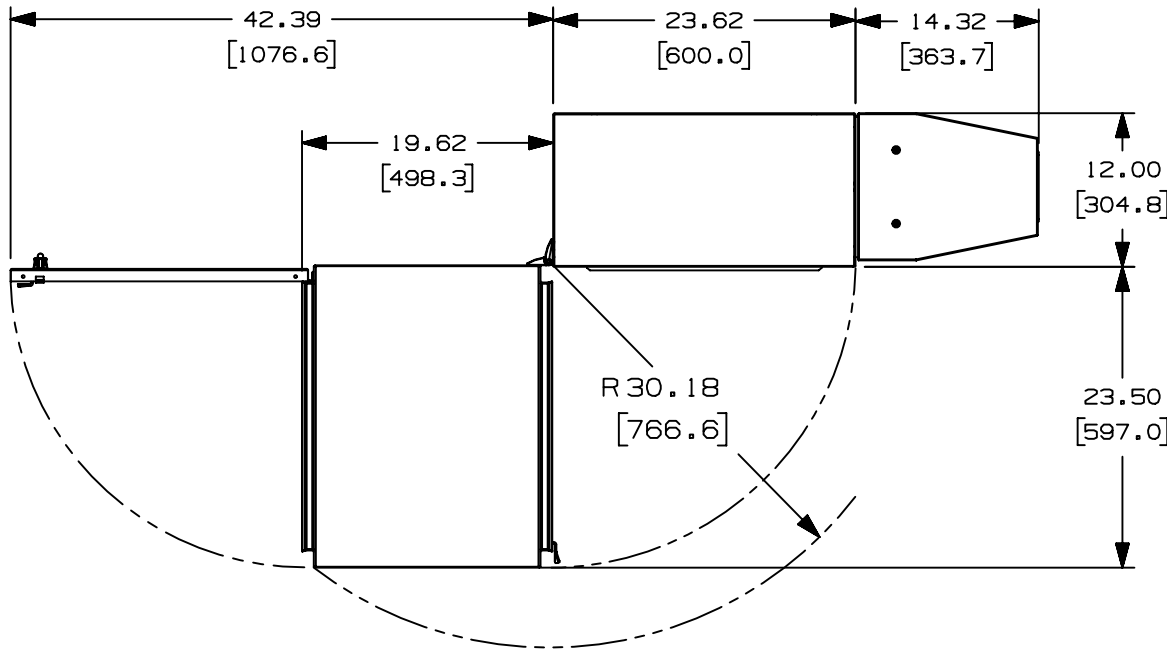

PLAN VIEW SHOWING OPEN ENCLOSURE

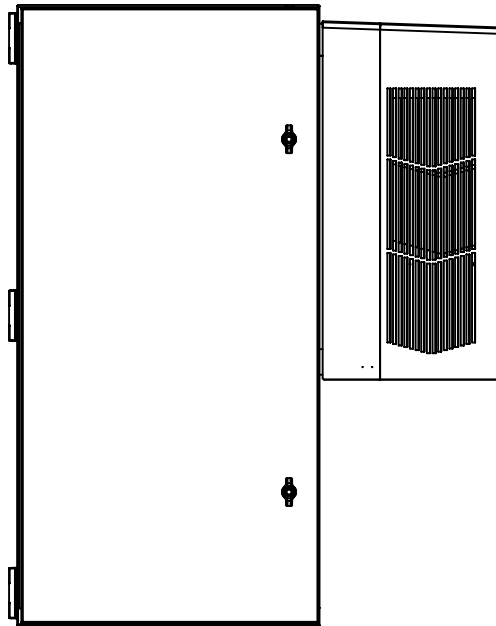

OPTIONAL HOFFMAN N28 MODEL AIR CONDITIONER

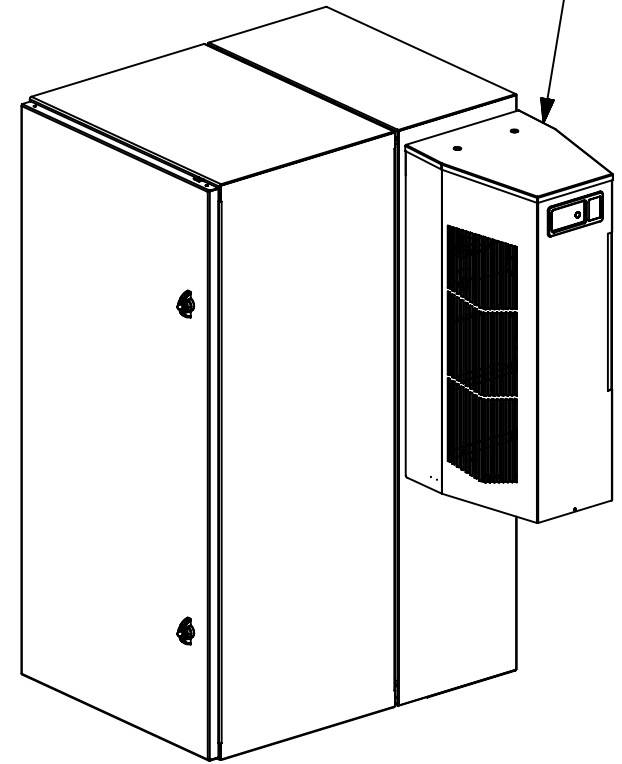

ISOMETRIC VIEW SHOWING OPTIONAL AIR CONDITIONER

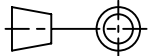
TITLE										
ZDF48-RA PRECONFIGURED 48" INDUSTRIAL DISTRIBUTION FRAME										
CUSTOMER DRAWING										
ITEM REVISION NAME					13V397AD/03					
DATASET FILE NAME					13V397AD_DC_03D					
UNLESS OTHERWISE SPECIFIED, DIMENSIONAL TOLERANCES ARE: IN [mm]										
.x ± .1 [2.54]					.xxx ± .015 [0.38]					
.xx ± .03 [0.76]					ANGLES ± 5 °					
 THIRD ANGLE PROJECTION										
MATERIAL:										
SEE SHEET 1 NOTES										
DRAWING NUMBER:										
13V397AD_DC										
03D	4/21/20	JBO	DAJP	KGA	REFER TO SHEET 1 FOR REVISION CONTROL					13V397AD
REV	DATE	BY	CHK	APR	DESCRIPTION					ECN