

THIS COPY IS PROVIDED ON A RESTRICTED BASIS AND IS NOT TO BE USED IN ANY WAY DETRIMENTAL TO THE INTERESTS OF PANDUIT CORP.

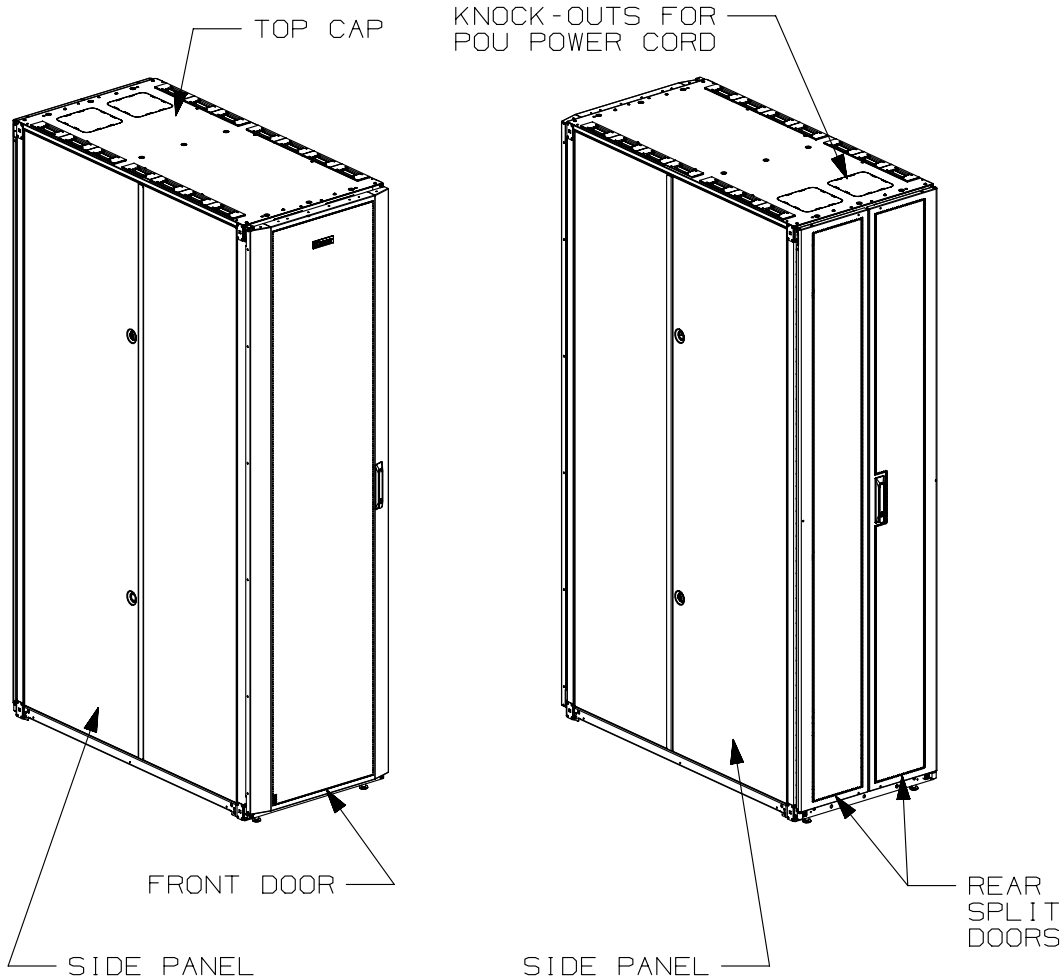

1. VISIT OUR ON-LINE CATALOG AT WWW.PANDUIT.COM FOR A LIST OF CURRENT PARTS APPLICABLE FOR USE WITH THIS PRODUCT.
2. PRIMARY DIMENSIONS ARE IN MILLIMETERS.
3. INDEPENDENT ADJUSTABLE REAR EQUIPMENT MOUNTING RAILS (EIA) ADJUST FROM 65mm TO 532mm AND FROM 583mm TO 919mm WITH POU BRACKETS AND CABLE MANAGEMENT FINGERS IN PLACE. REMOVING POU BRACKETS AND OPTIONAL FINGERS INCREASES MAXIMUM E-RAIL SPAN TO 1065mm.
4. CAN BE USED WITH ANY 19" EIA STANDARD COMPONENT IN ADDITION TO ALL PANDUIT HORIZONTAL CABLE MANAGEMENT AND PATCH PANEL PRODUCTS.
5. EIA UNIVERSAL STANDARD HOLE PROGRESSION ON EQUIPMENT RAILS 15.88mm, 15.88mm, 12.70mm, 15.88mm, 15.88mm, 12.7mm...ETC.
6. PARTS SUPPLIED:
 - BASE CABINET
 - FRONT DOOR (SEE CHART ON SHEET 2)
 - REAR SPLIT DOOR (SEE CHART ON SHEET 2)
 - EQUIPMENT RAILS FRONT & REAR (SEE CHART ON SHEET 2)
 - POU BRACKETS (SEE CHART ON SHEET 2)
 - CASTERS (SEE CHART ON SHEET 2)
 - INSTRUCTION SHEET
7. RACK UNIT SPACING NUMERALS ARE CLEARLY PRINTED ON EQUIPMENT MOUNTING RAILS.
8. FULLY BONDED STRUCTURE WHEN ASSEMBLED PER INSTRUCTIONS.
9. STATIC LOAD RATING. 1360 Kg (3000 LBS)
10. ROLLING LOAD RATING. 1133 Kg (2500 LBS)
11. SINGLE POINT GROUND LOCATIONS AT TOP AND BOTTOM OF CABINET.
12. ALL CABINET RAILS ARE INSTALLED NUMBERS UP.
13. MAXIMUM EQUIPMENT DEPTH, 1111mm(43.75).

TITLE
NET-ACCESS S TYPE CABINET
600mm WIDE X 1200mm DEEP FAMILY
 CUSTOMER DRAWING

ITEM REVISION NAME
 12V305QY/00.PRT

DATASET FILE NAME
 12V305QY_DC/00B.PRT

UNLESS OTHERWISE SPECIFIED, DIMENSIONAL TOLERANCES ARE:

INCHES	METRIC - MILLIMETER	ANGLE
X.X +/- 0.03	X.X +/- 0.8	+/- 1°
X.XX +/- 0.018	X.X +/- 0.46	
X.XXX +/- 0.007	X.XX +/- 0.18	

PANDUITTM

MATERIAL/COLOR:
 N/A



DRAWING NUMBER:
 12V305QY - DC

REV	DATE	BY	CHK	APR	DESCRIPTION	ECN
00B	5-17-13	PBS	JDW	JDWE	REVISED CHART	12V305QY-DC
00A	8-27-12	TKW	JDW	PBD	RELEASED TO PRODUCTION	12V305QY-DC

DRAWN BY	DATE	CHK	SCALE	SIZE
TKW	8-27-12	JDW	NONE	A

SHT 1 OF 5

THIS COPY IS PROVIDED ON A RESTRICTED BASIS AND IS NOT TO BE USED IN ANY WAY DETRIMENTAL TO THE INTERESTS OF PANDUIT CORP.

PART NO.	DESCRIPTION	SINGLE HINGE FRONT DOOR	SPLIT REAR DOOR	SPLIT SIDE PANEL	FRONT CAGE NUT E-RAIL	REAR CAGE NUT FINGER MGMT E-RAIL	REAR CAGE NUT VERTICAL PATCH E-RAIL	STANDARD PDU BRACKETS	CASTERS	CABLE MGMT FINGERS	CABINET WEIGHT FULLY UNPACKAGED	CABINET WEIGHT SHIPPING WEIGHT
S6222*	NET-ACCESS S-TYPE CABINET 600mm X 42RU X 1200mm DEEP	01	01	02	02	02	00	02	04	00	128 Kg/EACH 282 LBS/EACH	148 Kg/EACH 327 LBS/EACH
S6522*	NET-ACCESS S-TYPE CABINET 600mm X 45RU X 1200mm DEEP	01	01	02	02	02	00	02	04	00	132 Kg/EACH 292 LBS/EACH	153 Kg/EACH 337 LBS/EACH
S6822*	NET-ACCESS S-TYPE CABINET 600mm X 48RU X 1200mm DEEP	01	01	02	02	02	00	02	04	00	137 Kg/EACH 302 LBS/EACH	157 Kg/EACH 347 LBS/EACH
S6229*	NET-ACCESS S-TYPE CABINET 600mm X 42RU X 1200mm DEEP	01	01	00	02	02	00	02	04	00	92 Kg/EACH 202 LBS/EACH	112 Kg/EACH 247 LBS/EACH
S6529*	NET-ACCESS S-TYPE CABINET 600mm X 45RU X 1200mm DEEP	01	01	00	02	02	00	02	04	00	94 Kg/EACH 207 LBS/EACH	114 Kg/EACH 252 LBS/EACH
S6829*	NET-ACCESS S-TYPE CABINET 600mm X 48RU X 1200mm DEEP	01	01	00	02	02	00	02	04	00	96 Kg/EACH 212 LBS/EACH	116 Kg/EACH 257 LBS/EACH
S6222*F	NET-ACCESS S-TYPE CABINET 600mm X 42RU X 1200mm DEEP	01	01	02	02	02	00	02	04	01	129 Kg/EACH 284 LBS/EACH	149 Kg/EACH 329 LBS/EACH
S6522*F	NET-ACCESS S-TYPE CABINET 600mm X 45RU X 1200mm DEEP	01	01	02	02	02	00	02	04	01	133 Kg/EACH 294 LBS/EACH	154 Kg/EACH 339 LBS/EACH
S6822*F	NET-ACCESS S-TYPE CABINET 600mm X 48RU X 1200mm DEEP	01	01	02	02	02	00	02	04	01	138 Kg/EACH 304 LBS/EACH	158 Kg/EACH 349 LBS/EACH
S6229*F	NET-ACCESS S-TYPE CABINET 600mm X 42RU X 1200mm DEEP	01	01	00	02	02	00	02	04	01	92 Kg/EACH 204 LBS/EACH	113 Kg/EACH 249 LBS/EACH
S6529*F	NET-ACCESS S-TYPE CABINET 600mm X 45RU X 1200mm DEEP	01	01	00	02	02	00	02	04	01	95 Kg/EACH 209 LBS/EACH	115 Kg/EACH 254 LBS/EACH
S6829*F	NET-ACCESS S-TYPE CABINET 600mm X 48RU X 1200mm DEEP	01	01	00	02	02	00	02	04	01	97 Kg/EACH 214 LBS/EACH	117 Kg/EACH 259 LBS/EACH
S6222*S	NET-ACCESS S-TYPE CABINET 600mm X 42RU X 1200mm DEEP	00	00	02	02	02	00	02	04	00	103 Kg/EACH 227 LBS/EACH	123 Kg/EACH 272 LBS/EACH
S6522*S	NET-ACCESS S-TYPE CABINET 600mm X 45RU X 1200mm DEEP	00	00	02	02	02	00	02	04	00	107 Kg/EACH 237 LBS/EACH	128 Kg/EACH 282 LBS/EACH
S6822*S	NET-ACCESS S-TYPE CABINET 600mm X 48RU X 1200mm DEEP	00	00	02	02	02	00	02	04	00	112 Kg/EACH 247 LBS/EACH	132 Kg/EACH 292 LBS/EACH
S6229*S	NET-ACCESS S-TYPE CABINET 600mm X 42RU X 1200mm DEEP	00	00	00	02	02	00	02	04	00	67 Kg/EACH 147 LBS/EACH	87 Kg/EACH 192 LBS/EACH
S6529*S	NET-ACCESS S-TYPE CABINET 600mm X 45RU X 1200mm DEEP	00	00	00	02	02	00	02	04	00	69 Kg/EACH 152 LBS/EACH	89 Kg/EACH 197 LBS/EACH
S6829*S	NET-ACCESS S-TYPE CABINET 600mm X 48RU X 1200mm DEEP	00	00	00	02	02	00	02	04	00	71 Kg/EACH 157 LBS/EACH	92 Kg/EACH 202 LBS/EACH

* DENOTES COLOR

"B" = BLACK

"W" = WHITE

						TITLE NET-ACCESS S TYPE CABINET 600mm WIDE X 1200mm DEEP FAMILY CUSTOMER DRAWING									
						ITEM REVISION NAME 12V305QY/00.PRT				PANDUIT TM					
						DATASET FILE NAME 12V305QY_DC/00B.PRT									
						UNLESS OTHERWISE SPECIFIED, DIMENSIONAL TOLERANCES ARE:									
						INCHES X.X +/- 0.03 X.XX +/- 0.018 X.XXX +/- 0.007		METRIC - MILLIMETER X.X +/- 0.8 X.X +/- 0.46 X.XX +/- 0.18		ANGLE +/- 1°					
						DRAWING NUMBER: 12V305QY-DC				MATERIAL/COLOR: N/A					
						DRAWN BY TKW				DATE 8-27-12		CHK JDW		SCALE NONE	
REV						DESCRIPTION						SHT 2 OF 5		SIZE A	
00B						5-17-13 PBS JDW JDWE SEE SHEET 1 OF 5 FOR REVISIONS						12V305QY-DC			
00A						8-27-12 TKW JDW PBD SEE SHEET 1 OF 5 FOR REVISIONS						12V305QY-DC			

THIS COPY IS PROVIDED ON A RESTRICTED BASIS AND IS NOT TO BE USED IN ANY WAY DETRIMENTAL TO THE INTERESTS OF PANDUIT CORP.

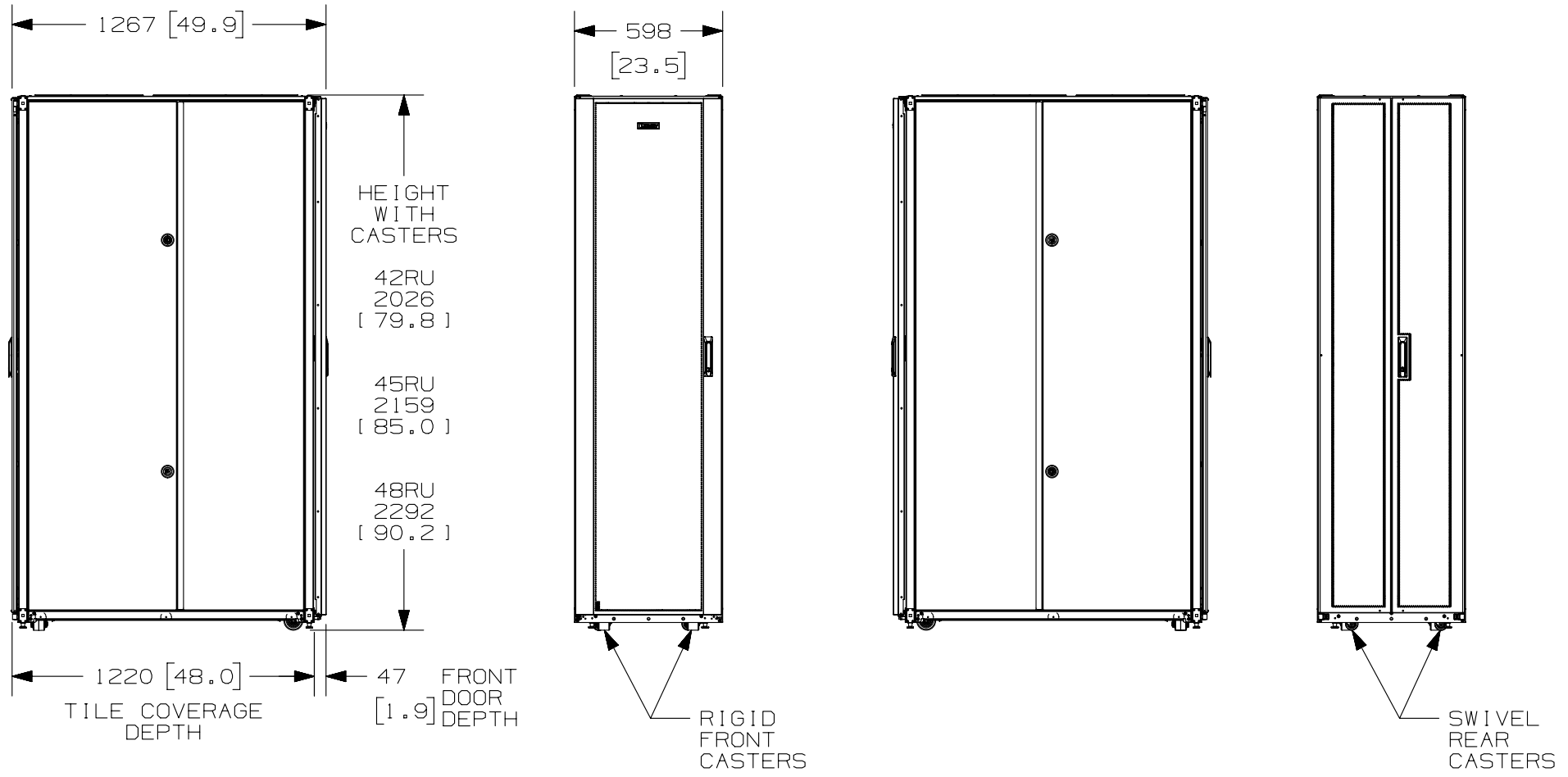

00B	5-17-13	PBS	JDW	JDWE	SEE SHEET 1 OF 5 FOR REVISIONS	12V305QY-DC
00A	8-27-12	TKW	JDW	PBD	SEE SHEET 1 OF 5 FOR REVISIONS	12V305QY-DC
REV	DATE	BY	CHK	APR	DESCRIPTION	ECN

TITLE NET-ACCESS S TYPE CABINET 600mm WIDE X 1200mm DEEP FAMILY CUSTOMER DRAWING		
ITEM REVISION NAME 12V305QY/00.PRT		PANDUIT TM
DATASET FILE NAME 12V305QY_DC/00B.PRT		
UNLESS OTHERWISE SPECIFIED, DIMENSIONAL TOLERANCES ARE:		MATERIAL/COLOR: N/A
INCHES X.X +/- 0.03 X.XX +/- 0.018 X.XXX +/- 0.007	METRIC - MILLIMETER X.X +/- 0.8 X.X +/- 0.46 X.XX +/- 0.18	ANGLE +/- 1°
DRAWN BY: TKW DATE: 8-27-12		DRAWING NUMBER: 12V305QY-DC
CHK: JDW	SCALE: NONE	SIZE: A

THIS COPY IS PROVIDED ON A RESTRICTED BASIS AND IS NOT TO BE USED IN ANY WAY DETRIMENTAL TO THE INTERESTS OF PANDUIT CORP.

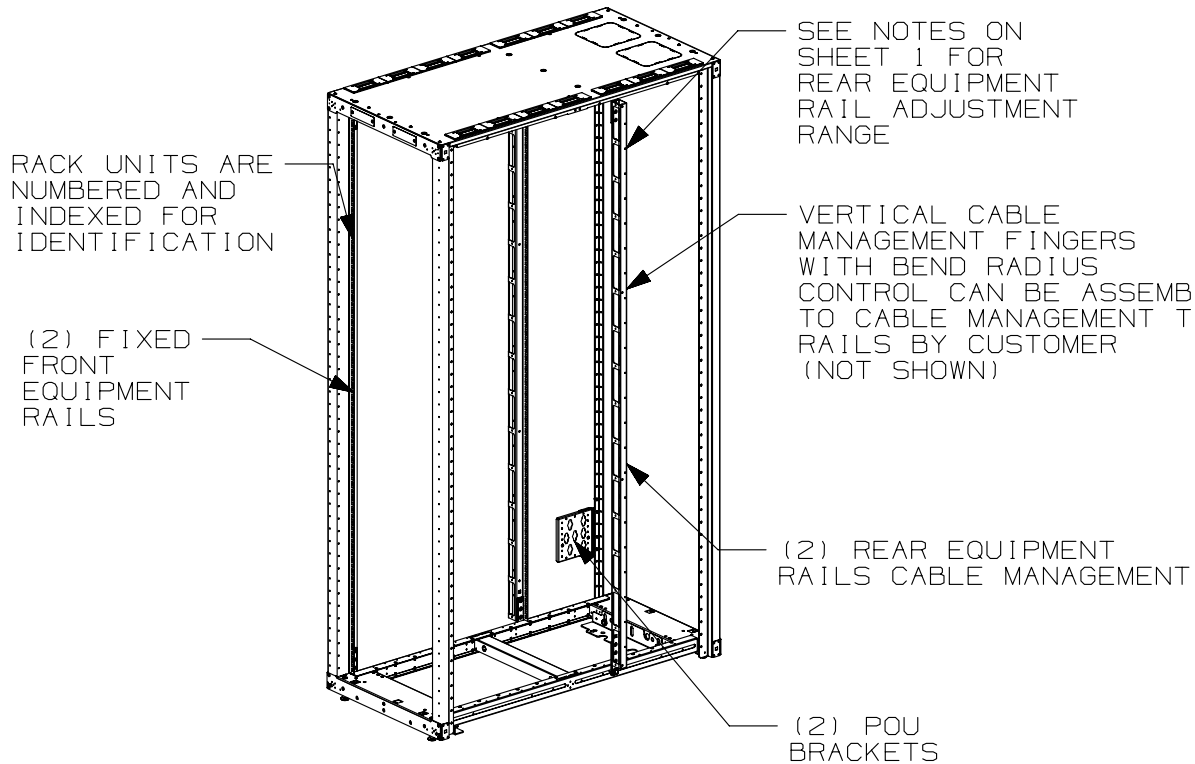

FRONT DOOR, REAR DOOR, AND SIDE PANELS NOT SHOWN

(9) LOCATIONS TAPPED FOR M10 THREADED ROD

(2) 165mm X 165mm KNOCKOUTS FOR POU POWER CORDS COMPATIBLE W/COOL BOOT P/N: CTGN6X6

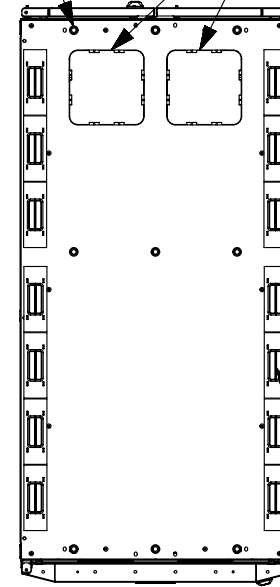

TOP VIEW

REV	DATE	BY	CHK	APR	DESCRIPTION	ECN
00B	5-17-13	PBS	JDW	JDWE	SEE SHEET 1 OF 5 FOR REVISIONS	12V305QY-DC
00A	8-27-12	TKW	JDW	PBD	SEE SHEET 1 OF 5 FOR REVISIONS	12V305QY-DC

TITLE		NET-ACCESS S TYPE CABINET 600mm WIDE X 1200mm DEEP FAMILY		
		CUSTOMER DRAWING		
ITEM REVISION NAME		12V305QY/00.PRT		
DATASET FILE NAME		12V305QY_DC/00B.PRT		
UNLESS OTHERWISE SPECIFIED, DIMENSIONAL TOLERANCES ARE:		MATERIAL/COLOR:		
INCHES	METRIC - MILLIMETER	ANGLE		
X.X +/- 0.03	X +/- 0.8	N/A		
X.XX +/- 0.018	X.X +/- 0.46			
X.XXX +/- 0.007	X.XX +/- 0.18			
DRAWING NUMBER:		12V305QY-DC		
DRAWN BY	DATE	CHK	SCALE	SIZE
TKW	8-27-12	JDW	NONE	A

THIS COPY IS PROVIDED ON A RESTRICTED BASIS AND IS NOT TO BE USED IN ANY WAY DETRIMENTAL TO THE INTERESTS OF PANDUIT CORP.

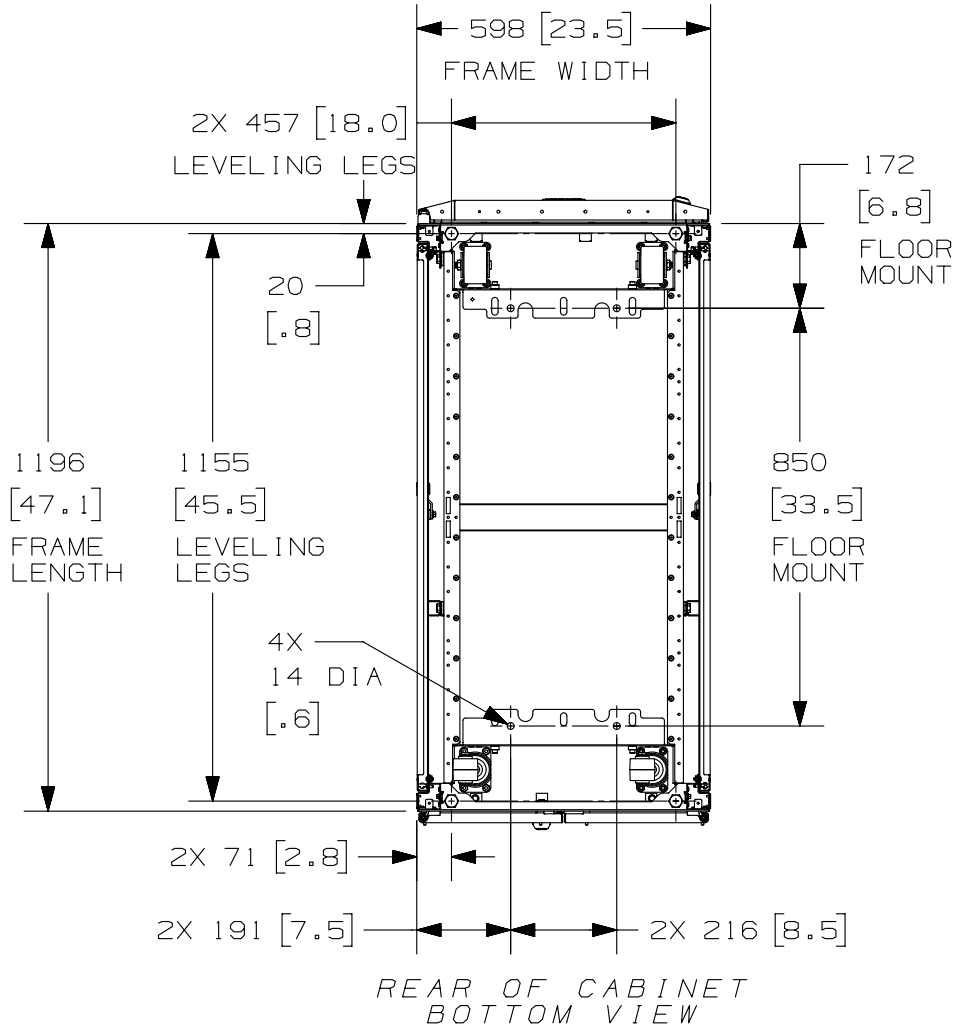

FLOOR MOUNTING HOLE LOCATIONS - SOME PARTS REMOVED FOR CLARITY

REV	DATE	BY	CHK	APR	DESCRIPTION	ECN
00B	5-17-13	PBS	JDW	JDWE	SEE SHEET 1 OF 5 FOR REVISIONS	12V305QY-DC
00A	8-27-12	TKW	JDW	PBD	SEE SHEET 1 OF 5 FOR REVISIONS	12V305QY-DC

TITLE		NET-ACCESS S TYPE CABINET 600mm WIDE X 1200mm DEEP FAMILY	
		CUSTOMER DRAWING	
ITEM REVISION NAME		12V305QY/00.PRT	
DATASET FILE NAME		12V305QY_DC/00B.PRT	
UNLESS OTHERWISE SPECIFIED, DIMENSIONAL TOLERANCES ARE:		MATERIAL/COLOR:	
INCHES	METRIC - MILLIMETER	N/A	
X.X +/- 0.03	X.X +/- 0.8		
X.XX +/- 0.018	X.X +/- 0.46		
X.XXX +/- 0.007	X.XX +/- 0.18		
THIRD ANGLE PROJECTION		DRAWING NUMBER:	
DRAWN BY: TKW		12V305QY-DC	
DATE: 8-27-12		SHT 5 OF 5	
CHK: JDW		SIZE: A	
SCALE: NONE			