

THIS COPY IS PROVIDED ON A RESTRICTED BASIS AND IS NOT TO BE USED IN ANY WAY DETRIMENTAL TO THE INTERESTS OF PANDUIT CORP.

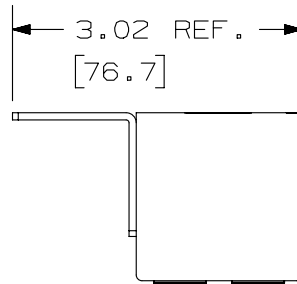
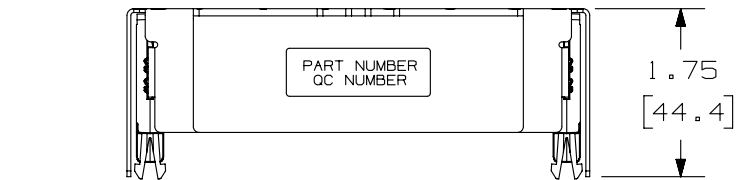
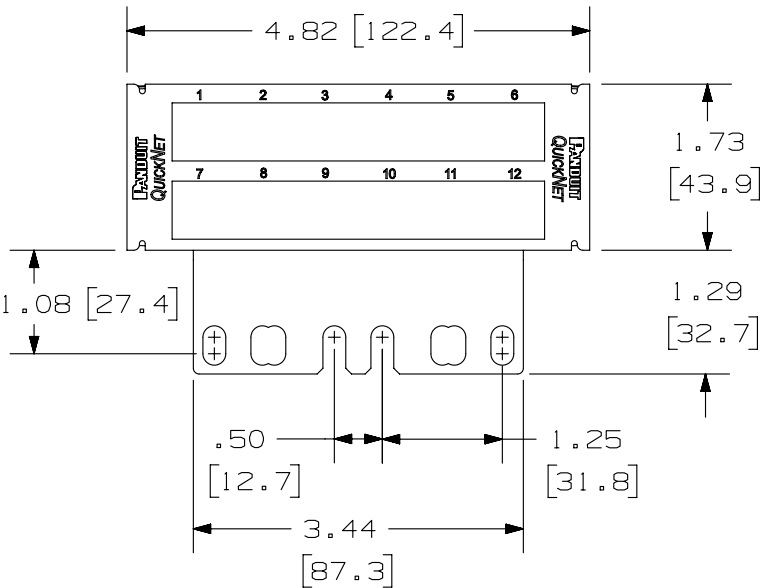

PANDUIT PART NUMBER	DESCRIPTION
FQCBRUA	QUICKNET ZERO RU BRACKET

NOTES:

- SEE CURRENT CATALOG OR PANDUIT WEBSITE FOR PART NUMBER SUFFIXES TO INDICATE COLOR AND/OR PACKAGE QUANTITIES.
- SEE CATALOG FOR COMPLETE LIST OF PARTS APPLICABLE FOR USE WITH THIS PRODUCT.
- FOR USE WITH PANDUIT STANDARD RACKS WITHOUT VERTICAL CABLE MANAGERS.
- MATERIALS:  
A. BRACKET: POWDER COATED STEEL  
B. SLIDE GUIDE: PLASTIC
- ALL MATERIALS AND COMPONENTS USED MEET THE MATERIAL RESTRICTIONS OF RoHS, (EUROPEAN DIRECTIVE 2002/95/EC ON THE RESTRICTION OF HAZARD SUBSTANCES) AS PROPOSED BY THE RoHS TECHNICAL ADAPTATION COMMITTEE.
- DIMENSIONS IN BRACKETS ARE METRIC [ mm ].

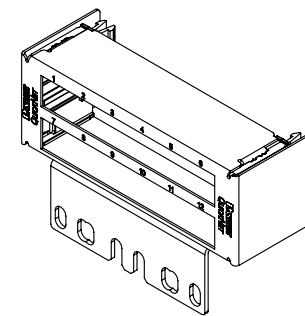

PART NUMBER		FQCBRUA	
TITLE			
QUICKNET ZERO RU BRACKET			
CUSTOMER DRAWING			
ITEM REVISION NAME		F00015AD/02	
DATASET FILE NAME		F00015AD_DC/02A	
UNLESS OTHERWISE SPECIFIED, DIMENSIONAL TOLERANCES ARE: IN [ mm ]		MATERIAL:	
.x ± .xxx ± .010 [ .3 ]		DRAWING NUMBER:	
.xx ± .03 [ .8 ]		F00015AD-DC	
ANGLES ±		THIRD ANGLE PROJECTION	
DRAWN BY	DATE	CHK	SCALE
MC	09-19-08	TMS	NONE
SHT 1 OF 1			SIZE
			A

REV	DATE	BY	CHK	APR	DESCRIPTION	ECN
2	2/16/15	JSP	WJM	TMK	A. UPDATE DRAWING TITLE BLOCK.	F00015AD-DC

D10100DA/14