

THIS COPY IS PROVIDED ON A RESTRICTED BASIS AND IS NOT TO BE USED IN ANY WAY DETRIMENTAL TO THE INTERESTS OF PANDUIT CORP.

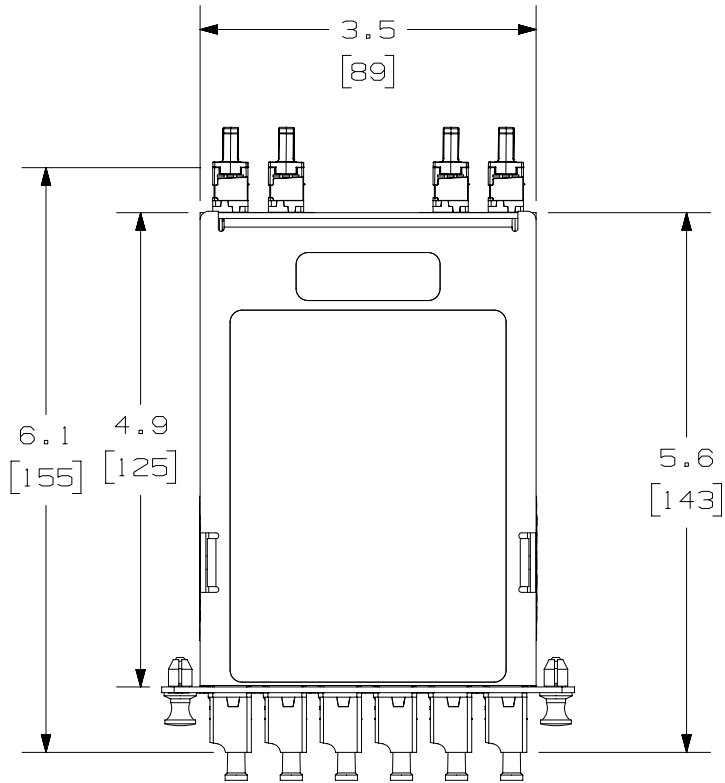

NOTES:

1. SEE CURRENT CATALOG FOR COMPLETE LIST OF PARTS APPLICABLE FOR USE WITH THIS PRODUCT.
2. MATERIALS:
 - A. ENCLOSURE: ALUMINUM
 - B. ADAPTERS: COMPOSITE PLASTIC
3. PART WEIGHT: 7 OZ [200 G]
4. DIMENSIONS IN BRACKETS ARE METRIC [mm]
5. ALL DIMENSIONS ARE FOR REFERENCE ONLY
6. ALL MATERIALS USED MEET THE MATERIAL RESTRICTIONS OF RoHS, (EUROPEAN DIRECTIVE 2011/65/EC ON THE RESTRICTION OF HAZARDOUS SUBSTANCES) AS PROPOSED BY THE RoHS TECHNICAL ADAPTATION COMMITTEE.
7. SEE SHEET 2 FOR PORT MAPPING
8. PART NUMBERS:
 - A. FCT-7ZD - 70/30 FIBER OPTIC 24 CHANNEL OM4 TAP CASSETTE LC TO MPO
 - B. FCT-79UD - 70/30 FIBER OPTIC 24 CHANNEL OS2 TAP CASSETTE LC TO MPO
9. TOLERANCE: +/-0.03" [0.8]

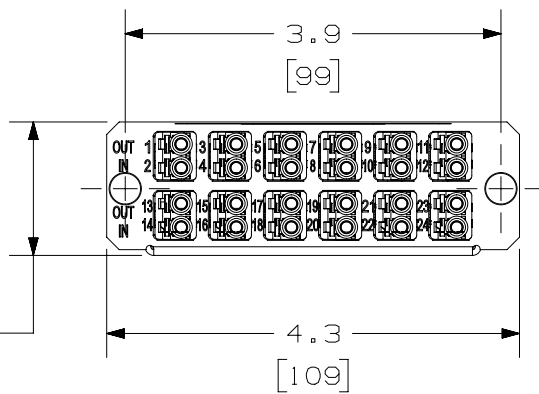
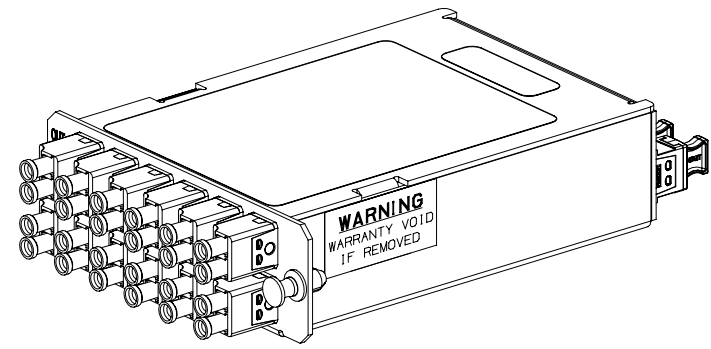

PART NUMBER		FCT-7ZD, FCT-79UD		
TITLE		QuickNet Opticom Fiber Tap Cassette, 24 Channel, LC to MPO		
ITEM REVISION NAME		CUSTOMER DRAWING		
DATASET FILE NAME		13F218CQ/00		
MATERIAL		13F218CQ_DC/00A		
DRAWN BY		THIRD ANGLE PROJECTION		
DATE		DRAWING NUMBER		
06/16/22		13F218CQ-DC		
CHK		SCALE		
JGD		NONE		
SHEET 1 OF 2		SIZE		
A		A		

00A	12-15-22	SAT/ACAM	JGD	EJH	RELEASED TO PRODUCTION	13F218CQ-DC
REV	DATE	BY	CHK	APR	DESCRIPTION	ECN

THIS COPY IS PROVIDED ON A RESTRICTED BASIS AND IS NOT TO BE USED IN ANY WAY DETRIMENTAL TO THE INTERESTS OF PANDUIT CORP.

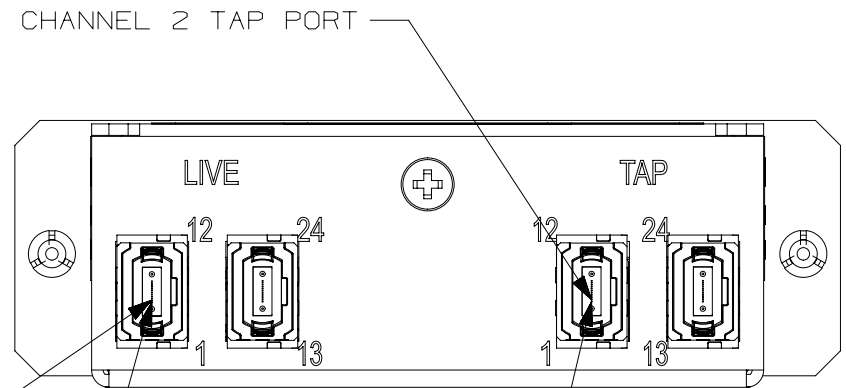
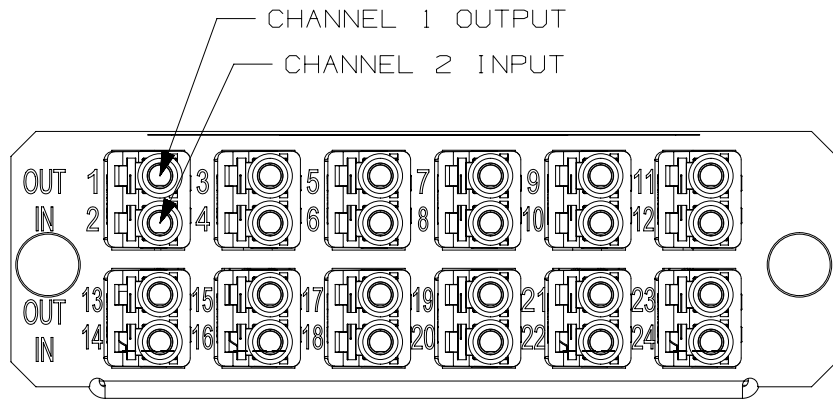

CHANNEL	INPUT PORT	OUTPUT PORT (70%)	TAP PORT (30%)
1	1 LIVE (MPO)	1 OUT (LC)	1 TAP (MPO)
2	2 IN (LC)	2 LIVE (MPO)	2 TAP (MPO)
3	3 LIVE (MPO)	3 OUT (LC)	3 TAP (MPO)
4	4 IN (LC)	4 LIVE (MPO)	4 TAP (MPO)
5	5 LIVE (MPO)	5 OUT (LC)	5 TAP (MPO)
6	6 IN (LC)	6 LIVE (MPO)	6 TAP (MPO)
7	7 LIVE (MPO)	7 OUT (LC)	7 TAP (MPO)
8	8 IN (LC)	8 LIVE (MPO)	8 TAP (MPO)
9	9 LIVE (MPO)	9 OUT (LC)	9 TAP (MPO)
10	10 IN (LC)	10 LIVE (MPO)	10 TAP (MPO)
11	11 LIVE (MPO)	11 OUT (LC)	11 TAP (MPO)
12	12 IN (LC)	12 LIVE (MPO)	12 TAP (MPO)

CHANNEL	INPUT PORT	OUTPUT PORT (70%)	TAP PORT (30%)
13	13 LIVE (MPO)	13 OUT (LC)	13 TAP (MPO)
14	14 IN (LC)	14 LIVE (MPO)	14 TAP (MPO)
15	15 LIVE (MPO)	15 OUT (LC)	15 TAP (MPO)
16	16 IN (LC)	16 LIVE (MPO)	16 TAP (MPO)
17	17 LIVE (MPO)	17 OUT (LC)	17 TAP (MPO)
18	18 IN (LC)	18 LIVE (MPO)	18 TAP (MPO)
19	19 LIVE (MPO)	19 OUT (LC)	19 TAP (MPO)
20	20 IN (LC)	20 LIVE (MPO)	20 TAP (MPO)
21	21 LIVE (MPO)	21 OUT (LC)	21 TAP (MPO)
22	22 IN (LC)	22 LIVE (MPO)	22 TAP (MPO)
23	23 LIVE (MPO)	23 OUT (LC)	23 TAP (MPO)
24	24 IN (LC)	24 LIVE (MPO)	24 TAP (MPO)

PART NUMBER
FCT-7ZD, FCT-79UD

TITLE
QuickNet Opticom Fiber Tap Cassette, 24 Channel, LC to MPO

CUSTOMER DRAWING

ITEM REVISION NAME
13F218CQ/00

DATASET FILE NAME
13F218CQ_DC/00A

MATERIAL
N/A

DRAWING NUMBER
13F218CQ-DC

THIRD ANGLE PROJECTION

REV DATE BY CHK APR DESCRIPTION ECN

SEE PAGE 1 FOR REVISION HISTORY

DRAWN BY: **ACAM** DATE: **06/16/22** CHK: **JGD** SCALE: **NONE**

SHEET 2 OF 2 SIZE: **A**

A-SIZE CUSTOMER

2

1

2

1