

Gauge Identification (clear)

MP528 Specifications

- Cable jacket diameter 0.140 - 0.160 in.
- 28 AWG stranded or solid conductor maximum insulated diameter 0.024 in.
- Panduit recommends T568B wiring scheme for use with cable constructed with the brown pair opposing the orange pair.

Wiring Sequence

Pin #	8	7	6	5	4	3	2	1
T568B	BRN	BRN/WHT	GRN	BLU/WHT	BLU	GRN/WHT	ORG	ORG/WHT
T568A	BRN	BRN/WHT	ORG	BLU/WHT	BLU	ORG/WHT	GRN	GRN/WHT

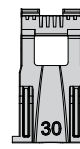

Gauge Identification (tinted)

MP530 Specifications

- Cable jacket diameter 0.122 - 0.130 in.
- 30 AWG stranded maximum insulated diameter 0.021 in.
- Panduit recommends T568B wiring scheme for use with cable constructed with the brown pair opposing the orange pair.

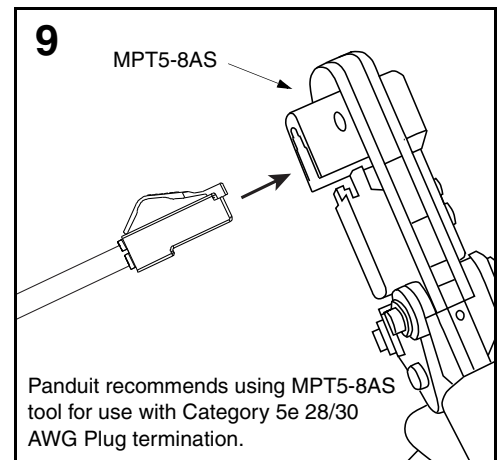
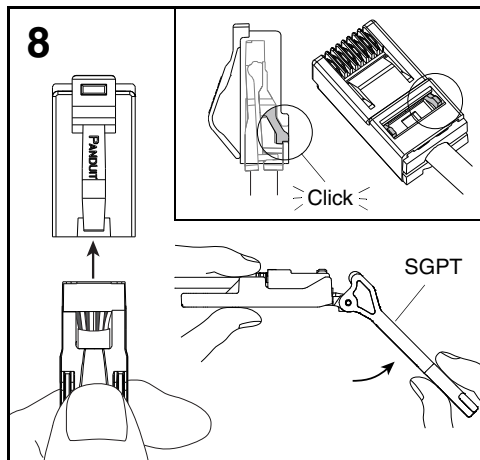
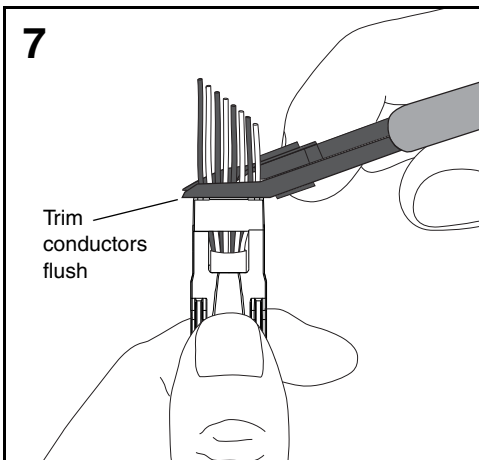
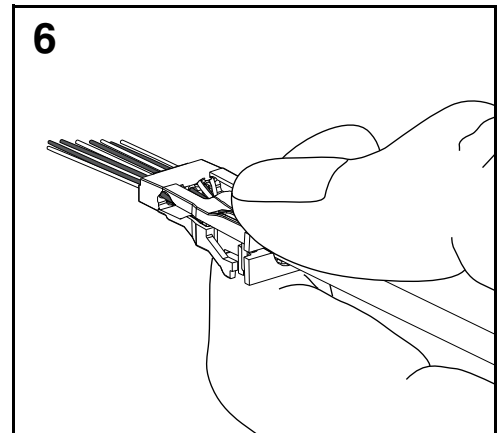
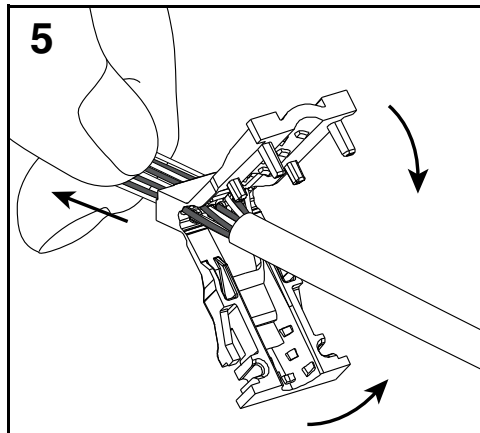
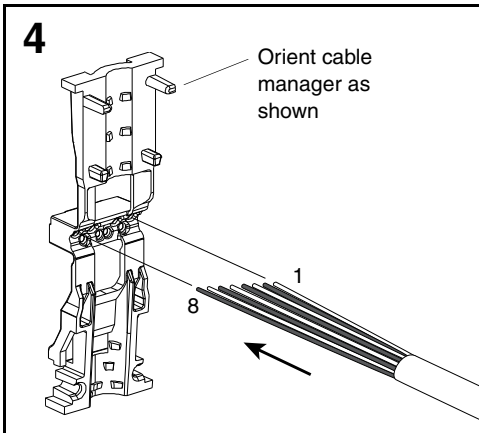
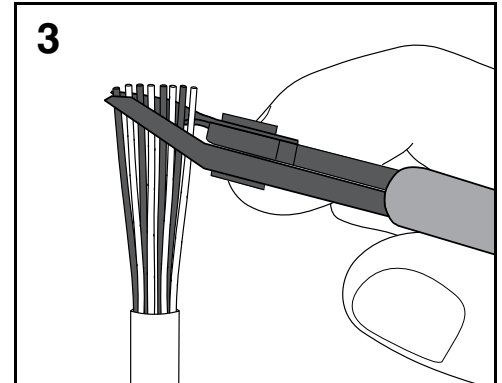
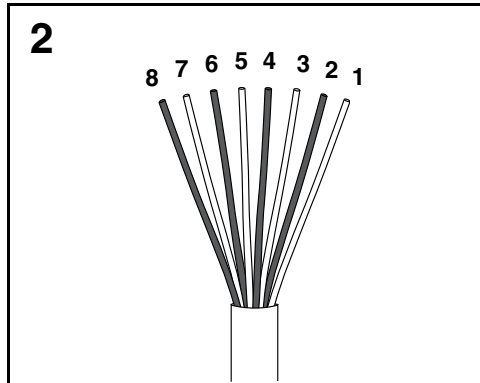
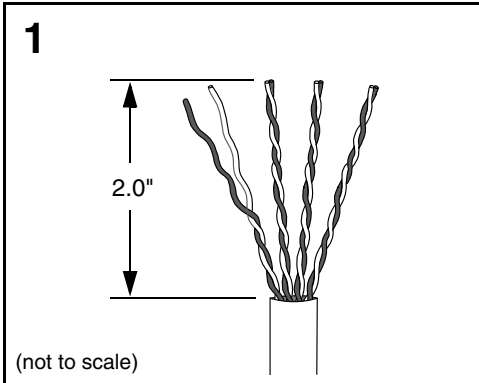

For Instructions in Local Languages and Technical Support:

www.panduit.com/resources/install_maintain.asp



www.panduit.com

E-mail: techsupport@panduit.com

Phone: 866-405-6654