

THIS COPY IS PROVIDED ON A RESTRICTED BASIS AND IS NOT TO BE USED IN ANY WAY DETRIMENTAL TO THE INTERESTS OF PANDUIT CORP.

- VISIT OUR ON-LINE CATALOG AT WWW.PANDUIT.COM FOR A LIST OF CURRENT PARTS APPLICABLE FOR USE WITH THIS PRODUCT.
- PRIMARY DIMENSIONS ARE IN MILLIMETERS.
- EQUIPMENT RAILS (E-RAILS) ARE SET TO 738mm [29.1"] FROM THE FACTORY. E-RAILS ARE INFINITELY ADJUSTABLE, FROM A MINIMUM OF 128mm APART, TO A MAXIMUM FOUND IN THE CHART ON SHEET 2.
- CAN BE USED WITH ANY 19" EIA STANDARD COMPONENT IN ADDITION TO ALL PANDUIT HORIZONTAL CABLE MANAGEMENT AND PATCH PANEL PRODUCTS.
- EIA UNIVERSAL STANDARD HOLE PROGRESSION ON EQUIPMENT RAILS
- PARTS SUPPLIED:
  - BASE CABINET
  - FRONT CURVED PERFORATED SINGLE HINGE DOOR, 69% OPEN AREA, OPENS UP TO 165° WHEN GANGED
  - REAR PERFORATED SPLIT DOOR, 69% OPEN AREA, OPENS UP TO 150° WHEN GANGED
  - EQUIPMENT RAILS FRONT & REAR (E-RAILS) (SEE CHART ON SHEET 2)
  - (2) PAIRS SPLIT SIDE PANELS
  - PDU MOUNTING / CABLE MANAGEMENT BRACKETS (CMB)
  - SWIVEL CASTERS
  - HARDWARE KIT CONTAINING:
    - (40) M6 CAGE NUTS
    - (40) M6 PHILIPS HEAD SCREWS
    - (4) GANGING BRACKETS
    - (8) M5 TORX (T25) THREAD CUTTING SCREWS
    - (4) RINGS OF CABINET LOCK KEYS WITH (2) KEYS PER RING.
  - LEVELING LEGS
  - INSTRUCTION SHEET
- RACK UNIT SPACING NUMERALS ARE PRINTED ON EQUIPMENT MOUNTING RAILS, NUMBERS UP TO 8.
- FULLY BONDED STRUCTURE WHEN ASSEMBLED PER INSTRUCTIONS.
- STATIC LOAD RATING 1500 Kg (3300 LBS)
- ROLLING LOAD RATING 500 Kg (1102 LBS)

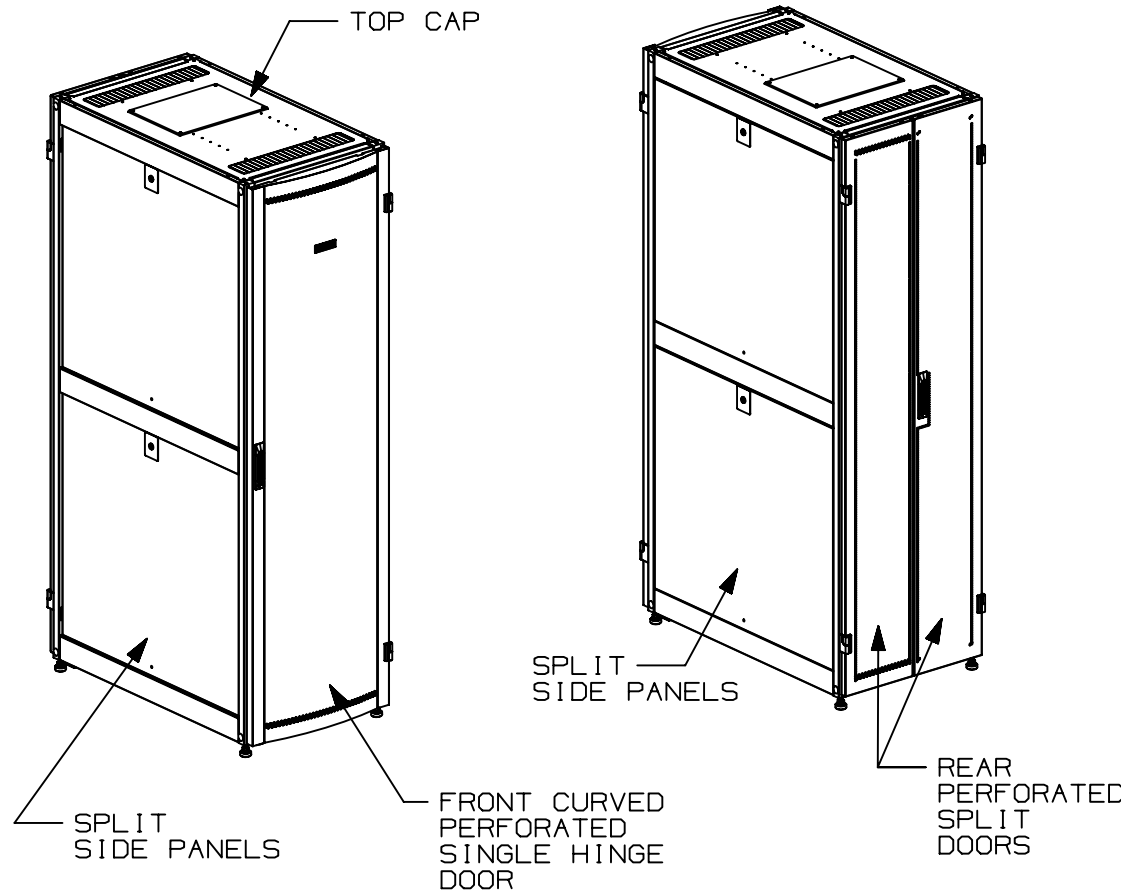

REV	DATE	BY	CHK	APR	DESCRIPTION	ECN
02A	7/13/20	MEX-JAGC	PATR	ELE	PART NOS. WITHOUT SIDE PANELS REMOVED	V09002DP/03
00A	12-4-19	MES	PATR	SJP	RELEASED TO PRODUCTION	V09002DP

TITLE		NET-VERSE D-TYPE ENHANCED CABINET 600 WIDE X 42/45/48 RU X 1000mm/1200mm DEEP (DNE6**2*) CUSTOMER DRAWING		
ITEM REVISION NAME		00568EAA/02		
DATASET FILE NAME		00568EAA_DC/02A		
MATERIAL:		N/A		
DRAWING NUMBER:		00568EAA-DC		
DRAWN BY	DATE	CHK	SCALE	
MES	12-4-19	PATR	NONE	
THIRD ANGLE PROJECTION		SHT 1 OF 7		
SIZE		A		

D10100DA/16

THIS COPY IS PROVIDED ON A RESTRICTED BASIS AND IS NOT TO BE USED IN ANY WAY DETRIMENTAL TO THE INTERESTS OF PANDUIT CORP.

PART NO.	DESCRIPTION	FRAME HEIGHT	FRAME DEPTH	E-RAIL MAXIMUM SPACING	CABINET UNPACKAGED WEIGHT	CABINET SHIPPING WEIGHT
DNE6212*	NET-VERSE D-TYPE CABINET 600mm WIDE X 42RU X 1000mm DEEP	1998.0 (78.66)	1000.0 (39.37)	738 (29.1) WITH CMB 871 (34.3) WITHOUT CMB	121 Kg/EACH 266 LBS/EACH	150 Kg/EACH 331 LBS/EACH
DNE6222*	NET-VERSE D-TYPE CABINET 600mm WIDE X 42RU X 1200mm DEEP	1998.0 (78.66)	1200.0 (47.24)	938 (36.9) WITH CMB 1071 (42.2) WITHOUT CMB	131 Kg/EACH 289 LBS/EACH	164 Kg/EACH 362 LBS/EACH
DNE6512*	NET-VERSE D-TYPE CABINET 600mm WIDE X 45RU X 1000mm DEEP	2131.4 (83.91)	1000.0 (39.37)	738 (29.1) WITH CMB 871 (34.3) WITHOUT CMB	125 Kg/EACH 275 LBS/EACH	156 Kg/EACH 344 LBS/EACH
DNE6522*	NET-VERSE D-TYPE CABINET 600mm WIDE X 45RU X 1200mm DEEP	2131.4 (83.91)	1200.0 (47.24)	938 (36.9) WITH CMB 1071 (42.2) WITHOUT CMB	135 Kg/EACH 297 LBS/EACH	175 Kg/EACH 386 LBS/EACH
DNE6812*	NET-VERSE D-TYPE CABINET 600mm WIDE X 48RU X 1000mm DEEP	2264.7 (89.16)	1000.0 (39.37)	738 (29.1) WITH CMB 871 (34.3) WITHOUT CMB	129 Kg/EACH 284 LBS/EACH	160 Kg/EACH 353 LBS/EACH
DNE6822*	NET-VERSE D-TYPE CABINET 600mm WIDE X 48RU X 1200mm DEEP	2264.7 (89.16)	1200.0 (47.24)	938 (36.9) WITH CMB 1071 (42.2) WITHOUT CMB	139 Kg/EACH 306 LBS/EACH	175 Kg/EACH 386 LBS/EACH

NOTE: "\*" DENOTES COLOR - ADD SUFFIX "B" FOR BLACK AND "W" FOR WHITE

B

B

A

A

D10100DA/16

						TITLE <b>NET-VERSE D-TYPE ENHANCED CABINET                  600 WIDE X 42/45/48 RU X 1000mm/1200mm DEEP                  (DNE6**2*)                  CUSTOMER DRAWING</b>	
						ITEM REVISION NAME <b>00568EAA/02</b>	
						DATASET FILE NAME <b>00568EAA_DC/02A</b>	
						MATERIAL: N/A	
02A	7/13/20	MEX-JAGC	PATR	ELE	SEE SHEET ONE FOR REVISIONS	V09002DP/03	
00A	12-4-19	MES	PATR	SJP	SEE SHEET ONE FOR REVISIONS	V09002DP	
REV	DATE	BY	CHK	APR	DESCRIPTION	ECN	

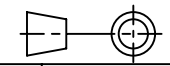

THIRD ANGLE PROJECTION



DRAWING NUMBER:  
00568EAA-DC

DRAWN BY	DATE	CHK	SCALE	SHT 2 OF 7	SIZE
MES	12-4-19	PATR	NONE		A

THIS COPY IS PROVIDED ON A RESTRICTED BASIS AND IS NOT TO BE USED IN ANY WAY DETRIMENTAL TO THE INTERESTS OF PANDUIT CORP.

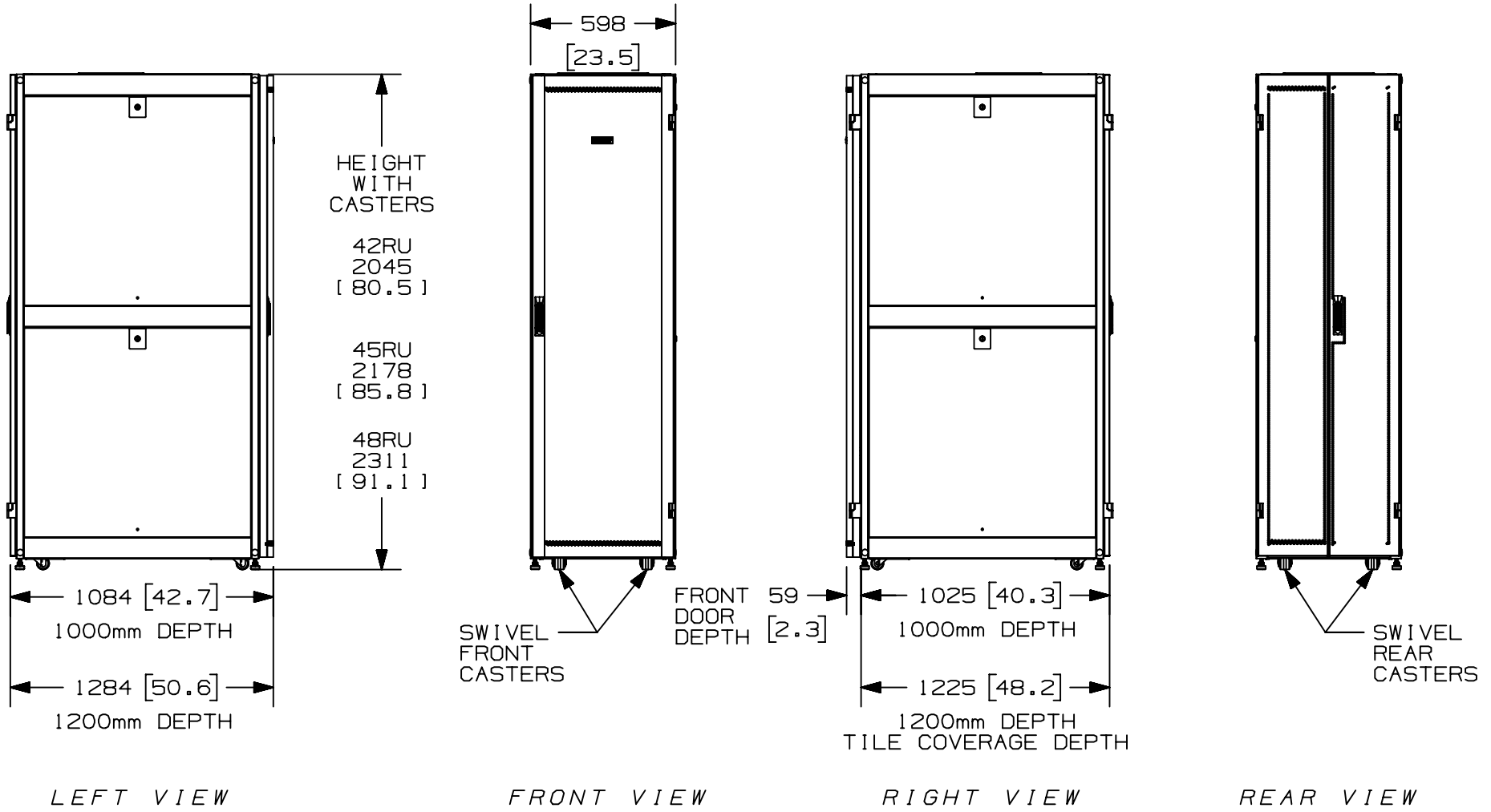

LEFT VIEW

FRONT VIEW

RIGHT VIEW

REAR VIEW

02A	7/13/20	MEX-JAGC	PATR	ELE	SEE SHEET ONE FOR REVISIONS	V09002DP/03
00A	12-4-19	MES	PATR	SJP	SEE SHEET ONE FOR REVISIONS	V09002DP
REV	DATE	BY	CHK	APR	DESCRIPTION	ECN

<p>TITLE</p> <p><b>NET-VERSE D-TYPE ENHANCED CABINET</b>  <b>600 WIDE X 42/45/48 RU X 1000mm/1200mm DEEP</b>  <b>(DNE6**2*)</b>          CUSTOMER DRAWING</p>					
<p>ITEM REVISION NAME</p> <p><b>00568EAA/02</b></p>					
<p>DATASET FILE NAME</p> <p><b>00568EAA_DC/02A</b></p>					
<p>MATERIAL:</p> <p>N/A</p>					<p>DRAWING NUMBER:</p> <p><b>00568EAA-DC</b></p>
<p>DRAWN BY</p> <p>MES</p>		<p>DATE</p> <p>12-4-19</p>		<p>CHK</p> <p>PATR</p>	
<p>SCALE</p> <p>NONE</p>		<p>THIRD ANGLE PROJECTION</p>		<p>SHT 3 OF 7</p>	
<p>SIZE</p> <p>A</p>					

D10100DA/16

THIS COPY IS PROVIDED ON A RESTRICTED BASIS AND IS NOT TO BE USED IN ANY WAY DETRIMENTAL TO THE INTERESTS OF PANDUIT CORP.

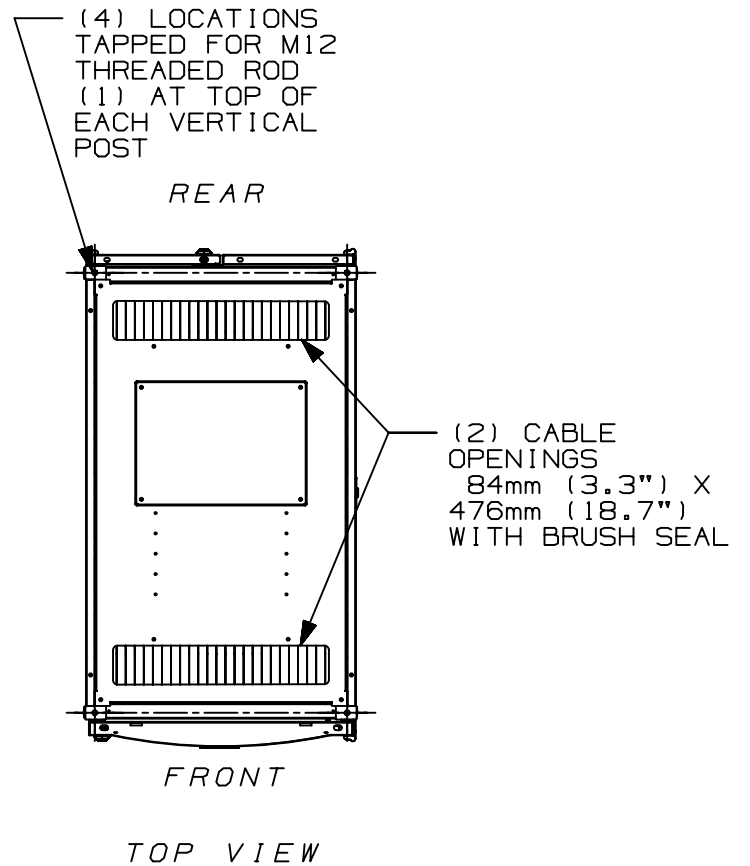
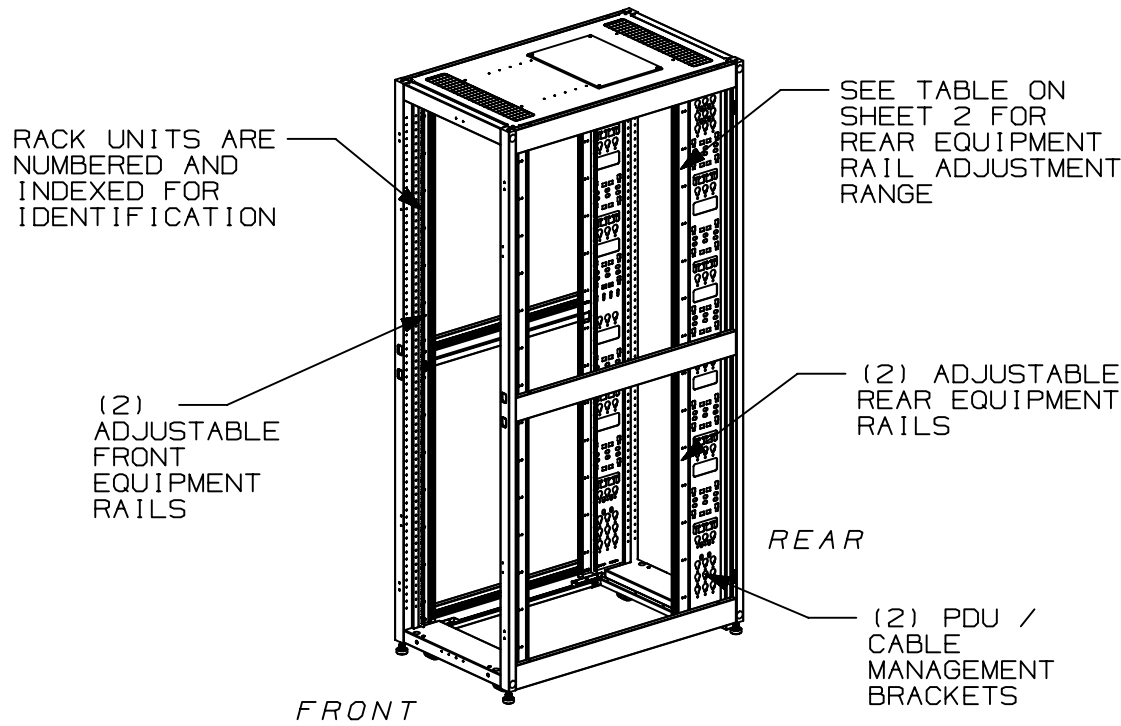

FRONT DOOR, REAR DOOR, AND SIDE PANELS NOT SHOWN

D10100DA/16

02A	7/13/20	MEX-JAGC	PATR	ELE	SEE SHEET ONE FOR REVISIONS	V09002DP/03
00A	12-4-19	MES	PATR	SJP	SEE SHEET ONE FOR REVISIONS	V09002DP
REV	DATE	BY	CHK	APR	DESCRIPTION	ECN

TITLE <b>NET-VERSE D-TYPE ENHANCED CABINET</b> <b>600 WIDE X 42/45/48 RU X 1000mm/1200mm DEEP</b> <b>(DNE6**2*)</b> CUSTOMER DRAWING					
ITEM REVISION NAME <b>00568EAA/02</b>					
DATASET FILE NAME <b>00568EAA_DC/02A</b>					
MATERIAL: N/A					DRAWING NUMBER: <b>00568EAA-DC</b>
DRAWN BY <b>MES</b>		DATE <b>12-4-19</b>		CHK <b>PATR</b>	
SCALE <b>NONE</b>		THIRD ANGLE PROJECTION 			
SHT 4 OF 7			SIZE <b>A</b>		

THIS COPY IS PROVIDED ON A RESTRICTED BASIS AND IS NOT TO BE USED IN ANY WAY DETRIMENTAL TO THE INTERESTS OF PANDUIT CORP.

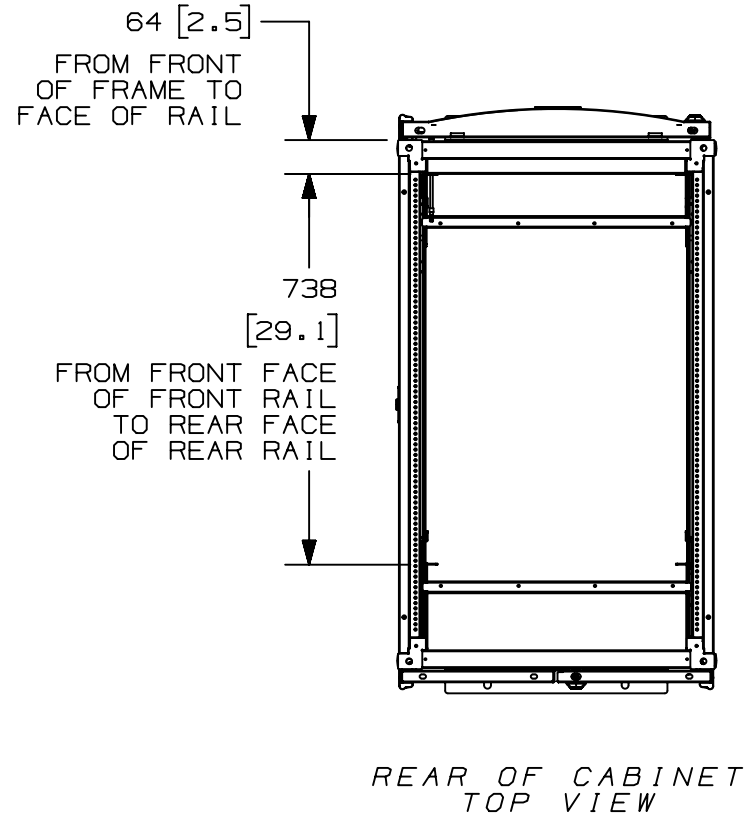
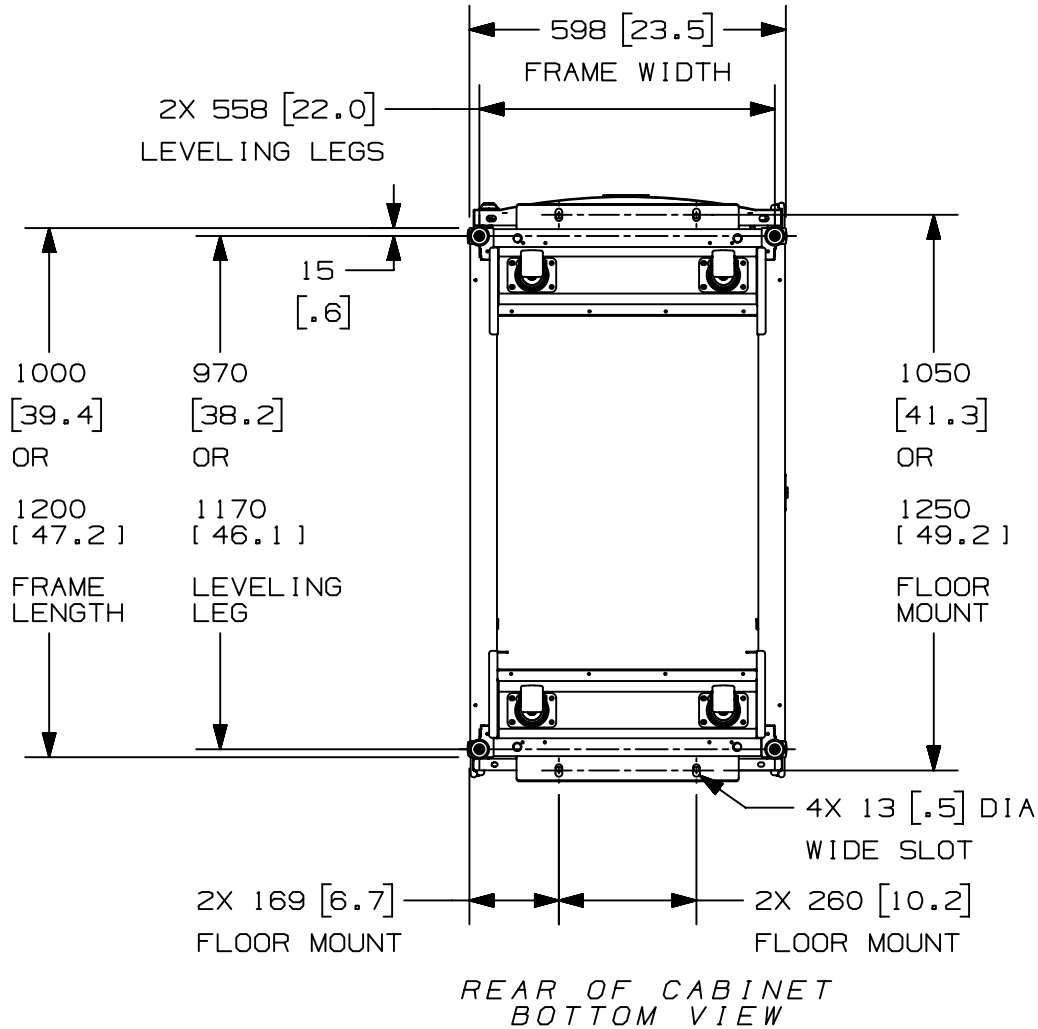

SOME PARTS REMOVED FOR CLARITY

02A	7/13/20	MEX-JAGC	PATR	ELE	SEE SHEET ONE FOR REVISIONS	V09002DP/03
00A	12-4-19	MES	PATR	SJP	SEE SHEET ONE FOR REVISIONS	V09002DP
REV	DATE	BY	CHK	APR	DESCRIPTION	ECN

TITLE		NET-VERSE D-TYPE ENHANCED CABINET 600 WIDE X 42/45/48 RU X 1000mm/1200mm DEEP (DNE6**2*) CUSTOMER DRAWING	
ITEM REVISION NAME		00568EAA/02	
DATASET FILE NAME		00568EAA_DC/02A	
MATERIAL		N/A	
DRAWING NUMBER		00568EAA-DC	
DRAWN BY		DATE	CHK
MES	12-4-19	PATR	SCALE
THIRD ANGLE PROJECTION		NONE	
SHT 5 OF 7		A	

D10100DA/16

THIS COPY IS PROVIDED ON A RESTRICTED BASIS AND IS NOT TO BE USED IN ANY WAY DETRIMENTAL TO THE INTERESTS OF PANDUIT CORP.

TOP CAP OPENING CABLE CAPACITY								
	AREA		CABLE CAPACITY* (CABLE DIA)					
	CM <sup>2</sup>	IN <sup>2</sup>	CAT 6A (8.99mm)	CAT 6A (7.87mm)	CAT 6A (7.54mm)	CAT 6 (6.35mm)	CAT 5e (4.75mm)	FIBER (3mm)
84mm x 476mm FRONT AND REAR OPENINGS (EACH)	339.6	61.9	251	328	358	504	902	2261

\* CAPACITY CALCULATION ASSUMES 40% FILL FACTOR

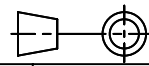

										<b>TITLE</b> NET-VERSE D-TYPE ENHANCED CABINET 600 WIDE X 42/45/48 RU X 1000mm/1200mm DEEP (DNE6**2*) CUSTOMER DRAWING			
										<b>ITEM REVISION NAME</b> 00568EAA/02			
										<b>DATASET FILE NAME</b> 00568EAA_DC/02A			
												<b>MATERIAL:</b> N/A	
02A	7/13/20	MEX-JAGC	PATR	ELE	SEE SHEET ONE FOR REVISIONS								
00A	12-4-19	MES	PATR	SJP	SEE SHEET ONE FOR REVISIONS								
												<b>DRAWING NUMBER:</b> 00568EAA-DC	
												 THIRD ANGLE PROJECTION	
REV	DATE	BY	CHK	APR	DESCRIPTION		ECN	DRAWN BY	DATE	CHK	SCALE		SIZE
								MES	12-4-19	PATR	NONE	SHT 6 OF 7	A

THIS COPY IS PROVIDED ON A RESTRICTED BASIS AND IS NOT TO BE USED IN ANY WAY DETRIMENTAL TO THE INTERESTS OF PANDUIT CORP.

FROM CENTER OF TOP MOUNTING BUTTON TO TOP CAP:

42RU 137.5 [ 5.4 ]  
 45RU 204.1 [ 8.0 ]  
 48RU 114.2 [ 4.5 ]

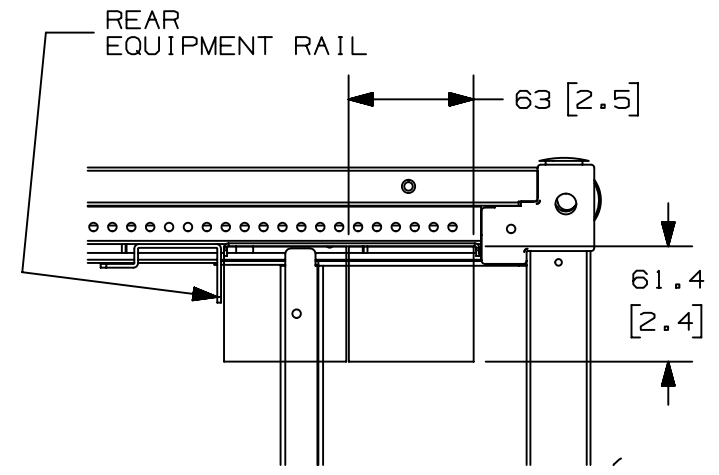
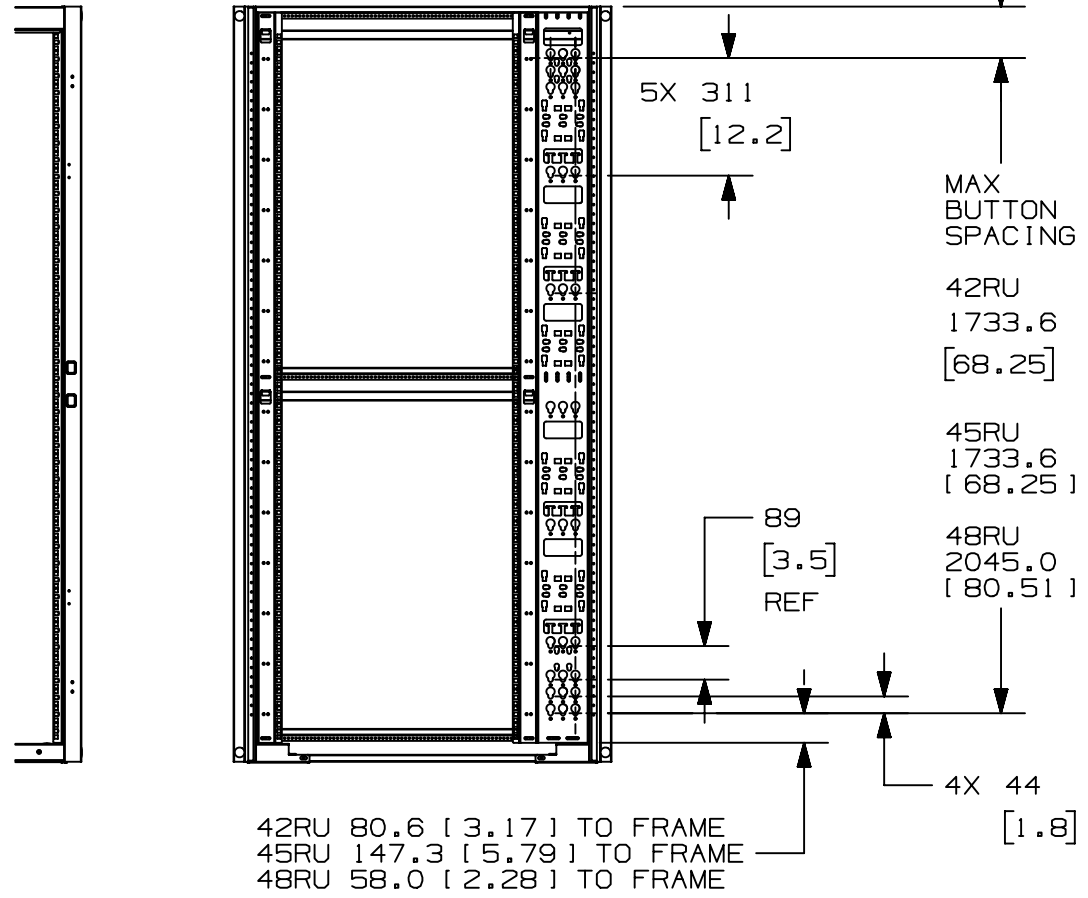

TOP VIEW

PDU FIT:  
 MAXIMUM WIDTH OF 63mm FOR (2) PDU'S MOUNTED ON ONE BRACKET,  
 OR (1) 130mm WIDE PDU.

PDU'S WILL ENTER EIA AREA BEHIND REAR EQUIPMENT RAILS.

SOME COMPONENTS REMOVED FOR CLARITY

REAR VIEW

RIGHT VIEW

TITLE		NET-VERSE D-TYPE ENHANCED CABINET 600 WIDE X 42/45/48 RU X 1000mm/1200mm DEEP (DNE6**2*) CUSTOMER DRAWING		
ITEM REVISION NAME		00568EAA/02		
DATASET FILE NAME		00568EAA_DC/02A		
MATERIAL:		N/A		
DRAWING NUMBER:		00568EAA-DC		
DRAWN BY		DATE	CHK	SCALE
MES		12-4-19	PATR	NONE
THIRD ANGLE PROJECTION				
REV	DATE	BY	CHK	APR
02A	7/13/20	MEX-JAGC	PATR	ELE
00A	12-4-19	MES	PATR	SJP
DESCRIPTION		ECN		
SEE SHEET ONE FOR REVISIONS		V09002DP/03		
SEE SHEET ONE FOR REVISIONS		V09002DP		
DESCRIPTION		ECN		

D10100DA/16