

THIS COPY IS PROVIDED ON A RESTRICTED BASIS AND IS NOT TO BE USED IN ANY WAY DETRIMENTAL TO THE INTERESTS OF PANDUIT CORP.

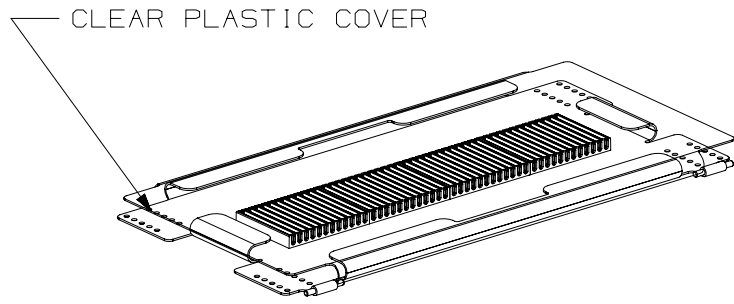

NOTES:

- VISIT OUR ON-LINE CATALOG AT WWW.PANDUIT.COM FOR A LIST OF CURRENT PARTS APPLICABLE FOR USE WITH THIS PRODUCT.
- DIMENSIONS IN [] ARE METRIC.
- TRAY WILL HOLD UP TO 48 FUSION SPLICES.
- INCLUDED WITH SPLICE TRAY;
 - 1 CLEAR PLASTIC COVER.
 - 50 SPLICE PROTECTORS (SINGLE FIBER).
 - 10 CABLE TIES.
 - 6" HEAT SHRINK TUBING.
- ALL MATERIALS AND COMPONENTS USED MEET THE MATERIAL RESTRICTIONS OF RoHS (EUROPEAN DIRECTIVE 2011/65/EU ON THE RESTRICTION OF HAZARDOUS SUBSTANCES) AS PROPOSED BY THE RoHS TECHNICAL ADAPTATION COMMITTEE.

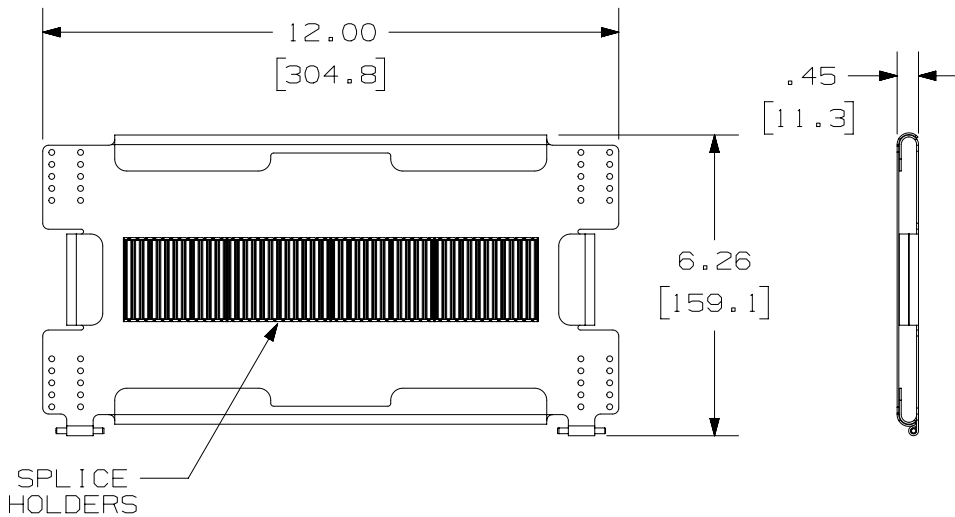

PANDUIT P/N	WEIGHT
FST48	0.52 LBS (240g)

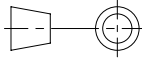
PART NUMBER		FST48		
TITLE		SPLICE TRAY UNIT 48 FUSION SPLICES CUSTOMER DRAWING		
ITEM REVISION NAME		17F088AX/05		
DATASET FILE NAME		17F088AX_DC/05A		
 THIRD ANGLE PROJECTION		PANDUIT		
MATERIAL		DRAWING NUMBER		
		17F088AX-DC		
DRAWN BY	DATE	CHK	SCALE	SIZE
SAT	09-27-18	BONS	NONE	A
REV		DATE		BY
00A		09-28-18		SAT
05A		09-28-20		SAT
DESCRIPTION		ECN		
B. WAS 4 FUSION SPLICE HOLDERS, NOTE 4.		17F088AX-DC		
A. REMOVED 2 GROMMET SLEEVES, NOTE 4.		17F088AX-DC		
INITIAL RELEASE				

A-SIZE CUSTOMER

SHEET 1 OF 1