

PATMBM4.0 BENCH MOUNT OPERATION INSTRUCTIONS FOR USE WITH: PAT1M4.0, PAT1.5M4.0, PAT1M4.0-BT & PAT1.5M4.0-BT AUTOMATIC CABLE TIE INSTALLATION TOOL SYSTEMS

Panduit Corp. 2018

Original Instructions

INTRODUCTION

The PATMBM4.0 Bench Mount allows hands-free operation, actuation and 90° pitch adjustment of the installed tool. The tool is mounted in the PATMBM4.0 so the work can be brought to the tool. Depressing the foot pedal then actuates the tool. Follow the step-by-step instructions below.



WARNING: SAFETY GLASSES MUST BE WORN AT ALL TIMES, BY ALL PERSONNEL WITHIN TEN FEET OF ANY PART OF THE SYSTEM.

Figure 1

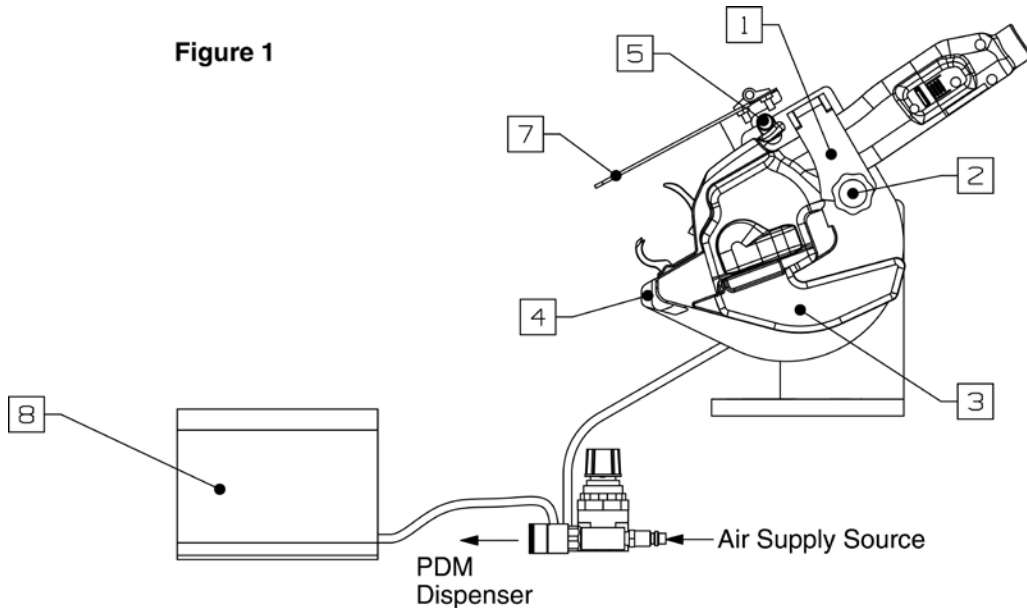
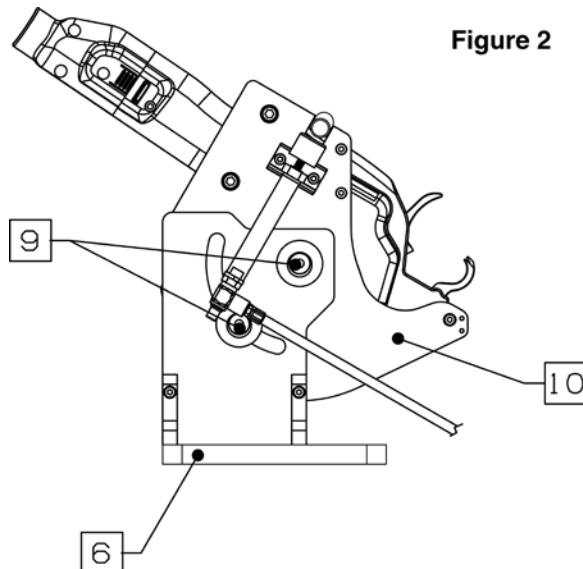

Figure 2



The following Panduit Automatic Cable Tie Installation Tool Systems: PAT1M4.0, PAT1.5M4.0, PAT1M4.0-BT or PAT1.5M4.0-BT; shall be referred to as "PAT" Systems.

SHIELD AND CYLINDER INSTALLATION



CAUTION: The shield (7) must be in position (as shown in Fig. 01 on Page 1) to protect the operator's face from cable ties.

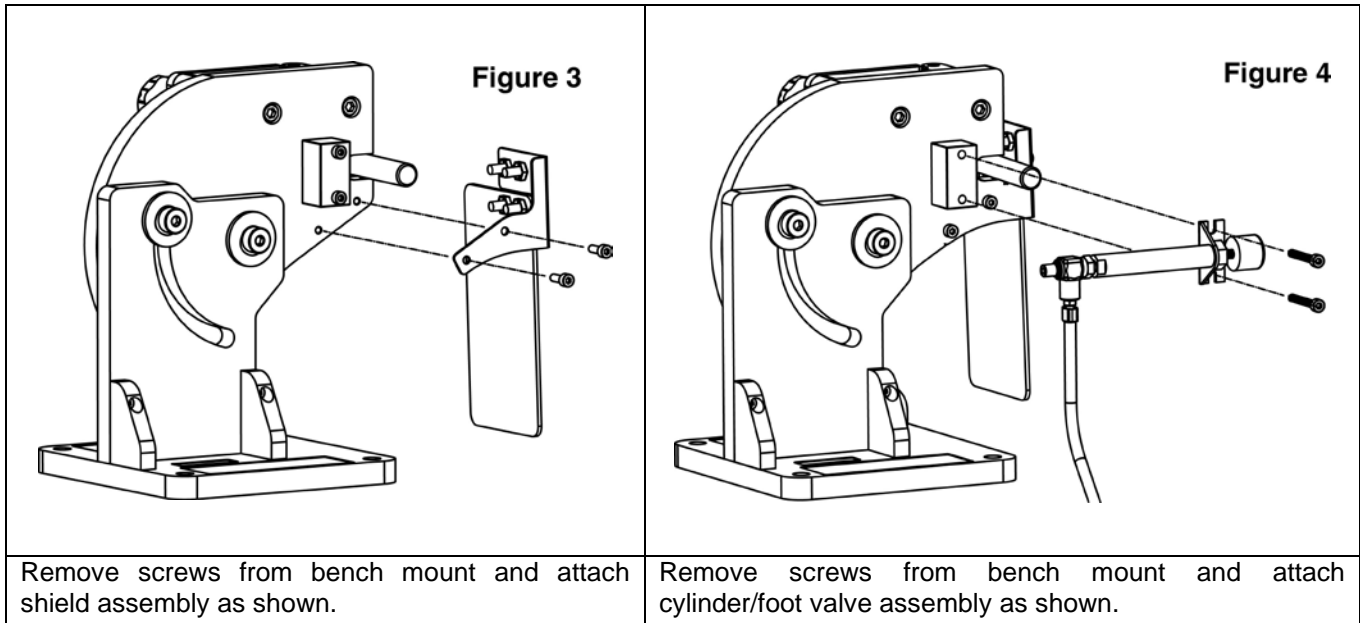

TOOL HEAD INSTALLATION

Carefully follow the installation procedure for proper operation of the PATBM4.0 Bench Mount. To adjust the pitch a 5mm hex wrench is required. There are no tools required for the installation of the tool to the bench mount.

1. If the PAT System has already been energized for operation, disconnect the female quick disconnect end of the air hose from the male air inlet on the back of the PDM Dispenser. For PAT System instructions, refer to Operation Manual (PA27647A01).
2. Loosen the Clamping Plate Knob (2) and lift the Clamping Plate (1) open.
3. Install the PAT tool in the bench mount. Position the tool with the trigger facing (as shown in Fig. 1 on Page 1). Insert the front nose of the tool against the two rubber pads in the Nose Support (4). Push the tool handle into the clamp until the tool snaps into position. Verify that the Lever (5) is above the tool trigger. Close the clamping plate and turn clamping plate knob clockwise until tight.
4. Loosen bolts (9) to adjust the angle of the Pitch Plate (10). Rotate Pitch Plate (10) till desired angle for operation is achieved. Torque bolts (9) to 20 lbf-in, to hold desired tool angle.
5. Connect the female quick disconnect of the mount airline tee to the male air inlet on the back of the PDM dispenser (refer to Fig. 1 on Page 1). Next, connect the female quick disconnect of the air hose from the air supply source to the male air inlet of the bench mount airline tee, (refer to Fig. 1 on Page 1).

NOTE: The Tip Collector (3) is not recommended for bench mounted high volume operation. If the tip collector is used, it must be emptied before it reaches its capacity of 180 cable tie cut-off tips.

NOTE: For improved performance at extreme angles, use strain relief kit (PATM-RKS); along with instruction sheet (PA26264A01).

OPERATION

The PATMBM4.0 Bench Mount is operated at the same air pressure as the PAT System, [65 PSIG (4.5 bar) with a maximum 10 PSI (0.7 bar) drop]. The small regulator that is connected to the bench mount airline is factory preset and locked. It does not need adjustment. Place the Foot Valve assembly (8) in a convenient location. Place the bundle or items to be cable tied in the open jaws of the tool and depress the foot valve until the cable tie is applied, tensioned and cut off. Move the bundle or item to the next desired cable tie location and repeat as necessary. Refer to the PAT System Operation Manual for further operation, maintenance and technical information.



CAUTION: DO NOT insert fingers in between the jaws of the tool.

MOUNTING

Securely fasten the PATMBM4.0 Bench Mount Base (6) to a bench or cart using four 5/16" or 8M screws. Use mounting template below (not to scale) for hole layout.

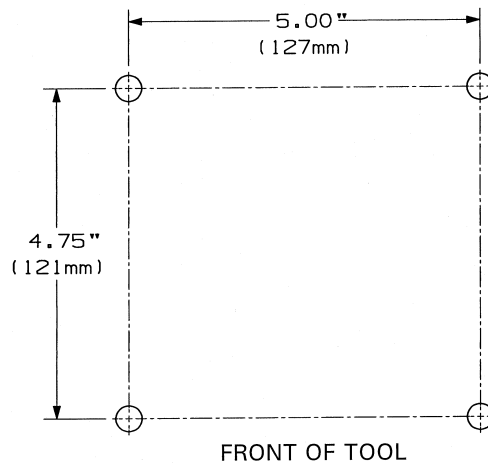
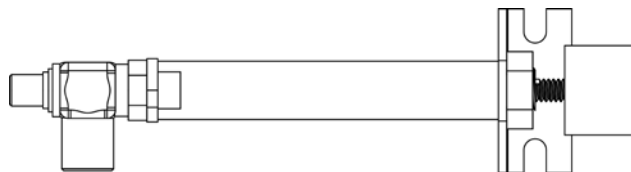

Figure 5

REPLACEMENT PART – WT28984B01 CYLINDER ASSEMBLY (Sold separately)



RECOMMENDED SYSTEM CONFIGURATION

Figure 6

NOTE: It is recommended that the entire PAT system be configured in the orientation shown.

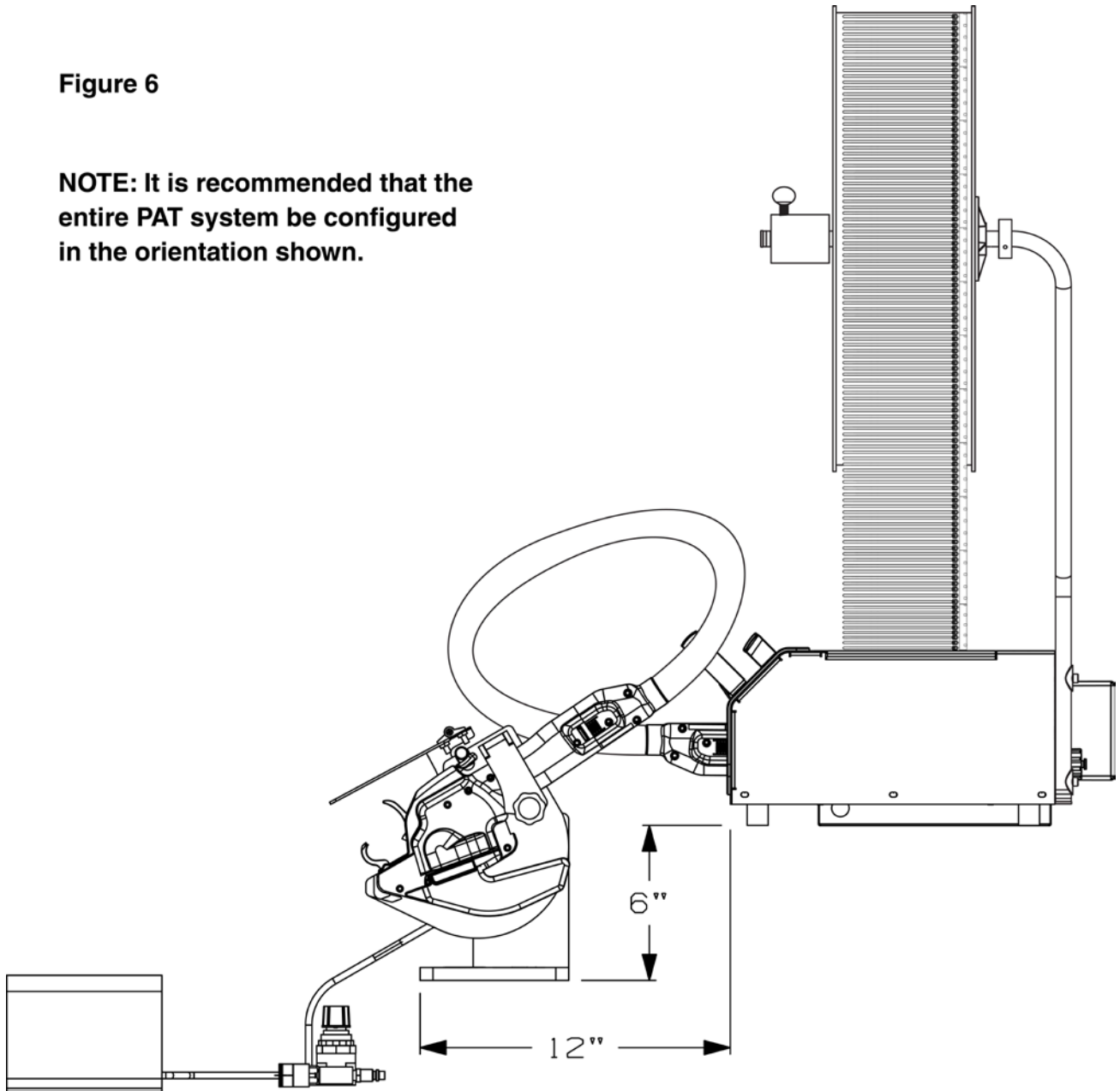

Email:
techsupport@panduit.com

EU Website:
www.panduit.com/emea

EU Email:
emeatoolservicecenter
@panduit.com



www.panduit.com

Technical Support:
Tel: 1-800-777-3300

Panduit Europe • EMEA Service Center
Almelo, Netherlands
Tel: +31 546 580 452 • Fax: +31 546 580 441