

THIS COPY IS PROVIDED ON A RESTRICTED BASIS AND IS NOT TO BE USED IN ANY WAY DETRIMENTAL TO THE INTERESTS OF PANDUIT CORP.

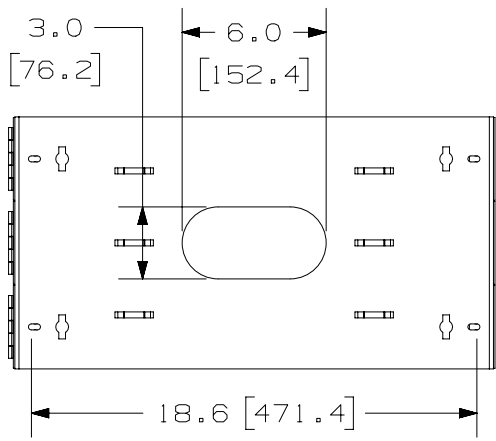

- NOTES:
1. VISIT OUR ON-LINE CATALOG AT WWW.PANDUIT.COM FOR A LIST OF CURRENT PARTS APPLICABLE FOR USE WITH THIS PRODUCT.
 2. DIMENSIONS IN [] ARE METRIC.
 3. ALL MATERIALS AND COMPONENTS USED MEET THE MATERIAL RESTRICTIONS OF RoHS (EUROPEAN DIRECTIVE 2011/65/EU ON THE RESTRICTION OF HAZARDOUS SUBSTANCES) AS PROPOSED BY THE RoHS TECHNICAL ADAPTATION COMMITTEE.
 4. WEIGHT: 17.5 lbs [7.94 kg]
 5. PART INCLUDES:
 (1) - WHB6E
 (16) - #12-24 SCREWS

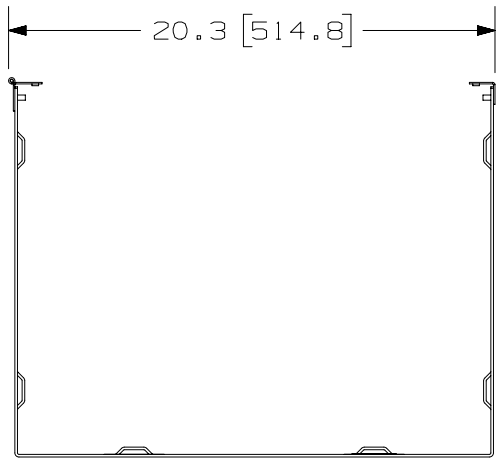
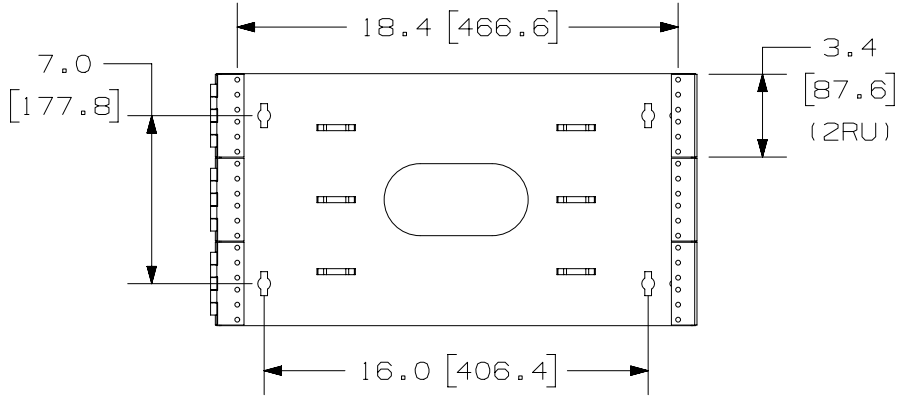
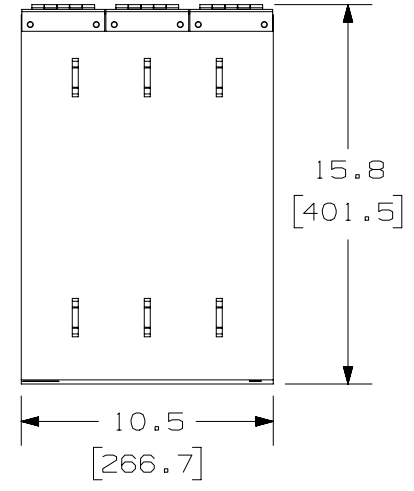

PART NUMBER		WBH6E		
TITLE				
EXTENDED HINGED WALL MOUNT BRACKET 6RU				
CUSTOMER DRAWING				
ITEM REVISION NAME		V10079AC/02		
DATASET FILE NAME		V10079AC_DC/02A		
MATERIAL		STEEL		
DRAWING NUMBER		10079-13		
DRAWN BY		DATE	CHK	SCALE
JDWE		3-13-02		NONE
SHEET 1 OF 1		A		

A-SIZE CUSTOMER

02A	4-18-23	TWV	BJN	TAM	DRAWING UPDATED	M09000SZ
REV	DATE	BY	CHK	APR	DESCRIPTION	ECN