

BENCH MOUNT FOR THE PAT1M and PAT1.5M SYSTEMS OPERATION INSTRUCTIONS

© Panduit Corp. 2016

INTRODUCTION

The PATMBM Bench Mount for the PAT1M/PAT1.5M System allows hands-free operation and actuation of the PAT1M or PAT1.5M Tool. The tool is mounted in the bench mount so the work can be brought to the tool. Depressing the foot pedal then actuates the tool. Follow the step-by-step instructions below.

INSTALLATION

Carefully follow the installation procedure for proper operation of the PATMBM Bench Mount. There are no tools required for the installation of the tool to the bench mount.

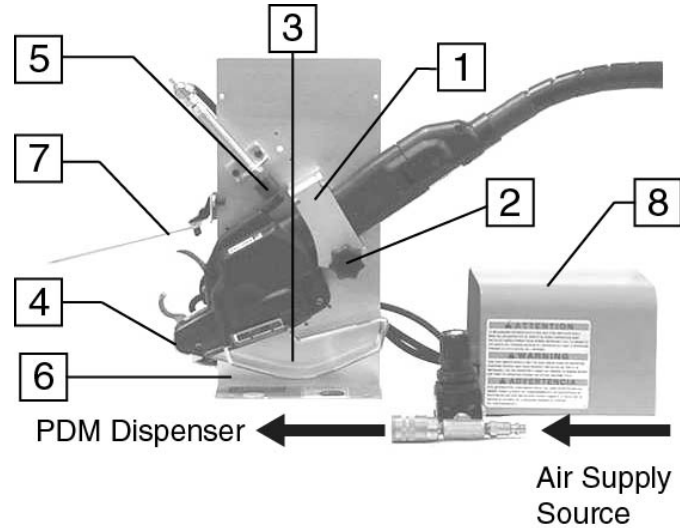

WARNING: SAFETY GLASSES MUST BE WORN AT ALL TIMES, BY ALL PERSONNEL WITHIN TEN FEET OF ANY PART OF THE SYSTEM.

1. If the PAT1M/PAT1.5M System has already been connected for operation, disconnect the female quick disconnect end of the air hose from the male air inlet on the back of the PDM Dispenser. If the PAT1M/1.5M System has not yet been installed, refer to the PAT1M/1.5M Operation Manual for specific information.
2. Loosen the Clamping Plate Knob (2) and lift the Clamping Plate (1) open.
3. Install the PAT1M or PAT1.5M Tool in the bench mount. Position the tool with the trigger facing up and insert the front nose of the tool against the two rubber pads in the Nose Support (4). Push the tool handle into the clamp until the tool snaps into position. Verify that the Rubber Core Bumper (5) is above the tool trigger. Close the clamping plate and tighten the clamping plate knob.



CAUTION: The shield (7) must be in position (as shown above) to protect the operator's face from cable ties.

NOTE: If the tool is to be used in the Alternate Assembly/Installation, adjust the shield (7) in the "down" position (as shown in figure on next page).

4. Connect the female quick disconnect of the mount airline tee to the male air inlet on the back of the PDM dispenser (refer to figure above). Next, connect the female quick disconnect of the air hose from the air supply source to the male air inlet of the bench mount airline tee (refer to figure above).

NOTE: The Tip Collector (3) is not recommended for bench mounted high volume operation. If tip collector is used, it must be emptied before it reaches its capacity of 180 cable tie cut-off tips.

OPERATION

The PATMBM Bench Mount is operated at the same air pressure as the PAT1M/PAT1.5M System [65 PSIG (4.5 bar) with a maximum 10 PSI (0.7 bar) drop]. The small regulator that is connected to the bench mount airline is factory preset and locked. It does not need adjustment. Place the Foot Valve assembly (8) in a convenient location. Place the bundle or items to be cable tied in the open jaws of the tool and depress the foot valve until the cable tie is applied, tensioned and cut off. Move the bundle or item to the next desired cable tie location and repeat as necessary. Refer to the PAT1M/PAT1.5M Operation Manual for further operation, maintenance and technical information.



CAUTION: DO NOT insert fingers in between the jaws of the tool.

MOUNTING

Securely fasten the PATMBM Bench Mount Base (6) to a bench or cart using four 5/16" or 8M screws. Use mounting template below (not to scale) for hole layout.

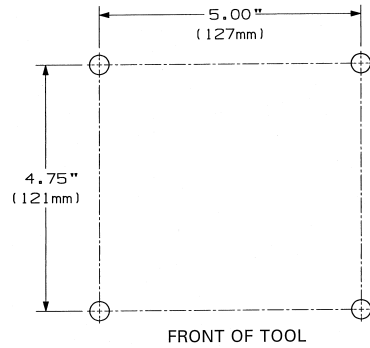

ALTERNATE ASSEMBLY / INSTALLATION

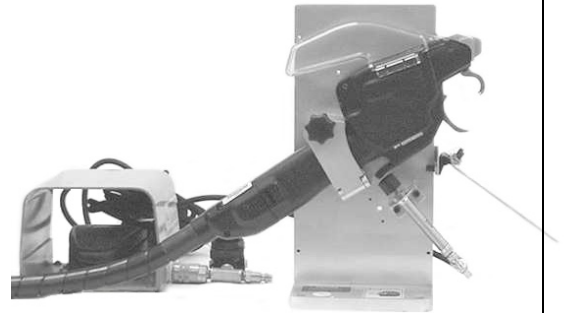
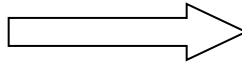
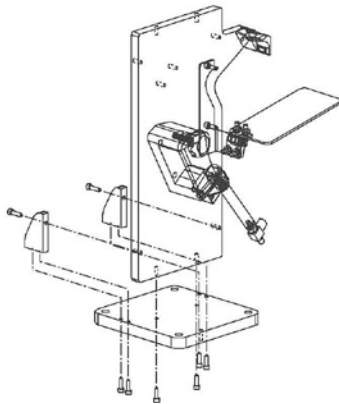

Note: It is recommended that the entire PAT1M / PAT1.5M system be configured in the orientation shown.

