

**ES2P Intelligent PDU Installation Manual**  
**V1.1**

## Table of Contents

Before You Begin.....	3
Overview .....	3
Important Safety Information.....	3
Required Tools.....	5
Section 1 – Introduction .....	6
Classification Overview .....	6
Features .....	7
Form Factors .....	8
Load Segment and Phase Distinction.....	8
Section 2 – Installing the PDU .....	9
Vertical PDUs.....	9
Install Mounting Hardware.....	9
Install Bracket Hardware (BRK01 – Optional).....	10
Vertical (0U) PDU– Single Installation .....	11
Vertical (0U) PDU– Two or More Installation .....	11
1U PDUs.....	12
Mounting Hardware Installation .....	12
Grounding the PDU.....	13
Connecting the Ground Bonding Cable .....	13
Bonding .....	14
Section 3 – Connecting the PDU .....	15
Connecting the PDU to a Power Source .....	15

# Before You Begin

## Overview

This document provides installation instructions and configuration instructions to qualified personnel for installing a Panduit Metered, Switched, and Metered & Switched Power Distribution Unit (PDU) into a datacenter rack. Please read all instructions before operating the equipment and save this manual for future reference.

## Important Safety Information

See the complete regulatory compliance notices in Safety and Compliance Information for Server, Storage, Power, Networking, and Rack Products on the Panduit website (<http://www.panduit.com/>). In addition, follow the safety precautions that are specific to this device.

This PDU is intended only for Information Technology Equipment (ITE) loads with linear/Power Factor Corrected (PFC) input current. If non-linear loads are connected, the nameplate current rating of the PDU must be reduced by a factor of 0.8.

- 
- ⚠ **WARNING:** A risk of personal injury from electric shock and hazardous energy levels exists. The installation of options and routine maintenance and service of this product must be performed by individuals who are knowledgeable about the procedures, precautions, and hazards associated with AC power products.
- 

### **IMPORTANT SAFETY INSTRUCTIONS-----SAVE THESE INSTRUCTIONS**

---

Follow these safety precautions when connecting multiple hardware components to power sources

- 
- ⚠ **WARNING:** To reduce the risk of fire, electric shock and damage to the equipment:

**HIGH LEAKAGE CURRENT.** To reduce the risk of electric shock due to high leakage currents, ensure that there is a reliable grounded (earthed) connection before connecting power distribution products to AC power. If a

---

Large number of products will be connected to a single PDU, it may be necessary to conduct an evaluation of the installation to verify the total amount of leakage current. The total combined leakage current should not exceed 5 percent of the input current for the PDU and associated load.

---

Connect only to a circuit providing branch circuit overcurrent protection of appropriate current rating.

Connect the input power cord to a grounded (earthed) electrical outlet that is located near the equipment and is easily accessible.

Be sure all circuit breakers are in the off position before connecting input power.

Be sure that the devices connected to the Panduit PDU are adjusted for, or otherwise capable of, operation from the same line voltage supplying the PDU. Failure to verify the voltage can lead to severe equipment damage.

Do not overload the PDU. The total input current rating of all equipment connected to each output cannot exceed the total output rating marked on the PDU.

Use only the hardware provided to install the PDU.

To reduce the risk of fire or electric shock, install this PDU in a temperature and humidity controlled, indoor environment, free of conductive contaminants.

Do not operate near water or excessive humidity (90% maximum noncondensing).

Ambient temperature must not exceed 0°C to 60°C (32°F to 140°F).

The internal components can become extremely hot during operation. Allow sufficient time for the PDU to cool before handling.

Do not use a two-wire power cord in any product configuration.

**TO ISOLATE THIS EQUIPMENT, DISCONNECT THE POWER CORD.**

---

**DANGER:** This PDU contains **LETHAL VOLTAGES**. **NO** repairs should be performed on these units except for the replacement of the management card. There are **NO USER SERVICEABLE PARTS** inside the PDU. The installation of options, routine maintenance, and service of this product must be performed by individuals who are knowledgeable about the procedures, precautions, and hazards associated with AC power products.

**IT IS ESSENTIAL THAT THIS EQUIPMENT IS CONNECTED TO AN ELECTRICAL SUPPLY.**

---

For permanently connected PDUs, the installation must be performed by a licensed electrician, must be connected to an AC power source that is current limited by a properly rated circuit breaker or fuse meeting national and local electrical codes, and must be connected to a protective earth ground.

## Required Tools

The following tools maybe required for installation:

- . Phillips screwdriver
- . Torx screwdriver

# Section 1 – Introduction

## Classification Overview

Panduit intelligent Power Distributions Units(PDU) are designed to distribute power to IT equipment installed into a rack. These PDUs are single-phase (1Ph) or three-phase (3Ph) models with electrical metering and switching capabilities.

Each PDU provides power distribution to IT loads through C13, C19 outlets. The quantity and location of outlets vary by model. The PDUs allow you to connect and manage these outlets from a single power connection. The PDUs can be managed from a Web interface, or a Command Line Interface (CLI), and viewed from the local display.

Panduit PDUs are designed for use with all Panduit cabinets and are compatible with most third-party data center racks. The PDU models vary in form factor with several mounting configurations available.

**Panduit Monitored PDU:** Provides aggregate power monitoring to quickly identify potential power issues and reclaim available or under-utilized power capacity.

**Panduit Switched PDU:** Provides aggregate power monitoring and outlet level switching capabilities for individual outlets or a group of outlets. This PDU enables power sequencing, rebooting equipment or restrict unauthorized use of individual outlets.

**Panduit Monitored per Outlet PDU:** Provides outlet-level power monitoring to quickly identify potential power issues and reclaim available or under-utilized power capacity at the outlet level.

**Panduit Monitored & Switched per Outlet PDU:** Provides outlet-level power monitoring and outlet-level switching capabilities for individual outlets or a group of outlets. Power monitoring at the individual outlet level provides actionable management data on the power consumption of each connected IT device, enabling the redeployment or decommissioning of individual servers to reclaim available or under- utilized power capacity.

## Features

The Panduit Monitored, Switched, Monitored per Outlet, and Monitored & Switched PDUs provide the following features:

- **Lower profile on Vertical PDUs** – enhances serviceability area in the back of the rack.
- **Multiple mounting options on Vertical PDUs** – can be mounted with outlets facing in toward center of rack, back or front of rack.
- **Higher operating temperature** – all Essential series PDUs rated for 60°C operating temperature.
- **Color-coded outlets to circuit breakers** – used to easily differentiate load segments and phases
- **1U PDUs support multiple mounting options** – can be mounted horizontal in a U space or in the True 0U space between the RETMA rails.
- **Hot Swappable Network Management Module** – allows power distribution during module replacement eliminating downtime.
- **10/100 Ethernet** – eliminates the need to manually set the network switch to run at a slower rate
- **Daisy Chain** – able to network up to sixteen of the same PDUs on one IP address.
- **Enhanced Sensor Support** – supports up to 2 physical sensors and four measurements per PDU with a total of 128 measurements in a maximum daisy chain configuration.
- **Highly Visible LCD display** – improves visibility while providing local access to view configuration setting. Automatically enters sleep mode to conserve energy and protect the display from burn in.

## Form Factors

Details of the form factors that are covered within this document.

Form Factor	Details
0U (Vertical)	Vertical PDUs come in Half, Mid, & Full-height versions and install vertically in the 0U space in the back of the rack. There are also Half and Full-height dual sided models that install vertically in the 0U space in the back of the rack.
1U	1U PDUs can be installed in a U position in the rack, or in the true 0U space on the side of the rack between the RETMA rails.

## Load Segment and Phase Distinction

Panduit Essential PDUs have colored receptacles to help distinguish between the different load segments and phases. All Panduit three phase PDUs have different colored receptacles (white, dark gray, and black) to distinguish the different phases. All Panduit PDUs with breakers have different colored receptacles to distinguish the different load segments (with one exception as noted below). For single phase PDUs with no breakers the receptacles are all black.

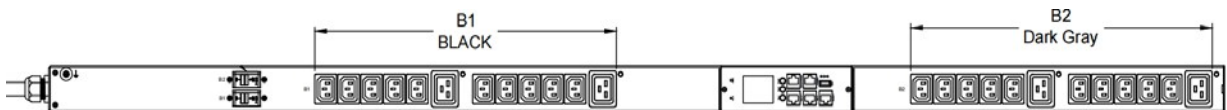

**Single Phase PDU Example**



**Three Phase PDU Example**



## Section 2 – Installing the PDU

### Vertical PDUs

Panduit Vertical PDUs include the following form factors: half-height, mid-height, and full-height models. This section covers the recommended installation methods

#### Install Mounting Hardware

Each vertical PDU has two mounting hole locations on the back of the PDU for the button installation to assist with mounting in a non-Panduit racks. When installing the mounting buttons, use either mounting hole as a set.

#### Mounting Button Installation – Outlets Facing the Center of the Rack

1. Align and install the mounting buttons with the screw holes on the face, opposite of the receptacles.

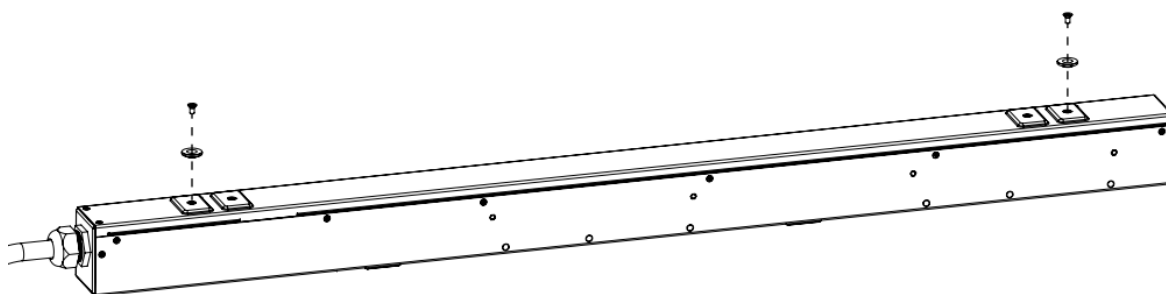

2. Install the PDU by inserting the mounting buttons into the keyhole slots on the PDU mounting bracket in the rack.

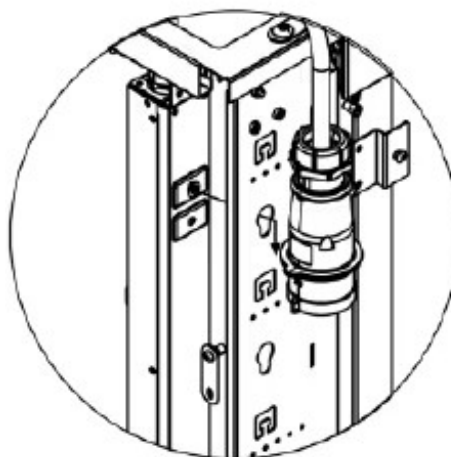

### Install Bracket Hardware (BRK01 – Optional)

Each vertical PDU can install the optional bracket (BRK01) on the end of the PDU when non-condition for installing the mounting buttons.

#### Bracket Installation – Outlets Facing the Center of the Rack

Each vertical PDU can install the optional bracket with provided screws on the end of the PDU.

1. Align and install the bracket with the screw holes on the end of PDU, fix with provided screws.

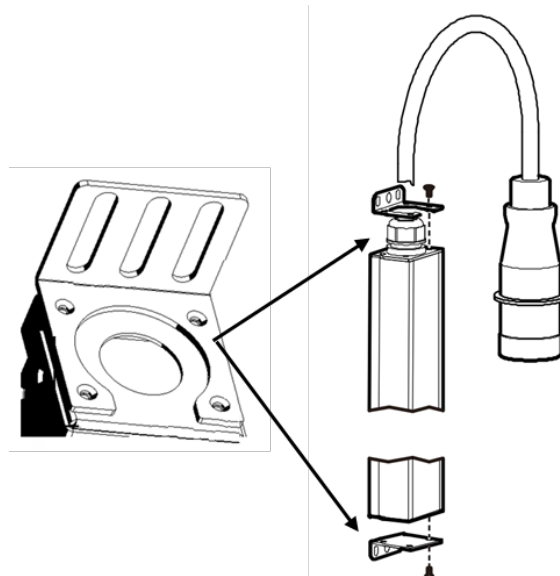

2. Install to the rack with provided four (4) M5x10mm self-tapping screws.

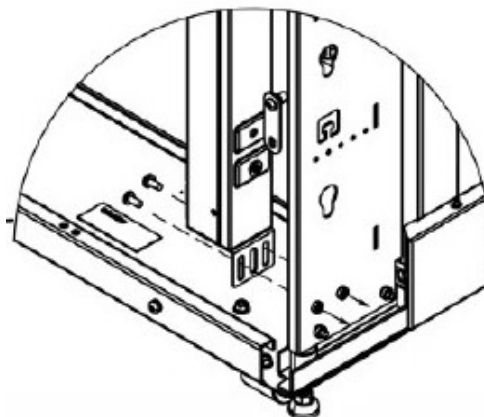

### Vertical (0U) PDU– Single Installation

A single vertical unit can be installed with the outlets facing the center (A) The pictures below illustrate these installation methods.

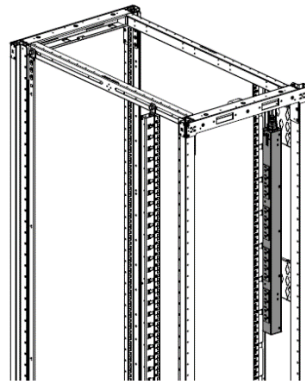

(A)

**NOTE:** The above installation methods are true for all vertical models. Those units can only mount on its side with outlets facing the back of the rack.

### Vertical (0U) PDU– Two or More Installation

For two full-height (in a 42U/45U/48U rack), two mid-height (in a 42U/45U/48U rack), or four half-height (in a 42U/45U/48U rack) vertical units to be mounted on one side of the rack, all units must be installed with the outlets facing in towards the center of the rack.

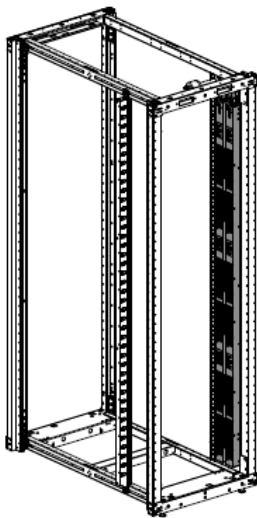

(A)

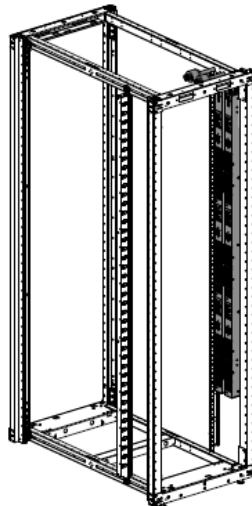

(B)

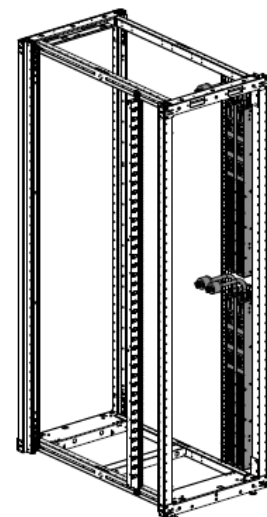

(C)

**NOTE:** (A) Two full-height PDUs with outlets facing in towards the center of the rack;  
 (B) Two mid-height PDUs with outlets facing in towards center of the rack;  
 (C) Four half- height PDUs with outlets facing in towards center of the rack.

## 1U PDUs

### Mounting Hardware Installation

#### 1U PDU Mounting in a U Position of the Rack

1. Install the cage nuts at the desired U location.

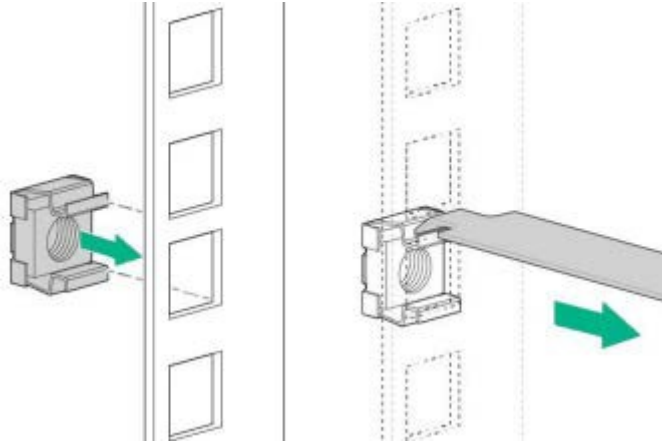

2. Screw the mounting bracket ears into the RETMA rail surface at the U location where the cage nuts were installed.

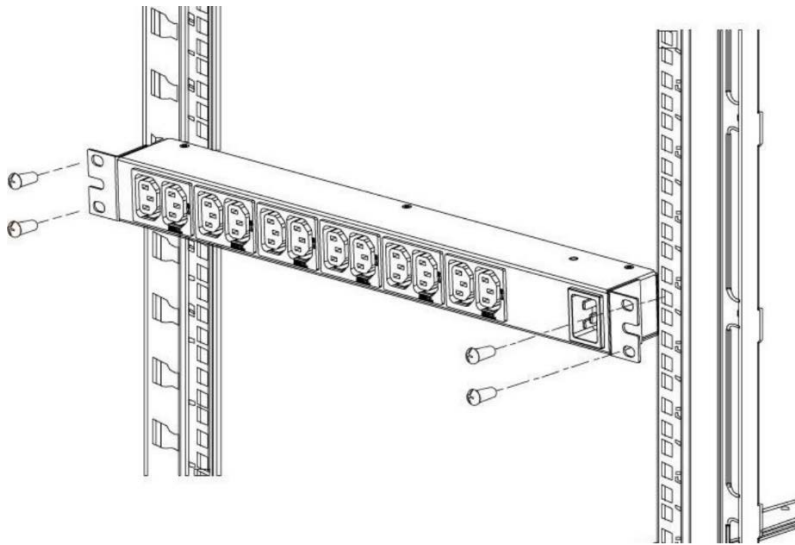

## Grounding the PDU

### Connecting the Ground Bonding Cable

Per international regulatory requirements, the primary Safety Earth Bond connection is

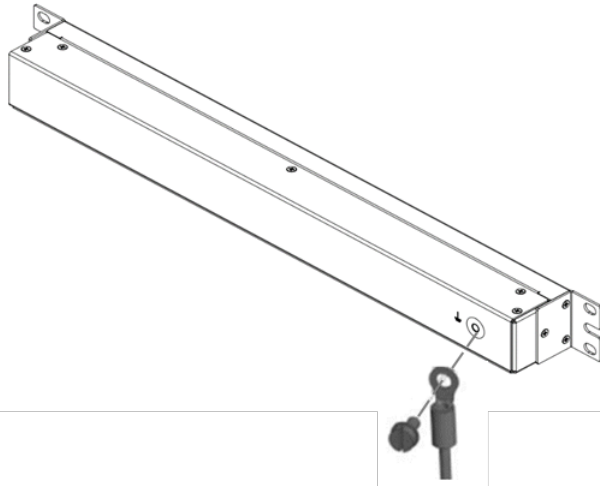

contained in the PDU as an integral part of the branch circuit cabling and plug. There is an external ground bonding point located on the chassis of the PDU. The ground bonding screw is provided as an attachment point for conductors. Use a ground bonding cable if the rack contains any conductors for functional grounding or bonding of ungrounded metal parts. This bonding point can also be used to bond the PDU to a known earthed reference terminal in the building. The ground bonding point is located on the surface with the receptacles on all PDUs except for the dual-sided models. These models have the ground bonding point on the surface with the circuit breakers.

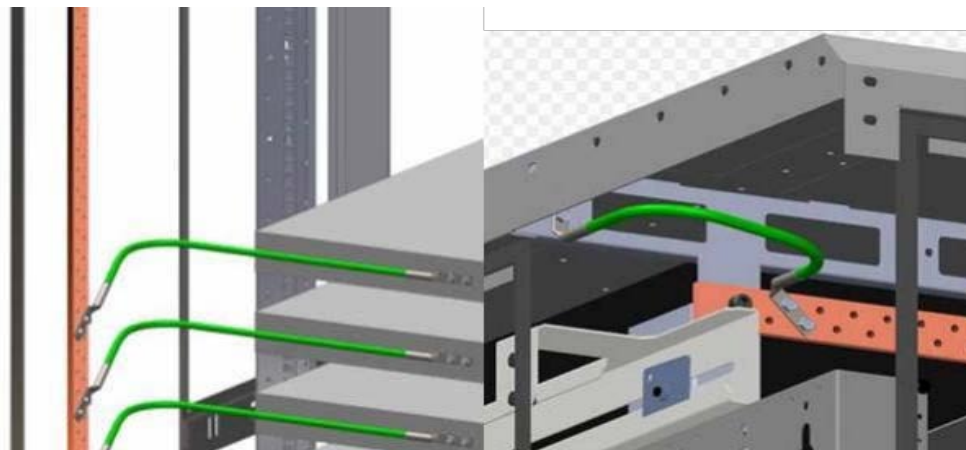

Bond Power Distribution Units (PDUs) to grounding strip or grounding bus bar. See **Panduit Grounding and Bonding Jumper kits** for factory terminated options to provide a bolt-on solution.

## Bonding

This product contains an external earthing screw with a star washer, which should be used for supplementary Earth bonding to the rack metalwork.

Bonding	
Minimum Requirements for Bonding Conductors	
Up to and including 32A	12 AWG
Screw Size	
Over 16A, less than or equal to 40A	5mm

## Section 3 – Connecting the PDU

### Connecting the PDU to a Power Source

Always follow local and national codes when installing the PDU. The PDU should be connected to a dedicated circuit protected by a branch circuit breaker matching the PDU input plug type.

**NOTE:** When connecting the PDU to a Power Source, make sure that you have enough length in the PDU power cord to reach the PDU power source.

1. Turn the feed circuit breaker Off.
2. Make sure that all circuit breakers on the PDU are set to On.
3. Connect each PDU to an appropriately rated branch circuit.

**NOTE:** Refer to the label on the PDU for the input ratings.

4. Turn the feed circuit breaker On. The LCD screen (on units with display) will display a status bar when the PDU operating system is loading. When complete, the Main Menu will display on the LCD screen. Switched and Monitored & switched PDUs show a light corresponding to each outlet as it is powered up.