

THIS COPY IS PROVIDED ON A RESTRICTED BASIS AND IS NOT TO BE USED IN ANY WAY DETRIMENTAL TO THE INTERESTS OF PANDUIT CORP.

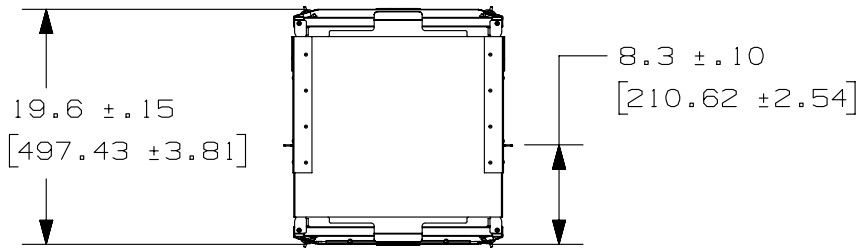

PANDUIT PART NO.	PART WEIGHT
FRME22U	65 LBS/EACH 29.5 KG/EACH

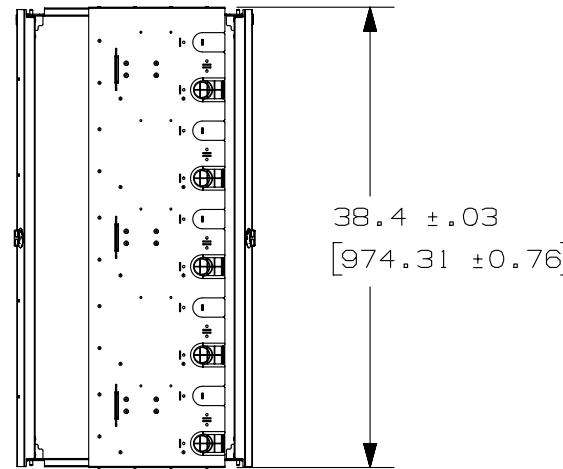
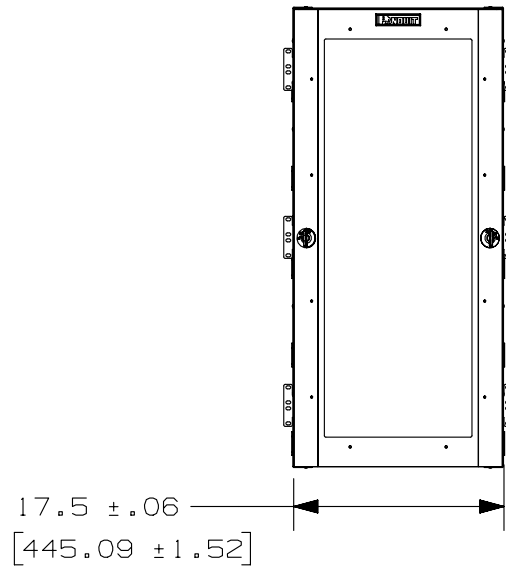

CLEAR POLYCARBONATE WINDOW

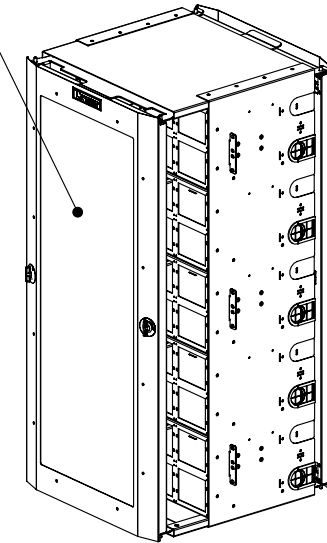

REV	DATE	BY	CHK	APR	DESCRIPTION	ECN
00	01-12-15	SAT	JESA	TMK	RELEASED TO PRODUCTION	11F148AK-DC

TITLE		RACK MOUNT PATCH BAY ENCLOSURE		
		CUSTOMER DRAWING		
ITEM REVISION NAME		11F148AK/01		
DATASET FILE NAME		11F148AK_DC/01B		
UNLESS OTHERWISE SPECIFIED, DIMENSIONAL TOLERANCES ARE: IN (mm)				
.x ± .xx ± .03 (0.8) .xxx ± .010 (0.3) ANGLES ±				
DRAWN BY		DATE	CHK	SCALE
SAT		01-12-15	JESA	NONE
PART NO.		FRME22U		
DRAWING NUMBER:		11F148AK-DC		
SHT 1 OF 1		A		

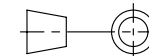

THIRD ANGLE PROJECTION