

THIS COPY IS PROVIDED ON A RESTRICTED BASIS AND IS NOT TO BE USED IN ANY WAY DETRIMENTAL TO THE INTERESTS OF PANDUIT CORP.

PANDUIT P/N	WEIGHT
PWBTSBEZ	.065 LBS/EACH (29.5g)/EACH

NOTES:

1. VISIT OUR ON-LINE CATALOG AT WWW.PANDUIT.COM FOR A LIST OF CURRENT PARTS APPLICABLE FOR USE WITH THIS PRODUCT.
2. DIMENSIONS IN [] ARE METRIC.
3. ALL MATERIALS AND COMPONENTS USED MEET THE MATERIAL RESTRICTIONS OF RoHS (EUROPEAN DIRECTIVE 2011/65/EU ON THE RESTRICTION OF HAZARDOUS SUBSTANCES) AS PROPOSED BY THE RoHS TECHNICAL ADAPTATION COMMITTEE.
4. REQUIRES CUSTOMER SUPPLIED 1/2" OR 12mm THREADED ROD AND HARDWARE TO MOUNT.
5. USE THREADED ROD COVER (TRC18FR-X20Y) IN APPLICATIONS WHERE CABLING IS EXPOSED TO THREADED ROD.
6. PART INCLUDES: 50 TRAPEZE SUPPORT BRACKET

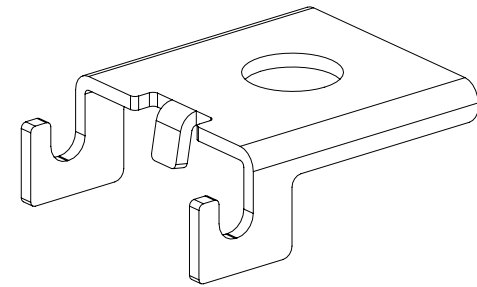
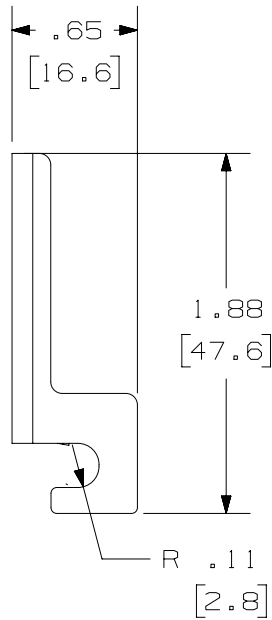
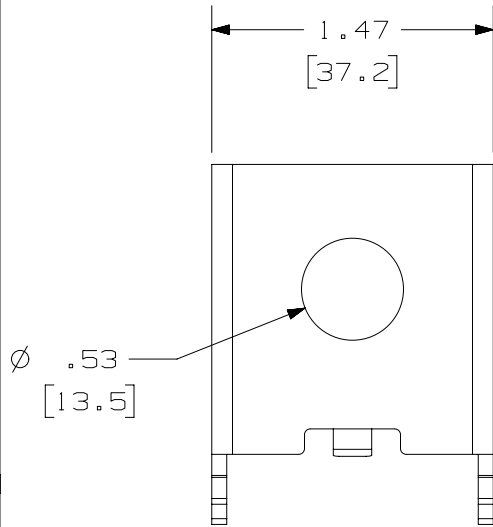

REV	DATE	BY	CHK	APR	DESCRIPTION	ECN
02C	12-14-23	SAT	DWR	EB	B. UPDATED TITLE.	00510JBH-DS
06B	3/15/22	JSP	DWR	ML	A. UPDATED NOTES	00510JBH-DS
00A	3/1/21	JSP	DWW	ML	INITIAL RELEASE	00510JBH-DS

TITLE WIRE BASKET TRAPEZE HANGER BRACKET (PACK OF 50)						CUSTOMER DRAWING	
ITEM REVISION NAME 00510JBH/02						PANDUIT	
DATASET FILE NAME 00510JBH_DC/02C							
MATERIAL CLEAR ZINC PLATED C.R.S.				DRAWING NUMBER 00510JBH-DC		THIRD ANGLE PROJECTION	
DRAWN BY JSP	DATE 3/1/21	CHK DWW	SCALE NONE	SHEET 1 OF 1		SIZE A	