

THIS COPY IS PROVIDED ON A RESTRICTED BASIS AND IS NOT TO BE USED IN ANY WAY DETRIMENTAL TO THE INTERESTS OF PANDUIT CORP.

Material	High Conductivity Seamless Copper Tube
Plating	Min .000050" Nickel underplate, Min .000200" Silver plating
Wire Size	8 AWG
Wire Type	Stranded Copper; Class B: Compact, Compressed or Concentric, Class C: Concentric
Wire Strip Length	5/8 in.
Stud Size	1/4 in.
UL Listed Wire Connector	Yes, for applications up to 35kv. Consult cable manufacturer for voltage stress relief instructions with applications greater than 2000 volts.
UL Temperature Rating	90° C
C.S.A Certified Wire Connector	N/A
Panduit Color Code on Barrel	RED
Panduit Die Index No. on Barrel	P21
Alternate Industry Die Index No. ( ) on Barrel	N/A

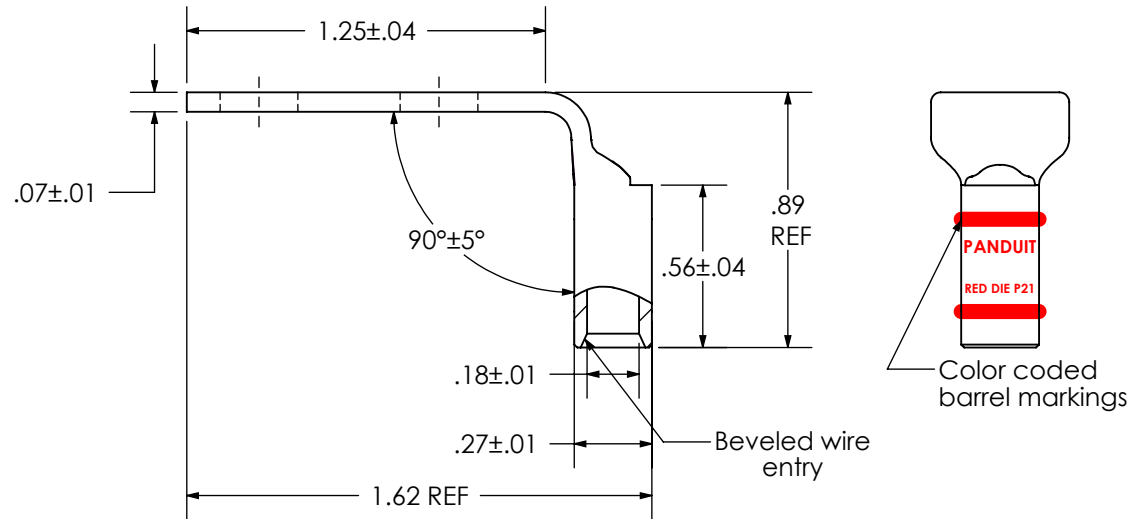
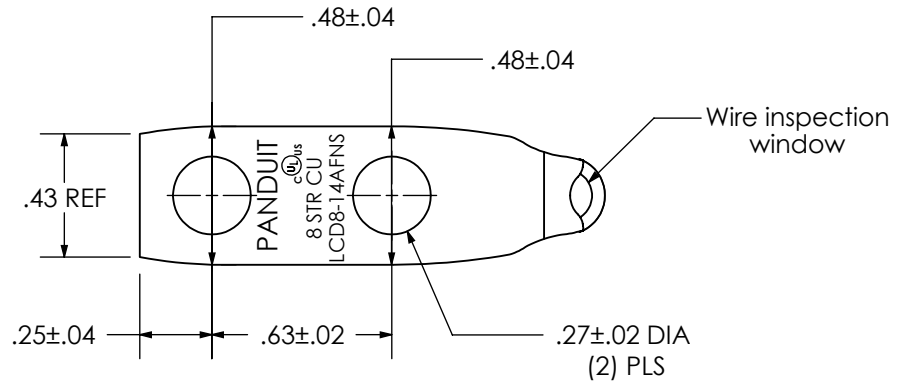

NOTE: DIMENSIONS AND TOLERANCES ARE IN INCHES

**PANDUIT CORP.** TINLEY PARK, ILLINOIS

LCD8-14AFNS-L  
Copper Lug - Two-Hole, Standard Barrel, 90° Angle Tongue

06	6-23	JHNU	DAEI	MRWA	B. REVISED TONGUE SHAPE A. ADDED TONGUE WIDTH DIMENSIONS	129336
REV	DATE	BY	CHK	APP	DESCRIPTION	ECN

SCALE	N/A	DRAWING NO / CAD FILE	LCD8-14AFNS-CUST
-------	-----	-----------------------	------------------