

IMPORTANT SAFETY INFORMATION REGARDING PANDUIT VERISAFE ABSENCE OF VOLTAGE TESTER

VeriSafe AVT Models VS-AVT-C02-L03, VS-AVT-C02-L10, VS-AVT-C08-L10, VS-AVT-RKBB2, VS-AVT-RKBB3, VS-AVT-RKBB4

The VeriSafe AVT [Instruction Manual](#) is being updated to provide additional important safety information. Panduit was recently made aware of a potential connection scheme with the VeriSafe AVT **that could result in the VeriSafe AVT showing a green absence of voltage, when in fact voltage is present.** This would only occur if the sensor leads were not properly terminated and secured. While the probability of this happening is low, Panduit strongly recommends following some simple mitigation techniques to significantly reduce the likelihood of such failure.



Warning: Please take time to read and follow the mitigation steps on any installed (or to be installed) VeriSafe AVT at your facility. Failure to perform the recommended mitigation techniques set forth in this document could result in injury, including death.

This notice applies to VeriSafe AVT units with QC numbers less than 678208002.

Sensor Leads & Connectivity Test

The VeriSafe AVT is designed with two sensor leads for each phase conductor. The two leads in each set have different functions: one lead is used to detect voltage (detection lead) and the other lead is used to verify that the detection lead is in contact with a conductor (termination lead). The termination lead does not detect voltage. There are no labels distinguishing the detection and termination leads for each phase because it is critical that all are properly terminated.

Each time the absence of voltage test is initiated, a “connectivity test” occurs to ensure that each detection lead is in contact with a conductor. If the connectivity test fails on any detection lead, the green absence of voltage indicator on the AVT will not illuminate.

Potential Installation Issue

If a detection lead is not properly terminated to a power conductor *and* comes in contact with a low impedance path to ground, the connectivity test could pass. **This may result in a green absence of voltage indication, even though the power conductor is energized.** This scenario would require a series of multiple faults, but is possible if terminations are not made properly and secured.

This is primarily a concern on single-phase systems since they may only have one detection lead terminated to a current carrying conductor. If the detection lead were to become loose and make contact with a low impedance path to ground, the connectivity test would pass. However, voltage would not be detected because the termination lead does not detect voltage and the detection lead is no longer in contact with the power conductor. Therefore, the device could indicate there is no voltage present when in fact there is voltage.

In the case of split-phase or three-phase systems, this condition is not likely to occur as *all* detection lead terminations would need to fail *and* each detection lead would have to make contact with a low impedance path to ground at the time of the test. However, even the loss of a single detection lead termination on a multi-phase system could result in the scenario described above, if voltage was only present on a single phase.

There is a Commissioning Checklist in the Instruction Manual that, if followed correctly, will verify proper function at the time of installation. Utilization of the commissioning test described in the Instruction Manual, will verify proper functionality of the AVT at the time of installation and calls attention to inspecting terminations. The failure modes described in this section would be the result of sensor lead terminations not being maintained over time and sensor leads not being secured to the power conductors at time of installation.

The likelihood of this scenario occurring can be prevented by using the mitigation techniques described in this notice.

Mitigation Technique 1

Securing the sensor leads to the power conductor or another nearby rigid feature would prevent movement in the event that the termination point failed, significantly reducing the likelihood of that detection lead contacting ground. Sensor Leads can be secured using cable ties, clamps, mounts, or tape. The sensor leads should be secured at multiple locations, including near the termination point. This best practice is illustrated in Figure 1 and should be followed for all VeriSafe AVT installations.

In addition, the sensor lead terminations should be inspected periodically, similar to other critical terminations inside an electrical enclosure, to ensure they are tight and the sensor leads are secure.



Figure 1: Sensor leads are secured with cable ties near the termination point

Mitigation Technique 2

In a single-phase installation, two sets of sensor leads can be terminated to the power conductor and one to the neutral line (see Figure 2). Using this wiring method creates a redundant detection lead and provides an additional reliability. With this method, if a detection lead was to separate from the termination point on an energized power conductor *and* contact a low impedance path to ground, there would still be a second detection lead on that power conductor to detect any voltage that may be present. This is an optional connection method that may be utilized in addition to securing the sensor leads.

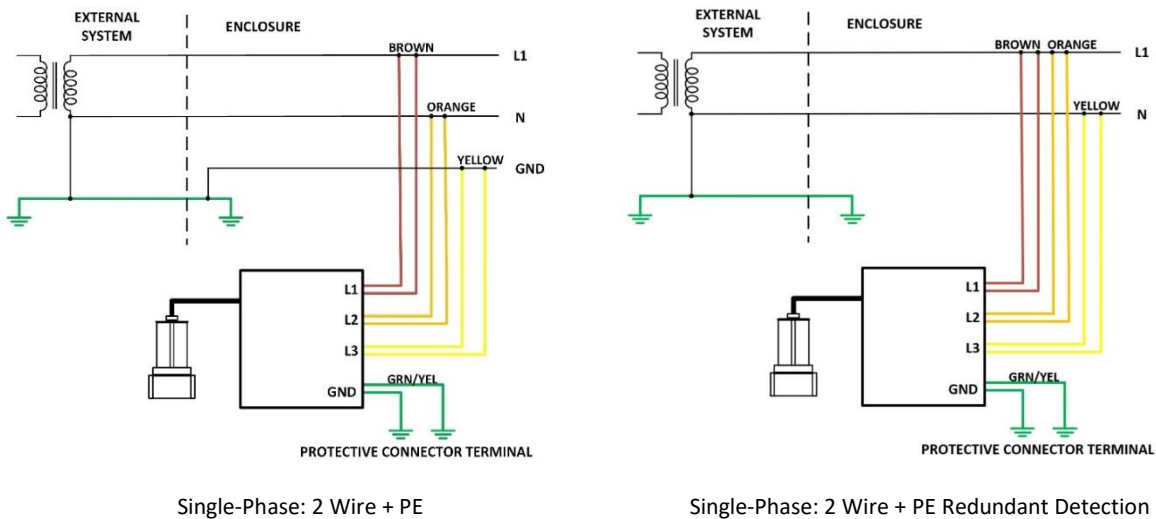

Figure 2: Options for wiring the AVT in a single-phase system

Summary

The VeriSafe AVT [Instruction Manual](#) (B21052–English; B21053–Français; B21057–Español) is being updated to provide a better explanation of the sensor lead function and potential for this scenario, along with the mitigation techniques described in this notice. Please use revision 03 or greater of the [Instruction Manual](#). The current revision can be found at http://www.panduit.com/verisafe/VeriSafe_Manual_EN. VeriSafe AVT units with QC numbers greater than 678208002 will include the revised Instruction Manual.

The VeriSafe AVT verifies the absence of voltage before equipment is accessed, allowing qualified electrical workers to confirm an electrically safe work condition without exposure to electrical hazards in a fraction of the time required when using a hand-held tester. This product was developed within the strict analysis and reliability requirements of SIL 3 in accordance with the IEC61508 standard. Panduit is committed to the safety of our customers and communicating any new information that will help them install and use this products in the safest way possible.