

Wire Basket

Overhead Cable Tray
Routing System

PANDUIT[®]

Application Guide

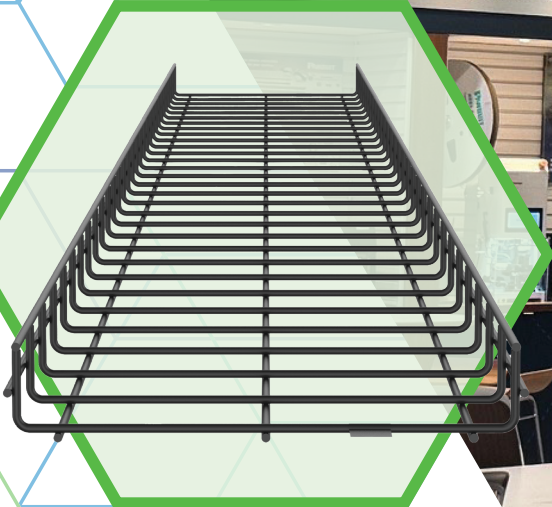
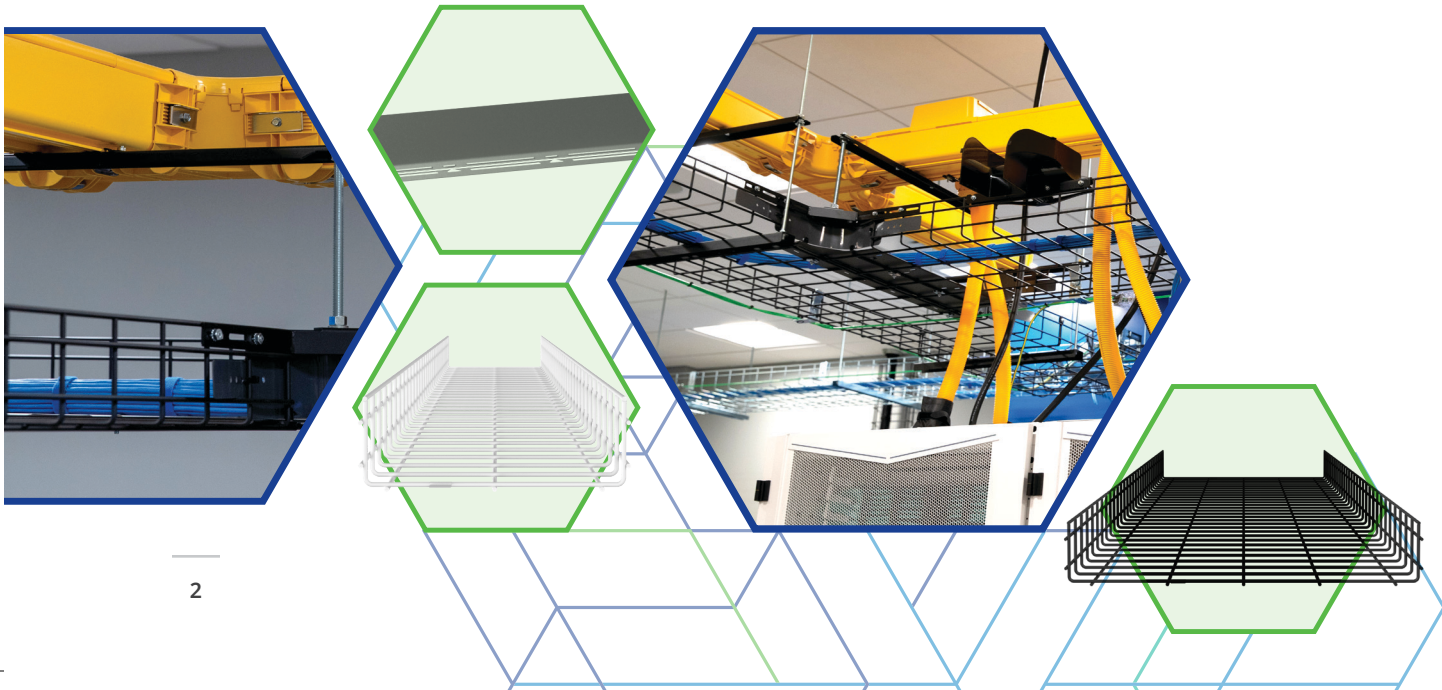

Table of Contents

Introduction	3
Pathways and Accessories.....	3
Application.....	4
Pathway Sections.....	5
Loading and Fill Areas	7
Tee Intersection Options	9
Vertical Level Changes	10
Horizontal Sweeping Bends	10
Mounting Details	12
Cable Exit Accessories.....	15
Accessories	16
Tray Liners and Divider Walls.....	17
Metal Covers and Cover Retention Straps.....	18
Color and Finish Specifications	19
Grounding and Bonding	20
Safety	22
Best Practices.....	23
Commitment to Sustainability.....	24
Design Tools for Wire Basket Overhead Cable Tray Routing System.....	25



Introduction

With data centers, commercial real estate, and industrial facilities evolving to meet the challenges of complex architectures, new technologies and increasing performance requirements, a robust physical infrastructure is needed to provide operational benefits to drive business results. Cable management is a crucial consideration of the physical infrastructure for optimizing system reliability, effective space utilization, and scalability. Panduit offers industry-leading cable routing systems as part of comprehensive, integrated data center solutions to effectively manage and protect high-performance communication, computing, and power cables. Wire Basket Overhead Cable Tray Routing System contributes to effective space utilization and network performance, and it provides speed of deployment, structural integrity, cable protection, and ease of use.

System Overview

The Wire Basket Overhead Cable Tray Routing System is composed of pathways, splices, mounting brackets, and accessories that allow the system to be configured for a wide range of applications and installed into virtually any enterprise, data center, or telco room application.

Pathways and Accessories

Wire Basket pathway sections are a welded steel mesh design that provides a high strength-to-weight ratio and are assembled via various splices, mounting brackets, and accessories. Integrated sidewalls allow for the containment of a high volume of cabling bundles.

The system is offered in three finishes – powdered coat (in black or white) and electro zinc – that provide the required level of corrosion resistance for data center and enterprise applications.

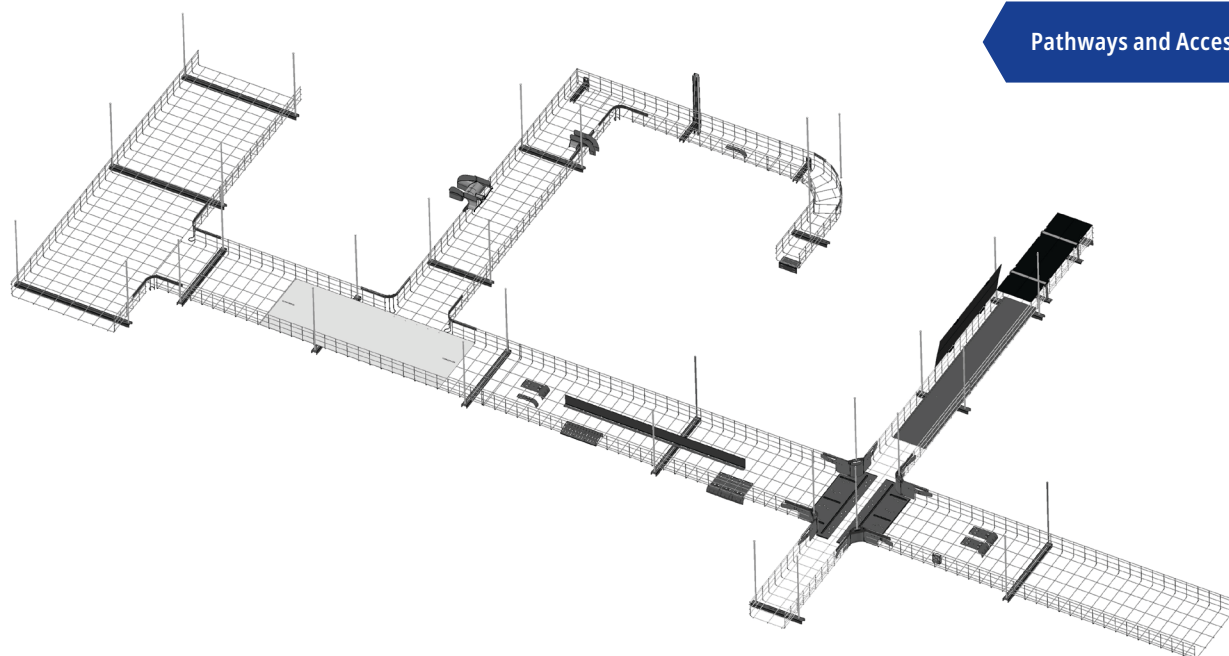

Application

The wire basket can be mounted in many different applications. The basket is very versatile and very few pieces are needed to complete various elevation changing. Because of it's versatility, it makes it very easy to be placed in various environments.

► **Industry Automation**

- Warehousing
- Manufacturing

► **Technology and Automation**

- Data Center/Colocation
- Education
- Enterprise
- Financial Institutions
- Medical
- Telecommunications

► **Logistics and Infrastructure**

- Airports
- Commercial/Retail
- Material Handling



Pathway Sections

Part Number	Height In. (mm)	Width In. (mm)	Length In. (mm)	Weight lbs. (kg)
PWB2X4**	2.43(61.6)	4.63 (117.7)	118.33 (3005.6)	14.0 (6.35)
PWB4X4**	4.43 (112.4)			10.0 (4.581)
PWB2X6**	6.43 (163.2)	6.63 (168.4)		10.8 (4.899)
PWB4X6**	4.43 (112.4)			14.5 (6.577)
PWB6X6**	6.43 (163.2)			18.5 (8.391)
PWB2X8**	2.43 (61.6)	8.63 (219.3)		11.5 (5.216)
PWB4X8**	4.43 (112.4)			15.2 (6.895)
PWB6X8**	6.43 (163.2)			19.2 (8.709)
PWB2X12**	2.43 (61.6)	12.63 (320.9)		14.1 (6.396)
PWB4X12**	4.43 (112.4)			17.9 (8.119)
PWB6X12**	6.43 (163.2)			21.8 (9.888)
PWB2X18**	2.43 (61.6)	18.63 (473.3)		17.3 (7.847)
PWB4X18**	4.43 (112.4)			21.2 (9.616)
PWB6X18**	6.43 (163.2)			25.0 (11.340)
PWB2X24**	2.43 (61.6)	24.63 (625.7)		20.6 (9.344)
PWB4X24**	4.43 (112.4)			24.5 (11.113)
PWB6X24**	6.43 (163.2)			28.2 (12.791)
PWB2X30**	2.43 (61.6)	30.63 (778.1)		23.9 (10.840)
PWB4X30**	4.43 (112.4)		27.8 (12.609)	
PWB6X30**	6.43 (163.2)		31.4 (14.243)	
PWB2X36**	2.43 (61.6)	36.63 (930.5)	26.8 (12.156)	
PWB4X36**	4.43 (112.4)		30.7 (13.925)	
PWB6X36**	6.43 (163.2)		34.6 (15.964)	

NOTE: Replace ** With Color/Coating Option
 BL = Black Powder Coated
 WH = White Powder Coated
 EZ = Electro Zinc
 Ex: PWB2X4WH = 2" H x 4" W White Powder Coated Basket

3 Pathway Heights

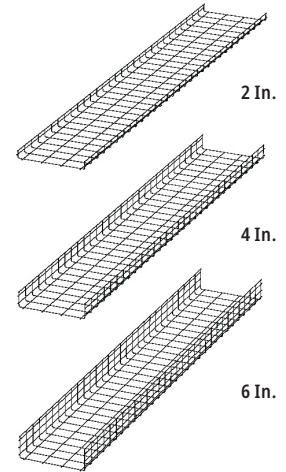

8 Pathway Widths

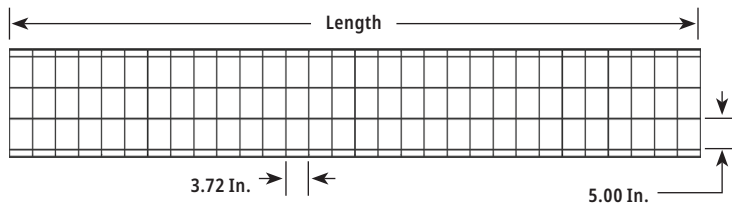
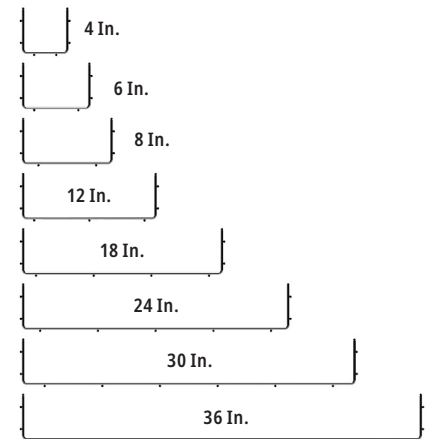

Wire Basket Hardware Kits are used to secure basket sections to flat mounting surfaces on support brackets, intersection bend fittings, and flat expansion bar accessories. Bolted splices are used for end-to-end pathway connections and to physically attach mating bottom surfaces at fabricated intersections.



PWBHK -L**
Hardware Kit
(Std. Pkg Qty = 50)



PWBSPL -L**
Bolted Style Splice
(Std. Pkg Qty = 50)

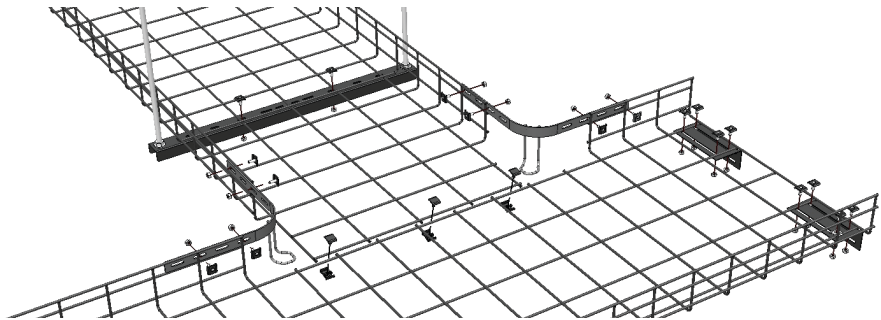

Pathway Width	Splices Required
4 In.	3
6 In.	3
8 In.	3
12 In.	4
18 In.	4
24 In.	4
30 In.	5
36 In.	6

Wire Basket offers simplified splice options that meet the most demanding project requirements. Bolt-on splices firmly secure adjacent pathway sections and can form a UL Classified bond when installed as instructed. Innovative push-on splices offer faster installation without tools and flat expansion splice bars connect gaps between pathways and form in-line pathway width reductions.

PWBSPLBL and PWBSPLEZ:

The Wire Basket Bolted Style Splice is available in black and electro zinc plated finish. This splice can be used to obtain a UL classified bond when properly applied over bare metal surfaces.

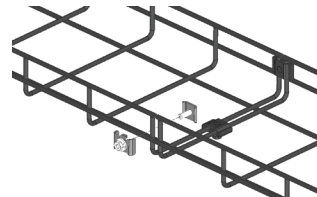

PWBPSBL and PWBPEZ:

The push-on style splice quickly forms end-to-end connections without tools in applications that do not require the splice to form an electrical bond between pathway sections. It is available in black powder coat and electro zinc finishes.

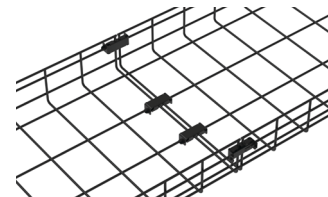
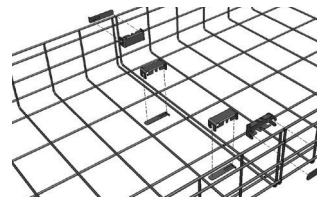

PWBFESBL and PWBFEZ:

The Flat Expansion Splice Bar can be used to join two pathway sections together in applications where small gaps between horizontal pathways prevent the use of PWBSPL** -L or PWBPS** -L splice components.

The Flat Expansion Splice Bar can also be used to create field fabricated end-to-end width reductions between two pathway sections.

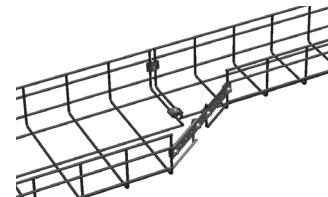
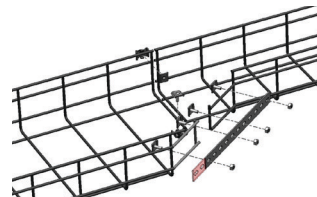
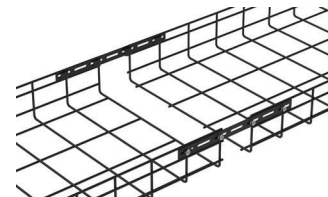
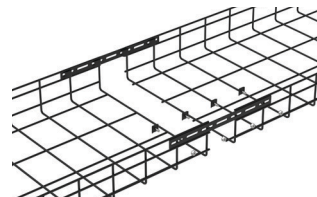

Note: Replace ** with BL for Black or EZ for Electro Zinc

Loading and Fill Areas

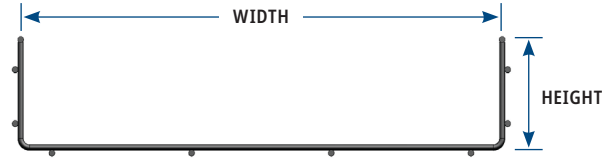

Part Number	Pathway Width In. (mm)	Sidewall Height In. (mm)	Fill Area In. ² (mm ²)	Maximum Cable Fill By Basket Size				
				0.23 In. 5.84mm	0.268 In. 6.81mm	0.32 In. 8.13mm	0.68 In. 17.27mm	0.95 In. 24.13mm
PWB2X4**	4.2 (107.2)	2.0 (50.8)	7.54 (4,864.01)	91	67	47	10	5
PWB2X6**	6.2 (158.0)		11.54 (7,444.65)	139	102	72	16	8
PWB2X8**	8.2 (208.8)		15.54 (10,025.29)	187	138	97	21	11
PWB2X12**	12.2 (310.4)		23.54 (15,186.57)	283	209	146	32	17
PWB2X18**	18.2 (462.8)		35.54 (22,928.49)	428	315	221	49	25
PWB2X24**	24.2 (615.2)		47.54 (30,670.41)	572	421	296	65	34
PWB2X30**	30.2 (767.6)		59.56 (1,512.82)	717	527	370	82	42
PWB2X36**	36.2 (920)		71.56 (1,817.62)	862	634	445	99	50
PWB4X4**	4.2 (107.2)	4 (101.6)	15.1 (9742.19)	182	134	94	21	11
PWB4X6**	6.2 (158.0)		23.1 (14,903.87)	278	205	144	32	16
PWB4X8**	8.2 (208.8)		31.1 (20,065.56)	374	276	193	43	22
PWB4X12**	12.2 (310.4)		47.1 (30,388.93)	567	417	293	65	33
PWB4X18**	18.2 (462.8)		71.1 (45,873.99)	856	630	442	98	50
PWB4X24**	24.2 (615.2)		95.1 (61,354.24)	1,144	843	591	131	67
PWB4X30**	30.2 (767.6)		119.12 (3,025.65)	1,435	1,055	740	164	84
PWB4X36**	36.2 (920)		143.12 (3,635.25)	1,724	1,268	889	197	101
PWB6X6**	6.2 (158.0)	6 (152.4)	34.66 (22,360.45)	417	307	215	48	24
PWB6X8**	8.2 (208.8)		46.66 (30,102.27)	562	414	290	64	33
PWB6X12**	12.2 (310.4)		70.66 (45,585.91)	850	626	439	97	50
PWB6X18**	18.2 (462.8)		106.66 (68,811.37)	1,284	945	663	147	75
PWB6X24**	24.2 (615.2)		142.66 (92,038.54)	1,717	1,264	887	196	101
PWB6X30**	30.2 (767.6)		178.68 (4,538.47)	2,152	1,582	1,110	246	126
PWB6X36**	36.2 (920)		214.68 (5,452.87)	2,585	1,901	1,334	296	151

Note: Replace ** with BL for Black, EZ for Electro Zinc, or WH for White

90 Degree Intersections

Right angle elbow intersections use Radius Intersection 90 Brackets to protect cables transitioning around corners and can be formed from a single pathway or fabricated using the end of two pathway sections.

Add to your BOM:

Part Number	Description	Qty per 90° Int	Std Pkg Qty
PWBIB^**	Radius Intersection Bracket, Set of 2	1 Bracket	1 pkg
PWBHK**-L	Hardware Kit, 50 pcs	4 Pieces	50 pc kit
PWBSPL**-L	Bolt-On Splice, 50 pcs	See Tables Below	
FR716DR	7/16 in. Nut Driver	1 Piece per BOM	1 pc



PWBHK**-L
Hardware Kit
Qty = 4



Fabricated 2-Piece Right Angle Intersections

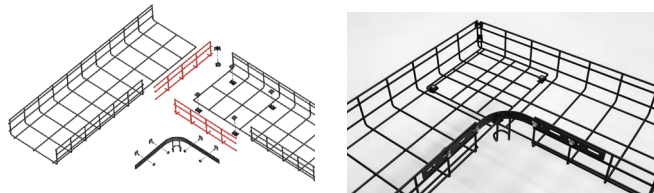

1. Cut away large section of sidewall at end of each of the two pathways
2. Overlap to form 90-degree elbow
3. Secure (1pc) PWBIB^** intersection bend fitting using (4pcs) PWBHK**-L
4. Secure bottom surface and back corner using PWBSPL**-L bolt-on splices
(Reference table to the right)

Fabricated 90° Intersections			
Pathway Width	Sidewall Sections to Remove	Bottom Sections to Remove	PWBSPL**-L Splices on Bottom
4 In.	2	Not Required	1
6 In.	3		3
8 In.	4		5
12 In.	6		
18 In.	7		
24 In.			

Formed Right Angle Intersections

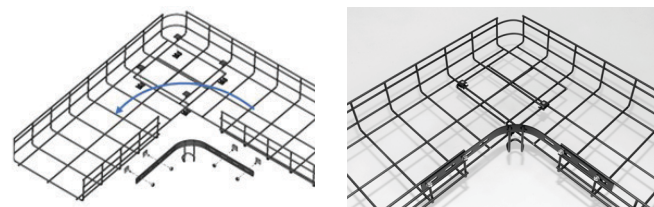

1. Cut away large section of sidewall at least four cross wire sections from the end
2. Cut away one section of bottom pathway wires near middle of area where sidewall section was removed
3. Cut away top wire on the side opposite of where sidewall section was removed
4. Fold pathway on top of itself to form a 90° elbow
5. Secure (1pc) PWBIBx** intersection bend fitting using (4pcs) PWBHK**-L
6. Secure bottom surface and back corner using PWBSPL**-L bolt-on splices
(Reference table to the right)

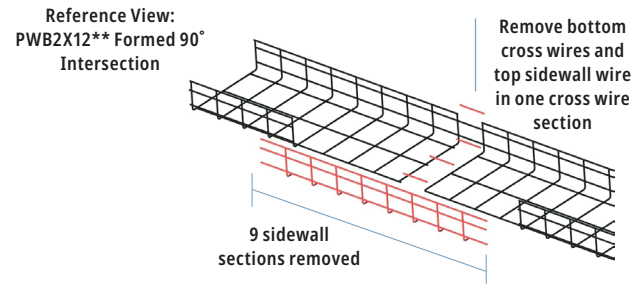

Formed 90° Intersections			
Pathway Width	Sidewall Sections to Remove	Bottom Sections to Remove	PWBSPL**-L Splices on Bottom
4 In.	5	1	0
6 In.			1
8 In.	7		3
12 In.	9		4
18 In.	11		
24 In.	15		

Note: Replace ** with BL for Black, EZ for Electro Zinc, or WH for White
Replace ^ with 2, 4, or 6 sidewall height

Tee Intersection Options

With the Wire Basket, there is the good, better, best package.

Good Option: Tee Build with hardware, PWBSPL**-L

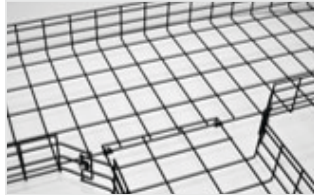

1. Cut the top and sidewalls of the two basket. (Leave one section to bend each ends of the basket)
2. Join the sides and the bottom of the pathway with the bolted splices, PWBSPL**-L.

Better Option: Radius Intersection, PWBIB^**

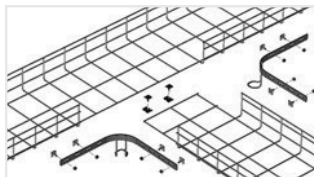

1. The horizontal section of the pathways must have two open spaces on both sides of the sidewall.
2. The vertical pathway must also have two quadrants of the pathway removed.
3. Secure (2 pcs) PWBIB^** intersection bend fitting using (8 pcs) PWBHK**-L
4. Secure bottom surface using PWBSPL** Bolt-on Splices (see table)

Tee Intersections			
Pathway Width	Sidewall Sections to Remove per Pathway	Sections to Remove per Intersecting Pathway	PWBSPL**-L Splices
4 In.	3	1	1
6 In.	4		
8 In.		2	
12 In.	5	1	2
18 In.	7		
24 In.	8	2	3

Add to your BOM:

Part Number	Description	Qty per Tee	Std Pkg Qty
PWBIB^**	Radius Intersection Bracket, Set of 2	2 Brackets	1 pkg
PWBHK**-L	Hardware Kit, 50 pcs	8 Pieces	50 pcs
PWBSPL**-L	Bolt-On Splice, 50 pcs	See Table	50 pcs



PWBHK**-L
Hardware Kit
Qty = 4

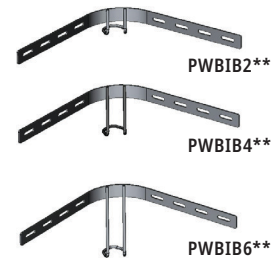

Best Option: Formed Tees

Ex. PWBPF4X18BL

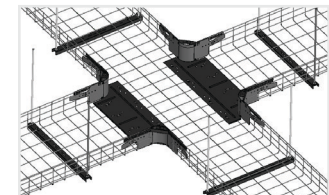
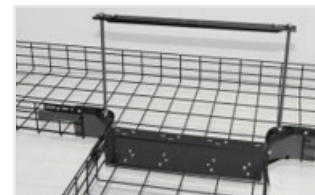
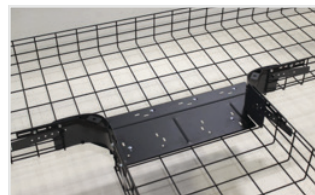
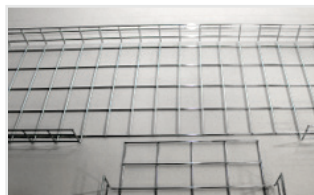

With the option, there are opportunities to mount a secondary pathway over the tee

To make a four-way cross, two sets of the tees or radius intersections

1. The horizontal section of the pathways must have two open spaces on both sides of the sidewall.
2. The vertical pathway must also have two quadrants of the pathway removed.
3. Radius intersection should be placed at the corners. Tighten with the hardware provided.
4. The top plate should be placed to cover the gaps of the pathway.
5. The protective sheets should go along the corner radius and tighten with fasteners and cable ties.

Note: Replace ** with BL for Black, EZ for Electro Zinc, or WH for White
Replace ^ with 2, 4, or 6 sidewall height

Vertical Level Changes

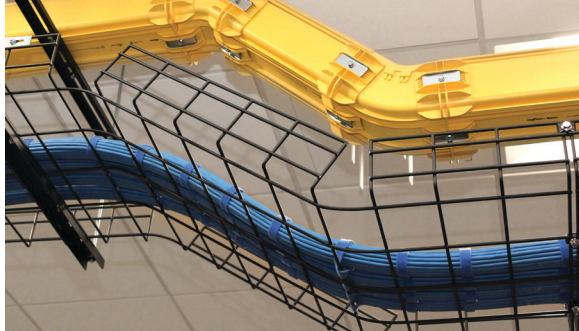

Vertical level changes are easily formed by cutting away sidewall sections on each side of the basket and bending the pathway to the desired angle.

- 2 Inch sidewall can be bent 90° with a 2.5 inch radius
- 4 Inch sidewall can be bent 90° with a 7.5 inch radius
- 6 Inch sidewall can be bent 90° with a 13 inch radius

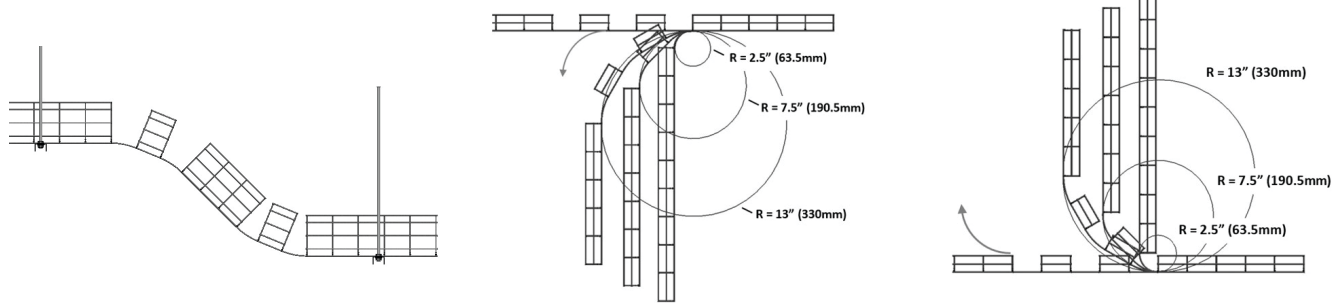

Horizontal Sweeping Bends

Wire Basket can be field fabricated to create custom horizontal bend angles by cutting away and removing bottom and sidewall wires in one or more crosswire sections before bending the pathway to the required angle.

The smaller inside radius is secured using PWBSPL**-L Bolt on Splices, PWBSPL2**-L 2-Hole Sweeping Bend Splice Plates, or a field fabricated 3-Hole Splice Plate cut from longer PWBSPL5**-L 5-Hole Sweeping Splice Bars. The larger outside radius of all fabricated sweeping bends are reinforced using 5-Hole Sweeping Splice Bars or PWBFE5**-30 Flat Expansion Splice Bars. Two PWBHK**-L Hardware Kit pieces are used to secure each flat splice component to the vertical cross wires on each side of the wire basket profile.

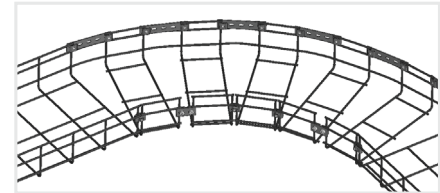

PWBSPL5**-L 5-Hole Sweeping Bend Splice Bar or PWBFE5**-30 Flat Expansion Bar with PWBHK**-L Hardware Kits



PWBSPL**-L Bolt on Splice



PWBSPL2**-L 2-Hole Sweeping Bend Splice Plate with PWBHK**-L Hardware Kits

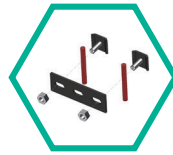

3-Hole Sweeping Bend Splice Bar Fabricated From PWBSPL5**-L with PWBHK**-L Hardware Kits

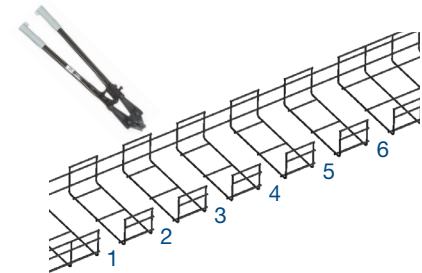
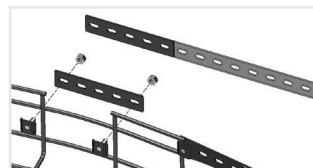
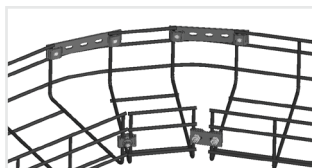

Example: 90° horizontal sweep requires 6 crosswire sections to be removed from a PWB4X12**-L basket

Note: Replace ** with BL for Black, EZ for Electro Zinc, or WH for White

This table can be used to estimate the amount of hardware needed to fabricate various sized horizontal sweeping bends from each of the six pathway widths. Refer to the product instruction sheet for detailed instruction on how to fabricate horizontal sweeping bends.

Basket Part Number	Inside Radius In.	Bend Angle																												
		Basket Sections to Cut Away				PWBSPL** -L Bolt-On Splices				2-Hole PWBSPL5** or Cut PWFES**-30 Splice Bar				3-Hole Splice Bar Cut From PWSPL5** or PWFES**-30				5-Hole PWBSPL5** or Cut PWFES**-30 Splice Bar				PWBHWK** -L Hardware Kit Pieces								
		30°	45°	60°	90°	30°	45°	60°	90°	30°	45°	60°	90°	30°	45°	60°	90°	30°	45°	60°	90°	30°	45°	60°	90°					
PWB2X4**	6		1		2					1	0	1	0					1		2			1		2	4		6		
PWB4X4**													1													4		8		
PWB2X6**	9.25	1		2			0			2	1	2	2					0		0			1		2	4		8		
PWB4X6**					3	0		0																3		6	12	12	10	
PWB6X6**			2							4	2	4	4										2							
PWB2X8**	12.5																						2							
PWB4X8**					4		1			2		1	0					2		4						4		8	12	
PWB6X8**			2		4							2		4		4		4		8			2		4	12		24		
PWB2X12**	18.25						2			4													2		4					
PWB4X12**			3		6	1		2		1	1	2	2											3	6	6	8	12	16	
PWB6X12**						2	4	4	8	2	2		4								0					8	10	16	20	
PWB2X18**	22.5												4							0										
PWB4X18**			3	4	6	8	0	0		2	8	4	4										3	4	6	8	16	16	20	16
PWB6X18**												16	8	8	8													24	24	28
PWB2X24**	31							4																						
PWB4X24**			4	6	8	11	2	6		11	2		4		0	0	0						4	6	8	11	12	12	24	22
PWB6X24**								12	8	22	4		0	8																
PWB2X30**	39.5																													
PWB4X30**			5	7	10	14	4	7	8	14	1		2										5	7	10	14	16	21	32	42
PWB6X36**								8	14	16	28	2		4														22	28	44
PWB2X36**	47.3																													
PWB4X36**			6	9	11	17	5	7	11	16	1	2		1							0		6	9	11	17	19	29	33	54
PWB6X36**								10	14	22	32	2	4		2													26	40	44

**NOTE: Bolded Cells need two 10ft pathway sections



PWB4X4 30° Angle:**

- 3-Hole Sweeping Bend Splice Bar x 1 Pc
- PWBSPL5** 5-Hole Sweeping Bend Splice Bar x 1 Pc
- PWBHK** -L Hardware Kit x 4 Pc

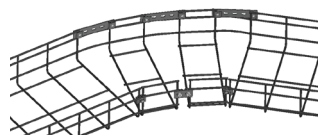

PWB12X4 45° Angle:**

- PWBSPL** -L Bolt-On Splice x 2
- PWBSPL2 2-Hole Sweeping Bend Splice Bar x 1 Pc
- PWBSPL5** 5-Hole Sweeping Bend Splice Bar x 3 Pc
- PWBHK** -L Hardware Kit x 8 Pc



PWB18X4 60° Angle:**

- PWBSPL** -L Bolt-On Splice x 2
- PWBSPL2 2-Hole Sweeping Bend Splice Bar x 4 Pc
- PWBSPL5** 5-Hole Sweeping Bend Splice Bar x 6 Pc
- PWBHK** -L Hardware Kit x 20 Pc

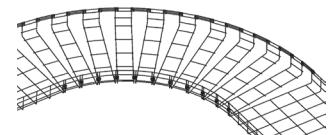

PWB24X4 90° Angle:**

- PWBSPL** -L Bolt-On Splice x 11
- PWBSPL5** 5-Hole Sweeping Bend Splice Bar x 11 Pc
- PWBHK** -L Hardware Kit x 22 Pc

Note: Replace ** with BL for Black, EZ for Electro Zinc, or WH for White

Mounting Details

Flexible mount bracket options allow the Panduit Wire Basket System to be installed in almost any configuration. Flat mounting surfaces simplify installation and allow pathway sections to safely slide over brackets as they are moved into position and baskets are secured to the brackets using two PWBHK**-L Hardware Kit pieces per bracket.

Mount brackets should be placed within two-feet (610mm) of pathway intersections and spaced between four and eight feet apart over extended lengths where multiple basket sections are spliced together. Refer to Safe Working Load Table for more information on the amount of weight basket sections can safely carry and different support span distances.

Part Number	Safe Working Load (lb/ft) Support Span Distance				
	4 Ft. Span	5 Ft. Span	6 Ft. Span	7 Ft. Span	8 Ft. Span
PWB2X4**	27	22	18	17	15
PWB2X6**	45	40	32	24	21
PWB2X8**	64	52	33	25	
PWB2X12**	54	49	45	32	23
PWB2X18**	96	75	55	42	29
PWB2X24**	99	73	48	37	27
PWB2X30**	69	55	50	75	46
PWB2X36**	65	50	40	40	40
PWB4X4**	36	34	31	29	21
PWB4X6**	45	41	38	30	24
PWB4X8**	71	59	46	43	40
PWB4X12**	102	84	75	57	46
PWB4X18**	97	85	72	58	
PWB4X24**	128	101	74	59	42
PWB4X30**	83	70	67	61	55
PWB4X36**	78	65	76	76	
PWB6X6**	85	75	67	49	33
PWB6X8**	101	91	79	63	47
PWB6X12**	114	103	85	65	55
PWB6X18**	110	97		67	51
PWB6X24**	134	110	69	56	56
PWB6X30**	95	75	62	53	44
PWB6X36**	89	65	47	41	35

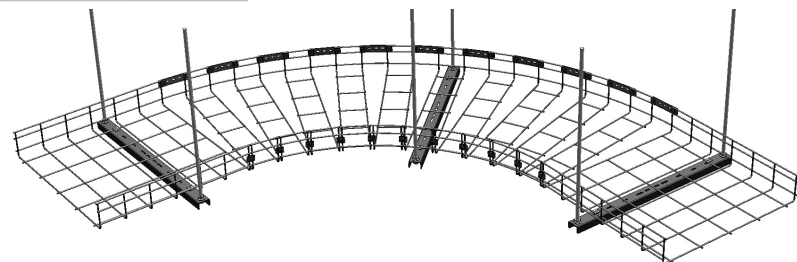
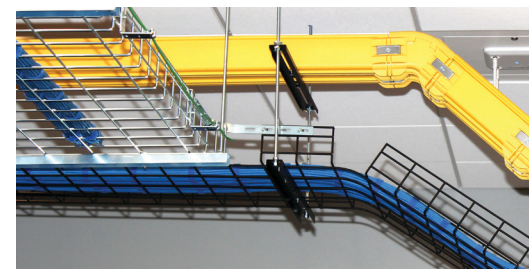
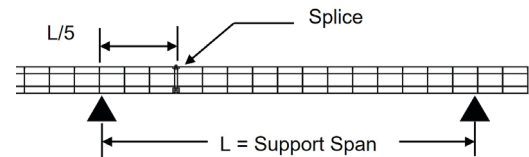
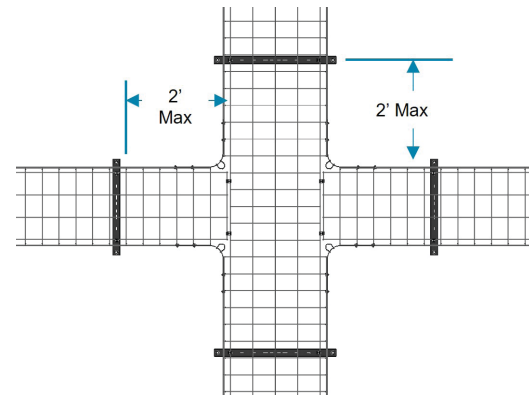

Place supports near the top and bottom of field fabricated vertical transitions and near the center of large horizontal sweeping bends.

Note: Replace ** with BL for Black, EZ for Electro Zinc, or WH for White

Trapeze Bracket with Center Hole

Part Number	For Pathway Size	Length In. (mm)	Width In. (mm)	Height (Thickness) In. (mm)	PWBHK**-L Hardware Pieces Required	Std. Pkg. Qty.
PWBTB4C**	4" Wide Pathway	8.5 (216)	1.82 (46)	1.13 (29)	2	1
PWBTB6C**	6" Wide & Under	10.5 (266)				
PWBTB8C**	8" Wide & Under	12.5 (318)				
PWBTB12C**	12" Wide & Under	16.5 (419)				
PWBTB18C**	18" Wide & Under	22.5 (571)				
PWBTB24C**	24" Wide & Under	28.5 (724)				
PWBTB30C**^	30" Wide & Under	34.5 (876)				
PWBTB36C**^	36" Wide & Under	40.5 (1,029)				

^Center hole not available for 30" and 36" wide pathways



Cantilever Brackets

Part Number	For Pathway Size	Length In. (mm)	Width In. (mm)	Height (Thickness) In. (mm)	PWBHK**-L Hardware Pieces Required	Std. Pkg. Qty.
PWBCB4**	4" Wide Pathway	5.0 (128)	1.97 (50)	3.54 (90)	2	1
PWBCB6**	6" Wide & Under	7.0 (178)	1.97 (50)	3.93 (100)		
PWBCLB8**	8" Wide & Under	8.74 (222)	1.57 (40)	3.57 (91)		
PWBCLB12**	12" Wide & Under	12.8 (326)	1.57 (40)	4.33 (110)		
PWBCLB18**	18" Wide & Under	18.7 (476)	1.57 (40)	5.51 (140)		
PWBCLB24**	24" Wide & Under	24.6 (626)	1.57 (40)	6.30 (160)		



Stacking Trapeze Brackets

Part Number	For Pathway Size	Length In. (mm)	Width In. (mm)	Height (Thickness) In. (mm)	Hardware Pieces Required	Std. Pkg. Qty.
PWB12FRTBBL	12" Wide Pathway	16.5 (419)	1.97 (50)	1.77 (45)	Included	1
PWB18FRTBBL	18" Wide & Under	22.5 (571)				
PWB24FRTBBL	24" Wide & Under	28.5 (723)	1.57 (40)			
PWB30FRTBBL	30" Wide & Under	34.5 (876)				



Wall Mount Termination Brackets

Part Number	For Pathway Size	Length In. (mm)	Width In. (mm)	Height (Thickness) In. (mm)	PWBHK-L Hardware Pieces Required	Std. Pkg. Qty.
PWBWMW**	6", 8", 18" and 24"	6.2 (157.72)	2.12 (53.85)	3.12 (79.25)	4	2
PWBWMN**	4" and 12"	4.71 (119.62)	2.12 (53.85)	3.12 (79.25)		

Note: Replace ** with BL for Black, EZ for Electro Zinc, PG for Pre-Galvanized, or WH for White



Trapeze Hanger Brackets

Part Number	For Pathway Size	Threaded Rod Pitch In.	Std. Pkg. Qty.
PWBTSBEZ-L	12" Wide & Under	1/2"	50



Strut Mount Clips

Part Number	For Pathway Size	Length In. (mm)	Width In. (mm)	Height (Thickness) In. (mm)	Std. Pkg. Qty.
PWBSCEZ	All	TBD By Contractor	1.625 (41) Wide Strut	Any Strut Height	50

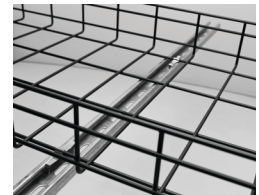

Underfloor Support Bracket

Part Number	For Pathway Size	Length In. (mm)	Width In. (mm)	Height (Thickness) In. (mm)	Hardware Pieces Required	Std. Pkg. Qty.
PWBUSB	Up to 20" Wide	29.15 (740)	5.47 (139)	2.13 (54)	Included	1

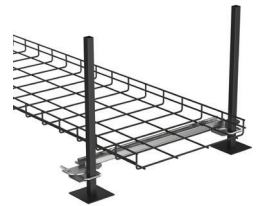

Sidewall Mount and Accessory Bracket

Part Number	For Pathway Size	Length In. (mm)	Width In. (mm)	Height (Thickness) In. (mm)	Hardware Pieces Required	Std. Pkg. Qty.
PWBSWMBPG	4" Wide Pathway	3.46 (88)	2.64 (67)	1.76 (48)	-	1



Pre-Formed Tees

Part Number	For Pathway Size	Length In. (mm)	Width In. (mm)	Height (Thickness) In. (mm)	Hardware Pieces Required	Std. Pkg. Qty.
PWBPF2X^**	2X4; 2X6; 2X8; 2X12; 2X18; 2x24	29.15 (740)	5.47 (139)	2.13 (54)	Included	1
PWBPF4X^**	4X4; 4X6; 4X8; 4X12; 4X18; 4X24					
PWBPF6X^**	6X6; 6X8; 6X12; 6X18; 6X24					

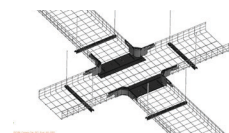

Radius Intersection Bends

Part Number	For Pathway Size In. (mm)	Length In. (mm)	Width In. (mm)	Height (Thickness) In. (mm)	PWBHK**-L Hardware Pieces Required (Right Angle)	PWBHK**-L Hardware Pieces Required (Tee Intersection)	Std. Pkg. Qty.
PWBIB2**	2 (50) Wall Height	11.61 (295)	11.18 (284)	2.12 (54)	4	8	2
PWBIB4**	4 (100) Wall Height			4.12 (105)			
PWBIB6**	6 (150) Wall Height			6.12 (156)			

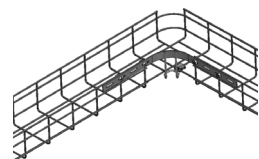

Note: Replace ^ with pathway width
 Replace ** with BL for Black, WH for White, or EZ for Electro-Zinc

Cable Exit Accessories

Bottom Waterfalls

- PWBFW5R2** Tool-less Wide Waterfall
- PWBWFNR2** Tool-less Narrow Waterfall

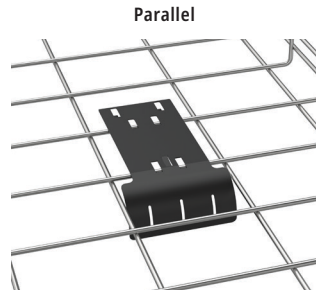

Parallel

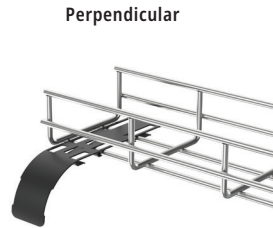

Perpendicular

12" Drop Out Kit



PWBDOK**
(includes all necessary hardware)

Spillover

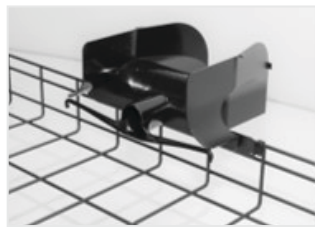

PWBSPJ2BL
PWBSPJ4BL

Application:

Basket Width	Installation Direction	PWBWF5R2**	PWBWFNR2**
4 In.	Parallel	–	✓
	Perpendicular	–	✓
6 In.	Parallel	–	✓
	Perpendicular	–	✓
8 In.	Parallel	✓	✓
	Perpendicular	✓	–
12 In.	Parallel	✓	✓
	Perpendicular	✓	–
18 In.	Parallel	✓	✓
	Perpendicular	✓	–
24 In.	Parallel	✓	✓
	Perpendicular	✓	–
30 In.	Parallel	✓	–
	Perpendicular	✓	–
36 In.	Parallel	✓	✓
	Perpendicular	✓	–

Special Note

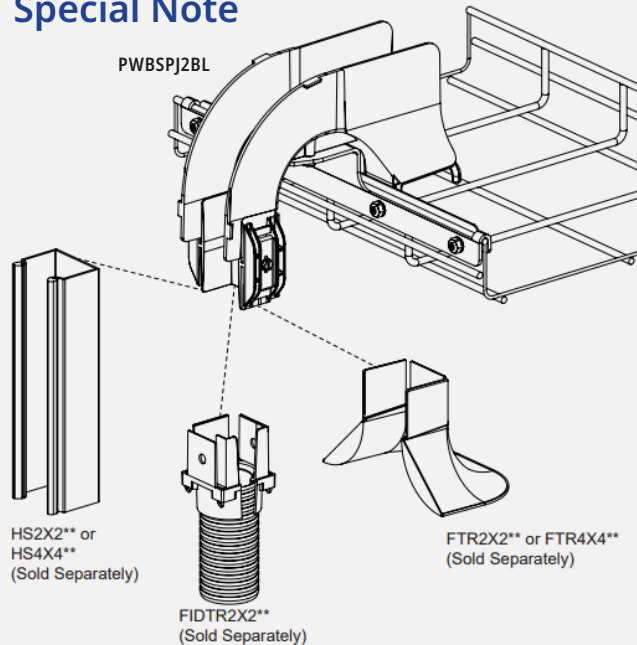

Optional accessories can be installed to the bottom back exit geometry of spillover fittings using FiberRunner FBC2X2LBL or FRBC4X4LBL barbed coupler fittings

Note: Replace ** with BL for Black, EZ for Electro Zinc, or WH for White

Accessories

Cable Slack Manager – PWBCSMBL

Mounts to any Wire Basket sidewall height...

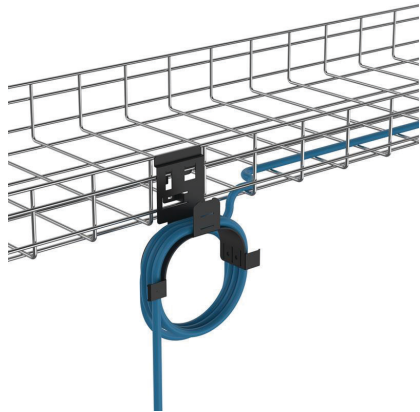

inside any Wire Basket pathway width...

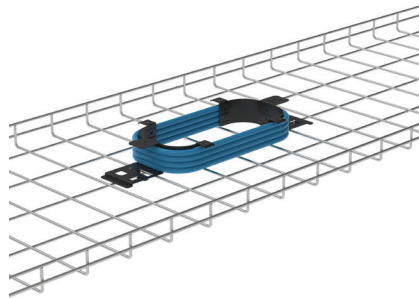

and underneath any pathway width to neatly manage excess cable slack.

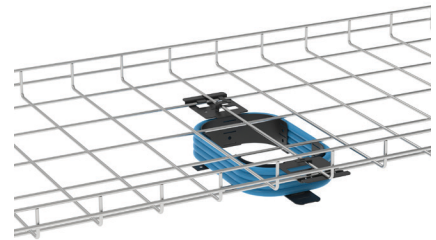

Sidewall and Accessory Mount – PWBSWMBPG

Sidewall Accessory Mounting

Compatible with all heights; 2", 4", and 6"

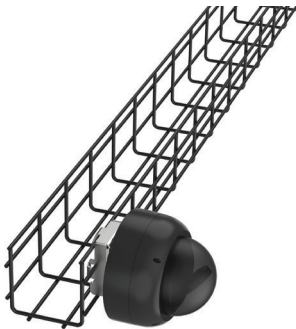

Wall Mounting

Compatible with 4" wide pathways only

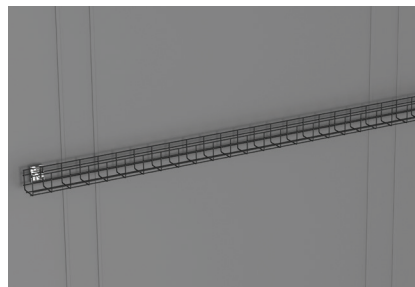

Under Basket Accessory Mounting

Compatible with 4" wide pathways only



Visit our online catalog at panduit.com



Tray Liners and Divider Walls

Metal Tray Liners

Metal tray liners come in two, 63 inch lengths. The tray liner overlaps to cover the 10 foot pathway. The clip provides electrical continuity.

Ex. PWBTL4BL

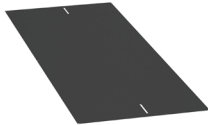

Part Number	For Use with Pathway Width
PWBTL4**	4 In.
PWBTL6**	6 In.
PWBTL8**	8 In.
PWBTL12**	12 In.
PWBTL18**	18 In.
PWBTL24**	24 In.

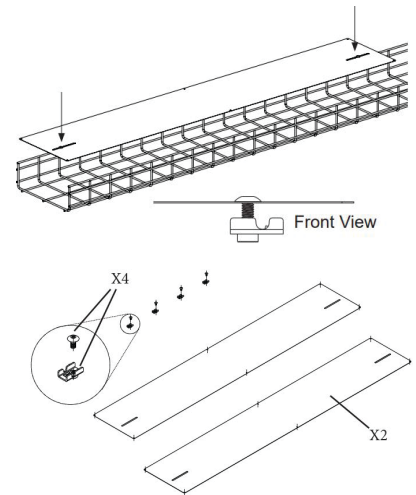

Plastic Tray Liners

Plastic tray liners come in one 100 ft. roll. The roll is perforated to accommodate sidewall and bottom-only applications.

Ex. PWBPTL4X18BL

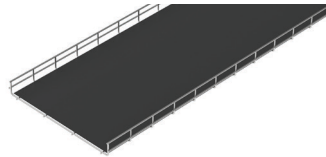
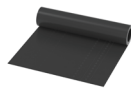

Bottom Only

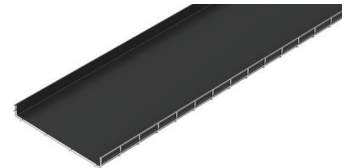

Sidewall

For a full list of Plastic Tray Liner part numbers, [see our online catalog](#)

Divider Wall

Divider Wall comes in two, 63 inch lengths that will be overlapped and will be tightened with the included hardware components.

Part Number	Pathway Wall Height
PWBWD2**	2 In.
PWBWD4**	4 In.
PWBWD6**	6 In.

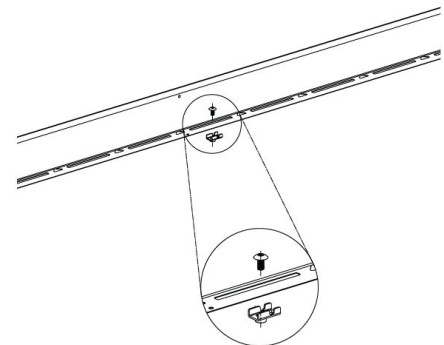
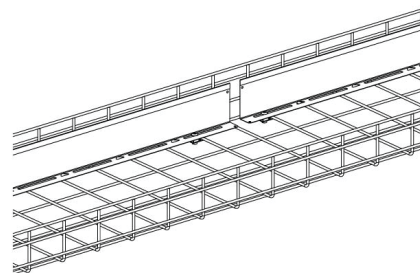

To accommodate sweeps, the divider walls can be trimmed as shown below:

For Sweeping Radius

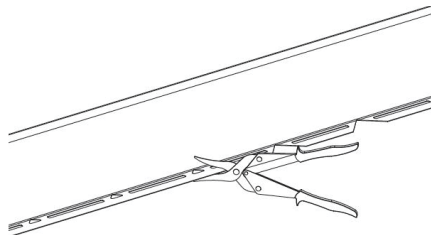

Articulated for Sweeping Radius

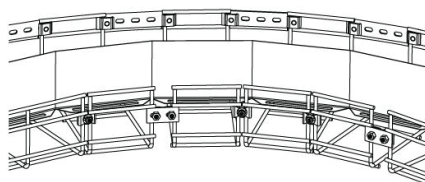

Note: Replace ** with BL for black, WH for white, PG for pre-galvanized.

Metal Covers and Cover Retention Straps

Metal Tray Covers

Each cover is comprised of 3 individual sections that will cover one 10-foot length of basket.

Part Number	For Use with Pathway Width
PWBCVR4**	4 In.
PWBCVR6**	6 In.
PWBCVR8**	8 In.
PWBCVR12**	12 In.
PWBCVR18**	18 In.
PWBCVR24**	24 In.
PWBCVR30**	30 In.
PWBCVR36**	36 In.

Note: Replace ** with BL for Black or EZ for Electro Zinc

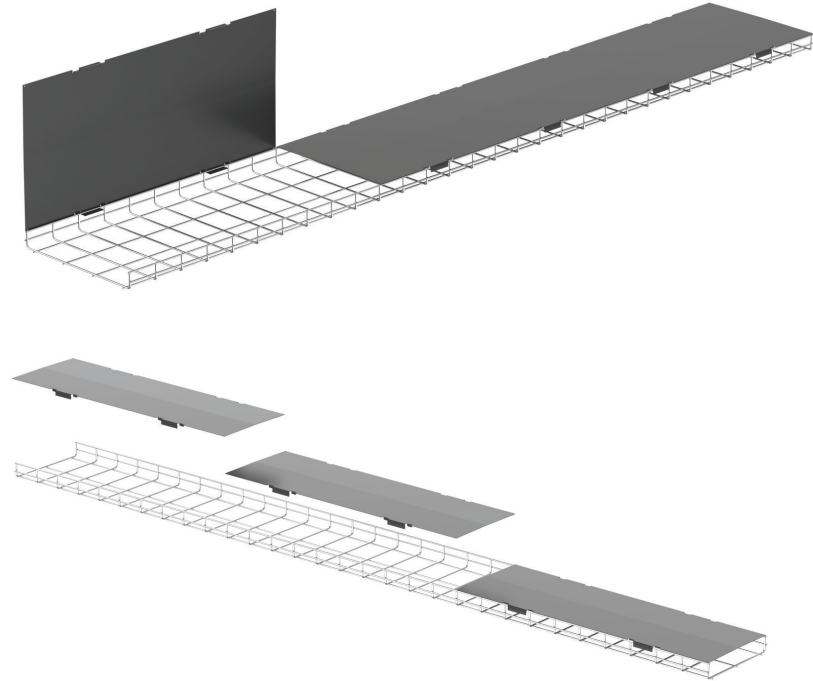

Tamper-Resistant Cover Retention Straps

Our Tamper-Resistant Cover Retention Strap includes a specialty screw and bit hardware. It comes in pre-galvanized finish. Recommended 6 straps per one 10-foot length of covered basket.

Part Number	Pathway Wall Height
PWBCVRLCK2X4	2 x 4 In.
PWBCVRLCK2X8	2 x 8 In.
PWBCVRLCK2X18	2 x 18 In.
PWBCVRLCK4X12	4 x 12 In.
PWBCVRLCK4X18	4 x 18 In.
PWBCVRLCK4X24	4 x 24 In.
PWBCVRLCK6X18	6 x 18 In.
PWBCVRLCK6X24	6 x 24 In.

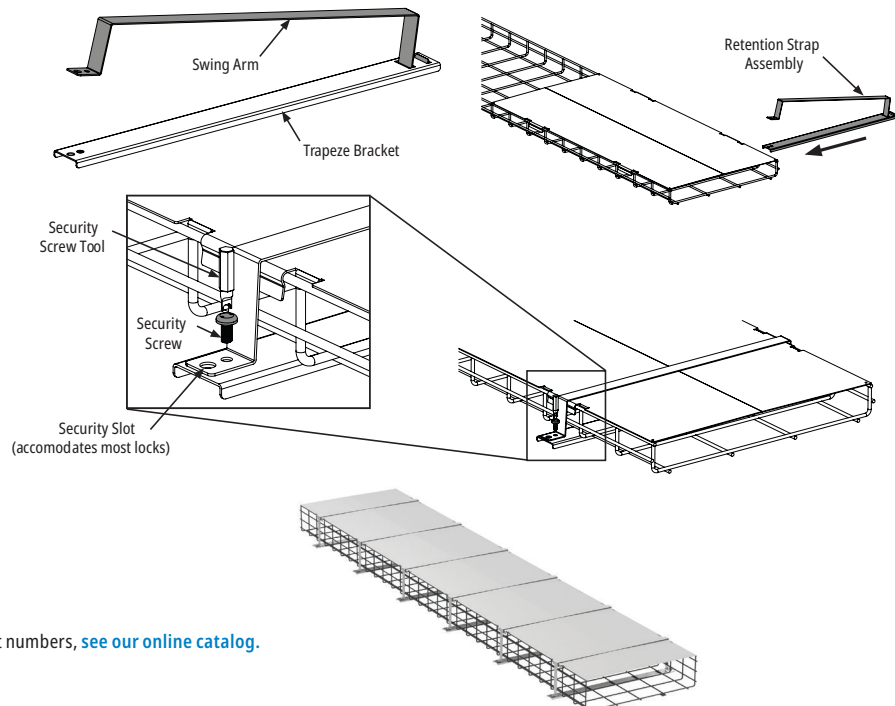

For a full list of Tamper-Resistant Cover Retention Strap part numbers, [see our online catalog](#).

Color and Finish Specifications

Black Powder Coat (BL)

- Complies with ASTM 510
- Nominal spectrophotometer values

L	a	b
26	0.30	-0.76

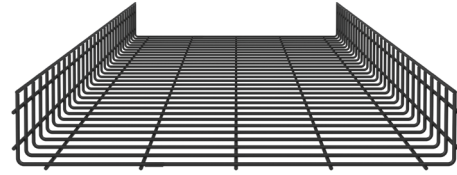

White Powder Coat (WH)

- Complies with ASTM 510
- Nominal spectrophotometer values

L	a	b
92.79	-0.60	0.74

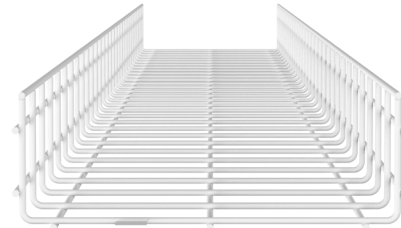

Electro Zinc Coating (EZ)

- Colorless finish that provides a smooth uniform appearance
- Complies with ASTM A633-07

L	a	b
92.79	-0.60	0.74

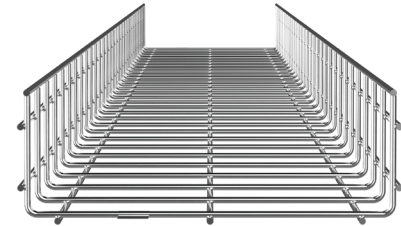

Recommended Applications

Customers can specify a black or white powdered coat for data center applications where they want the cable pathway to match the color of the cabinets. Data centers and telco rooms commonly use electro zinc finishes throughout the enterprise based upon customer preference.

Application Type	BL	WH	EZ
DATA CENTER CONSTRUCTION			
Ambient lighting environment	1	2	2
Low lighting environment	–	1	2
Enterprise and office space	–	2	1
INDUSTRIAL APPLICATIONS			
Factory and automation	–	–	1
General manufacturing	–	–	1
Tray Liner and Divider Walls	1	2	–

1 Primary recommendation

2 Secondary recommendation

Grounding and Bonding

Bonding the Pathway

UL Classified bond, PWSPLBL-L and PWBSPLEZ-L

Using Colored Pathway one must ensure electrical continuity between pathways by properly grounding:



PWBSPLBL-L and PWBSPLEZ-L Bolt on Splices provide a UL Classified bond when installed on areas where the paint has been removed. Powder coated baskets include a masking tape feature that can be removed to expose bare metal on each end. If the the basket is cut, the user should remove the paint from the metal, if it is not an electro zinc version.

Splicing

PWBPSBL-L and PWBPSEZ-L - Bonding jumpers for electrical continuity

Option 1: Using these splices requires a bonding jumper with a mechanical copper lug (optional Panduit part number SBC3-C)



Option 2: Bonding Panduit Wire Basket Overhead Cable Tray Routing can also use the GACB-2 or GACB-3



Radius Intersection

Radius intersections must be electrically bonded. As best practice, if users are not adding a PWBSPLEZ-L, users should use a SBC3-C Split Bolt.



Note: Replace ** with BL for Black, EZ for Electro Zinc, or WH for White

Grounding and Bonding

Complete System

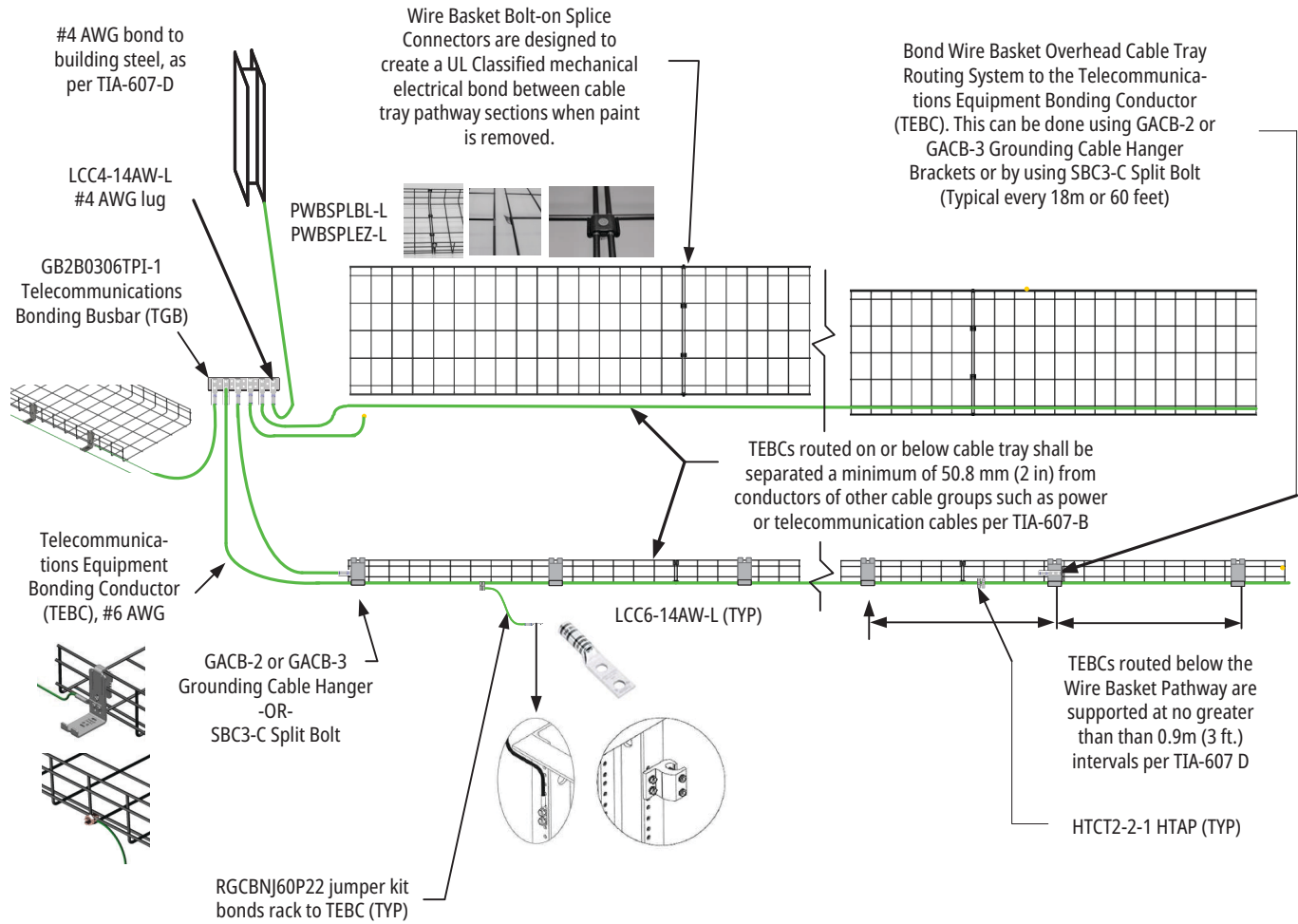

Safety

Personal Protective Equipment

It is important to consider the personal protective gear when installing Wire Basket Overhead Cable Tray Routing System. It is important to always have protective eye gear and work gloves to avoid any injuries. At the various sites it important to consider the use of other protective gear such as helmets and appropriate footwear to add those necessary layers of protection.

Standards

The Wire Basket Overhead Cable Tray Routing System has the following approvals:

- UL listed for their suitability use as Equipment grounding conductor in accordance with sections 392.6(A) and 392.6(B) of the NFPA 70 National Electric Code with AMD 1-5 and NEMA VE1
- Colored Powdered Coated basket complies with ASTM 510
- Electro Zinc basket complies with ASTM B633 SC3, Type III

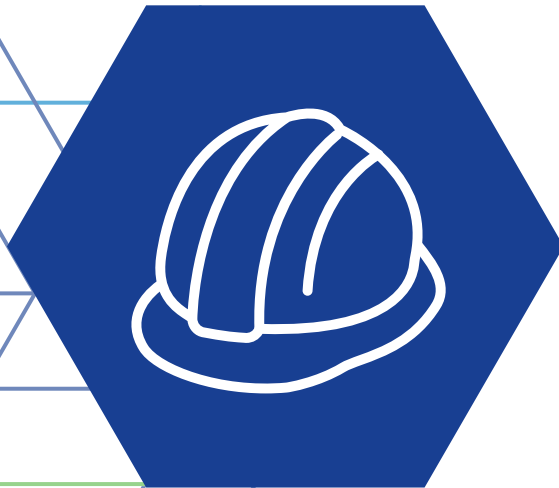

Best Practices

Selecting the Optimal Basket Size

Consider how cabling needs may change—the recommendations for TIA-569-C for 25% initial minimum fill and 50% maximum fill ratios.

Bundling Cable Inside the Basket

Bundling is the preferred way to protect cables and improve organization and aesthetics while separating cables and reducing the risk of damage.

We provide diverse options and colors for hook and loop to easily streamline this task.

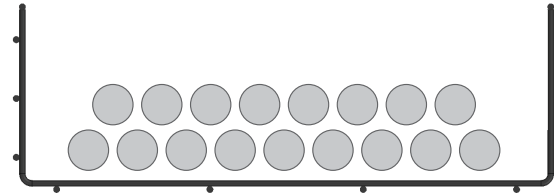
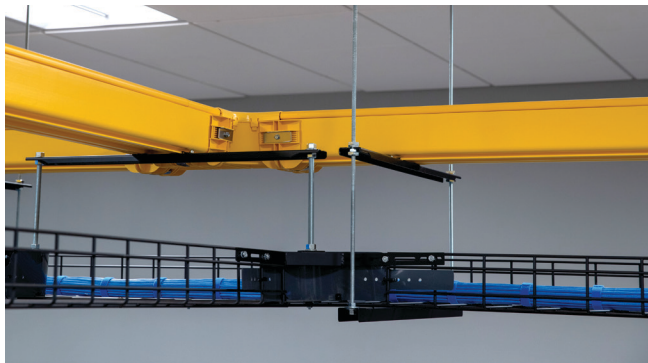

25% calculated fill is recommended when specifying basket size to leave room for future capacity needs.

Sharp Edges and Burrs

The inside of the cable support system shall be free of burrs, sharp edges or projections that can damage cable insulation. Abrasive supports (e.g., threaded rod) installed within the cable fill area shall have that portion within the tray protected with a smooth, non-scratching covering so that cable can be pulled without physical damage.[†]

Best practices dictate that the installer deburr the edges to ensure no sharp edges are present. For corrosive environments, painting the edges is recommended.

Adding Smaller Diameter Fiber Cable

Best practices when installing small diameter fiber cable is to place it in an enclosed pathway such as a FiberRunner system. Nevertheless, if fiber cable is being placed in a wire basket it is important to add a liner to protect cables from attenuation.

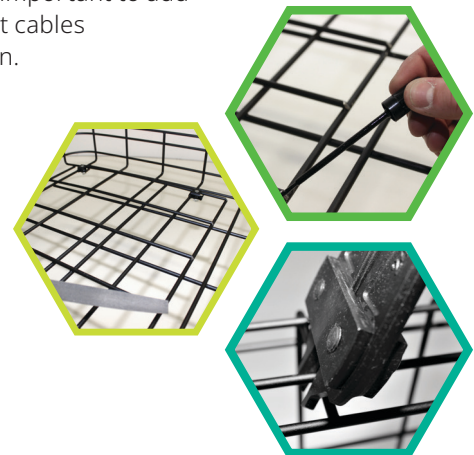

[†]TIA Standards Telecommunications Pathways and Space

Commitment to Sustainability



Recycled Steel

All manufacturers have a responsibility to design environmentally considerate products. Wire Basket contains recycled steel, and the benefits are as follows:

- ① Reduces the use of nonrenewable resources such as coal and iron and the energy required to produce them
- ② Reduces environmental waste and pollution
- ③ Recycled steel does not lose its strength when reused

Packaging and Waste Elimination

Excessive waste is common at installation sites, typically in paperboard packaging materials. Panduit is committed to mitigating such concerns by multi-packaging materials to reduce waste and save installation time.

The benefits of using less packaging are as follows:

- ① Reduces single-use plastic and landfill consumption
- ② Reduces recycling costs incurred by the customer
- ③ Reduces package removal time during installation

Design Tools for Wire Basket Overhead Cable Tray Routing System

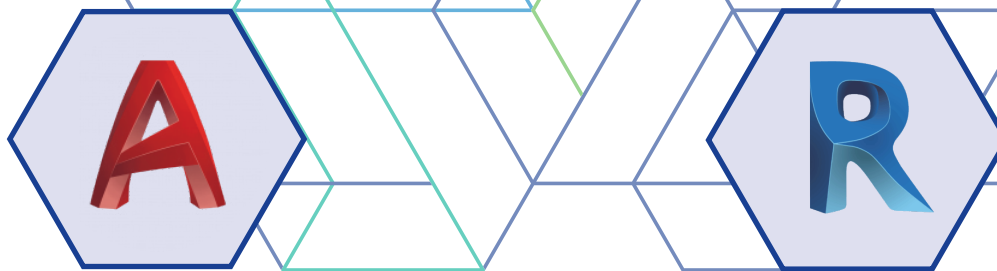

Wire Basket supports various AutoCad blocks which can be accessed with an add-on software package. The .dwg and .dwt versions are available online.

Revit is available for the Wire Basket.

[Click here](#) to access the shapes.

The link provided will direct users to a "BIMOBJECT." Users will register at the website to get access to the many models that are available for the Wire Basket.

If any other items are needed, please reach out to techsupport@panduit.com or dc-infrastructure-support@panduit.com.

Faster Implementation, Simple Specification

Panduit Cable Routing Systems reduce installation time and reduces the risk that can be found with traditional systems. This is accomplished because there are less wires in the basket, which leads to less sharp wires being exposed that can cause injury and damage cable. Cable Management is key to optimizing system reliability, effective space use, and scalability.

Wire Basket Overhead Cable Tray Routing System provides optimal strength, flexibility, and performance for efficient deployment of overhead cabling systems.



Wire Cutting

Reduced up to 50%



Increased Strength

10% greater load capacity



Commitment to Sustainability

Recycled steel, reduced waste



Modular Flexibility

Differential product with options



Focus on Safety

UL listed, NEMA-V1 compliant

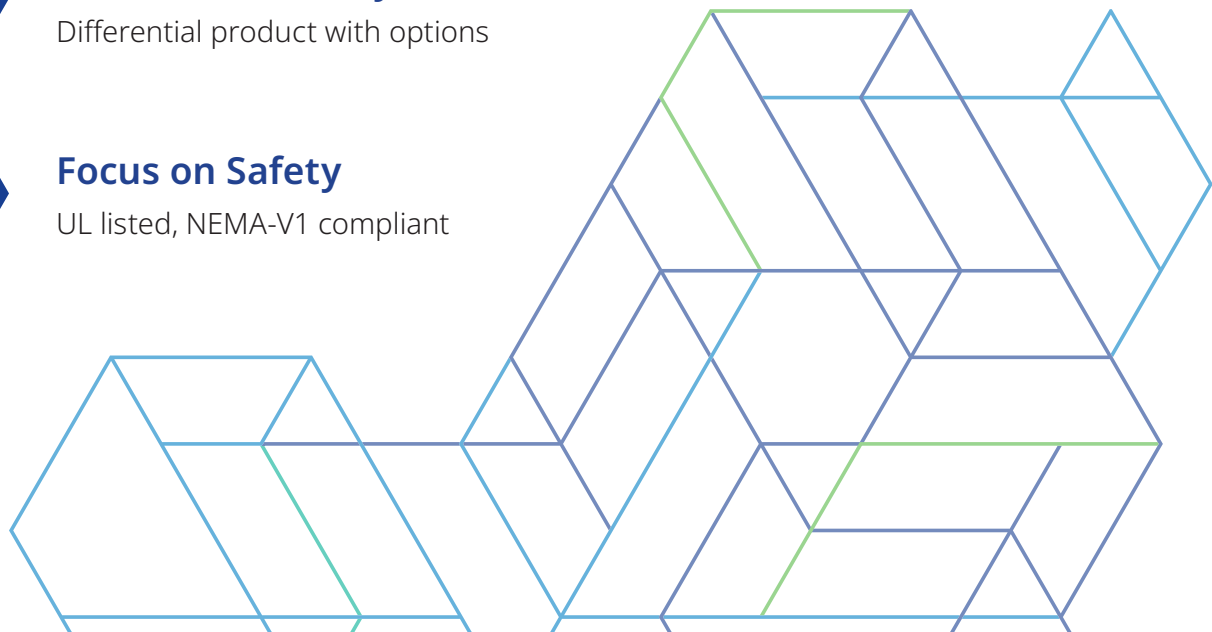

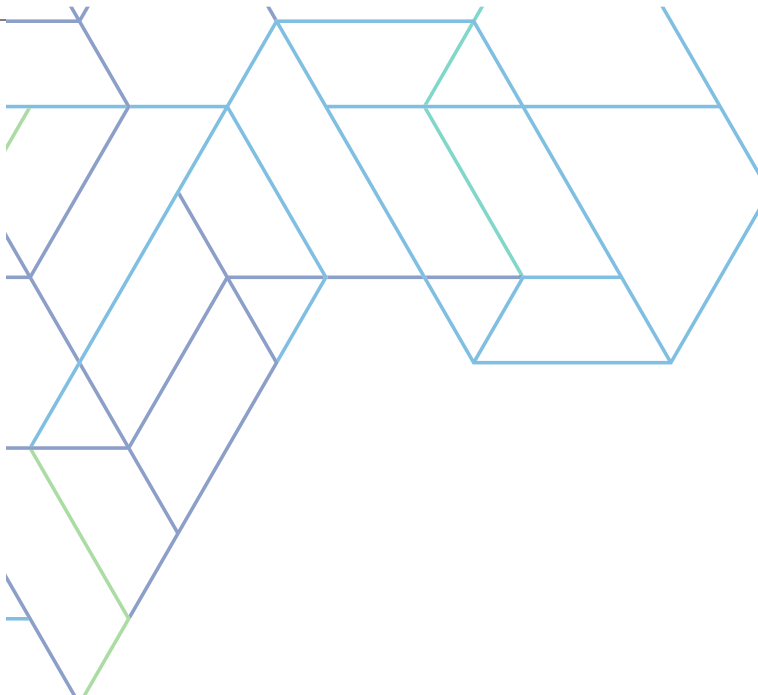

We have the knowledge
and experience to help you
make the most of your
infrastructure investment.

panduit.com



Let's connect
panduit.com/contact-us

PANDUIT™
infrastructure for a connected world

©2026 Panduit Corp. ALL RIGHTS RESERVED. FRAG01-SA-ENG 4/2026