

PANDUIT®

Instructions



Perforation Cutter

DP4300M-PCUT

MADE IN GERMANY

Edition: 09/2024 - **Part No.** DP4300M-PCUT-EN

Copyright

This documentation as well as translation hereof are property of Panduit Corporation. The replication, conversion, duplication or divulgement of the whole manual or parts of it for other intentions than its original intended purpose demand the previous written authorization by Panduit Corporation.

Trademark

Windows is a registered trademark of the Microsoft Corporation.

For more information see www.panduit.com.

Editor

Regarding questions or comments please contact Panduit Corporation.

Topicality

Due to the constant further development of our products discrepancies between documentation and product can occur.

Please check www.panduit.com for the latest update.

Terms and conditions

Deliveries and performances are effected under the General conditions of sale of Panduit Corporation.

Panduit SERVICE CONTACTS

USA & Canada

Phone 1-866-871-4571

[Email GA-Techsupport@panduit.com](mailto:GA-Techsupport@panduit.com)

Latin America

Phone 1-708-532-1800

[Email TechSupportLatAm@panduit.com](mailto:TechSupportLatAm@panduit.com)

Europe/Middle East

Phone +31 -546-580-452

[Email TechSupportEMEA@panduit.com](mailto:TechSupportEMEA@panduit.com)

Asia Pacific

Phone 65-6305-7575

[email TechSupportAP@panduit.com](mailto:TechSupportAP@panduit.com)

Japan

Phone 81-3-6863-6060

TechSupportAP@panduit.com

Australia

Phone 613-9794-9020

TechSupportAP@panduit.com

- 1 Introduction 4**
- 1.1 Instructions 4
- 1.2 Intended Use 5
- 1.3 Safety Instructions 6
- 1.4 Environment..... 6

- 2 Mounting..... 7**

- 3 Operation 9**
- 3.1 Loading Material 9
- 3.2 Standard Operation 10

- 4 Adjusting Cutter Settings with Printer LCD 11**

- 5 Cleaning 12**

- 6 Error Messages 12**

- 7 Approvals 13**

1.1 Instructions

Important information and instructions in this documentation are designated as follows:



Danger!

Draws attention to an exceptionally great, imminent danger to your health or life due to hazardous voltages.



Danger!

Draws attention to a danger with high risk which, if not avoided, may result in death or serious injury.



Warning!

Draws attention to a danger with medium risk which, if not avoided, may result in death or serious injury.



Caution!

Draws attention to a danger with low risk which, if not avoided, may result in minor or moderate injury.



Attention!

Draws attention to possible dangers, material damage or loss of quality.



Note!

Gives you tips. They make a working sequence easier or draw attention to important working processes.



Environment!

Gives you tips on protecting the environment.



Handling instruction



Reference to section, position, illustration number or document.



Option (accessories, peripheral equipment, special fittings).

Time

Information in the display.

1.2 Intended Use

- The device is intended exclusively as an option for the printers of the DP4300M series for cutting and perforating suitable materials that have been approved by the manufacturer. Any other use or use going beyond this shall be regarded as improper use. The manufacturer/supplier shall not be liable for damage resulting from unauthorized use; the user shall bear the risk alone.
- Usage for the intended purpose also includes complying with that manual.
- The device is manufactured in accordance with the current technological status and the recognized safety rules. However, danger to the life and limb of the user or third parties and/or damage to the device and other tangible assets can arise during use.
- The device may only be used for its intended purpose and if it is in perfect working order, and it must be used with regard to safety and dangers as stated in that manual.

**Note!**

All documentations can also currently be found in the Internet.

**Warning!**

This is a class A product. In a domestic environment this product may cause radio interference in which case the user may be required to take adequate measures.

1.3 Safety Instructions

- Disconnect the printer from the electrical outlet before mounting or removing the cutter.
- The cutter may only be operated when it is mounted on the printer.
- Risk of injury, particularly during maintenance, the cutter blades are sharp.
- Work going beyond this may only be performed by trained personnel or service technicians.
- Unauthorized interference with electronic modules or their software can cause malfunctions. Other unauthorized work on or modifications to the device can also endanger operational safety.
- Always have service work done in a qualified workshop, where the personnel have the technical knowledge and tools required to do the necessary work.
- Warning stickers must not be removed, as then you and other people cannot be aware of dangers and may be injured.

1.4 Environment



Obsolete devices contain valuable recyclable materials that should be sent for recycling.

- ▶ Send to suitable collection points, separately from residual waste.

The modular construction of the device enables it to be easily disassembled into its component parts.

- ▶ Send the parts for recycling.
- ▶ Take the electronic circuit boards to public waste disposal centers or to the distributor.

Removing the Tear-off Plate

Before mounting the cutter the tear-off plate mounted on the printer must be removed.

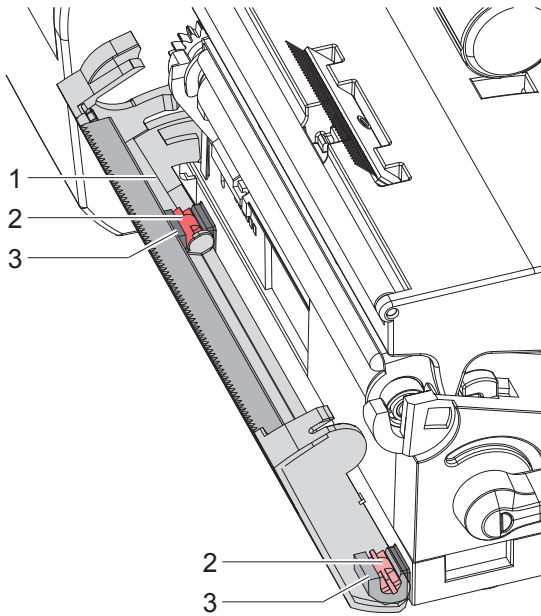

- ▶ Fold down the tear-off plate (1), pull the axles (2) of the tear-off plate out of the holders (3) and remove the tear-off plate.

Mounting the Cutter

**Attention!**

- ▶ Disconnect the printer from the electrical outlet before mounting or removing the cutter.

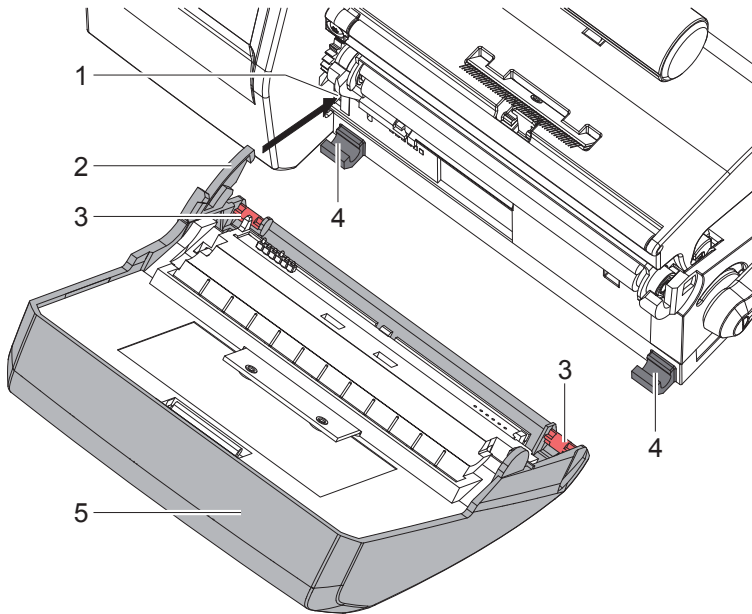

- ▶ Put snap arm (2) of the cutter (5) into the guide (1).
- ▶ Push the axles (3) into the holders (4).
- ▶ Fold up cutter (5) so that it snaps in on the printer.

3.1 Loading Material

- ▶ Fold down the cutter.
- ▶ Insert labels for tear-off mode ▷ Operator's manual of the printer.
Place the media strip between the printhead and the drive roller, so that the front edge of the strip reaches through the cutter.

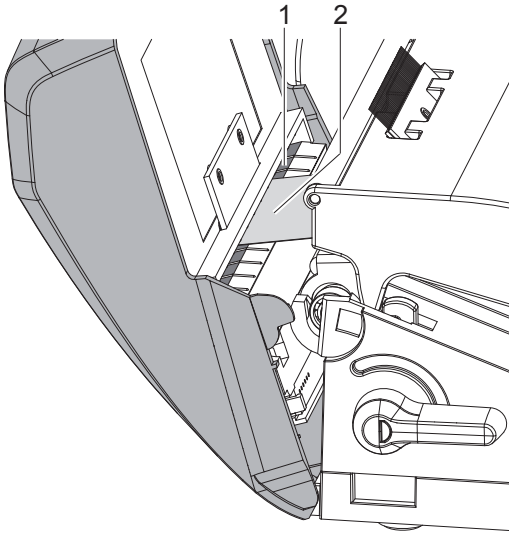

- ▶ Guide the labels (2) into the slot (1) and fold up the cutter.

3.2 Standard Operation

- ▶ Switch on the printer.
The cutter performs a synchronization action.

**Note!**

The cutter will operate with continuous or die cut material. Use Easy Mark Plus labeling software to select the format and use the printer driver to adjust the cutter settings during printing. Or, to adjust the cutter from the printer LCD, using continuous label material, press Setup -> Labels -> Label sensor the setting Continuous media has to be selected. Otherwise no synchronization cut is carried out.

- ▶ Press . For synchronization the media will be moved forward and cut off.
That synchronization is not necessary when the printhead was not opened between print jobs, even if the printer was powered off between print jobs.
- ▶ Adjust cutter options in Easy Mark Plus
 - Select Print Document
 - Select the desired printer and press the properties button
 - On the left hand side, select Accessories Options
 - Select the Perforator option
 - Adjust settings as desired.

**Note!**

Between print jobs a cut can be released by pressing  on the control panel.

**Note!**

Recommended distance between full cuts is 1 inch. Smaller full cuts could cause labels to become jammed. For smaller cuts, use the perforation setting.



**Note!**

Cutter settings are for a specific printer and cutter combination. Changing the cutter may require re-adjustment to the cutter settings.

Cutter control is handled by printing from Easy-Mark Plus labeling software.

Cut Parameters

- ▶ Start menu.
- ▶ Select  Setup >  Cutting.

Parameter	Meaning	Default
 <i>Cut position</i>	Offset of the cut position relative to the rear label edge. The setting can also be adjusted by the software. The settings of configuration and software are added together.	0.0 mm
 <i>Perforation level</i>	Setting of the perforation depth. The setting can also be adjusted by the software. The settings of configuration and software are added together.	0

Label Sensor

- ▶ Start menu.
- ▶ Select  Setup >  Labels.

Parameter	Meaning	Default
 <i>Label sensor</i>	Method for detecting the starting end of the label. <i>Gap Sensor:</i> Detection using changes in the transparency between the label and label gap. <i>Bottom-Reflect:</i> Detection using reflex marks on the bottom of the medium. <i>Continuous media:</i> Checking the existence of media only.	<i>Gap sensor</i>

**Warning!**

- ▶ Disconnect the printer from the electrical outlet.

**Attention!**

Risk of injury. The cutter blades are sharp.

1. Remove the cutter from the printer.
2. Clean cutter with PTR-CLN cleaning kit.
3. Reattach cutter to printer.

6 Error Messages

Error message	Cause	Remedy
<i>Cutter blocked</i>	Cutter cannot return into its home position and stays in an undefined position	<ul style="list-style-type: none"> ▶ Switch off the printer. ▶ Remove material. ▶ Switch on the printer. ▶ Restart print job. ▶ Change material
	No cutter function	<ul style="list-style-type: none"> ▶ Switch the printer off and then on. ▶ If error recurs call service.
<i>Media too thick</i>	The cutter is unable to cut the labels but is able to return into its home position	<ul style="list-style-type: none"> ▶ Press <i>Cancel</i> ▶ Change material.

Reference to the EU Declaration of Conformity and other approvals:

<https://www.panduit.com/DP4300M>



FCC

NOTE : This equipment has been tested and found to comply with the limits for a Class A digital device, pursuant to Part 15 of the FCC Rules. These limits are designed to provide reasonable protection against harmful interference when the equipment is operated in a commercial environment. The equipment generates, uses, and can radiate radio frequency and, if not installed and used in accordance with the instruction manual, may cause harmful interference to radio communications. Operation of this equipment in a residential area is likely to cause harmful interference in which case the user may be required to correct the interference at his own expense.