

Panduit UPS

Installation Manual v2.9

1-20 kVA Uninterruptible Power Supply (VRLA & Lithium),

1-20 kVA External Battery Pack (VRLA & Lithium),

Maintenance Bypass Switches,

Battery Cartridges

Contents

- Section 1 – Overview 5
 - SKU List..... 6
 - UPSs (Uninterruptible Power Supplies) 6
 - EBPs (External Battery Packs)..... 7
 - MBS (Maintenance Bypass Switch) 7
 - Battery Cartridges and Cartridge Sets 7
- Section 2 – Handling (Safety)..... 9
 - Important Safety Warnings 9
 - Overview 9
 - Handling Instructions..... 9
 - Preparation 9
 - Installation 10
 - Operation 11
 - Maintenance, service, and faults..... 11
- Section 3 – UPS, EBP and MBS Mounting 13
 - Racks..... 13
 - Four-Post Racks - Installation 13
 - Install 2U UPS Units (U01N11L, U01N11V, U01S11L, U01S11V, U01N12L, U01N12V, U01S12L, U01S12V, U01N13V, U01S13V, U01N14L, U01S14L, U01N16L-N, U01N18L-N, U02N11L, U02N11V, U02S11L, U02S11V, U02N12L, U02N12V, U02S12L, U02S12V, U02N14L, U02N16L-N, U02N18L-N, U02S14L, U03N11L, U03N11V, U03S11L, U03S11V, U03N12L, U03N12V, U03S12L, U03S12V, U03N14L, U03S14L, U03N15L, U03S15L, U03N16L-N, U03N18L-N, U05N11L, U05S11L, U06N11L, U06S11L, U10N11L, U10S11L, U05N12L, U05S12L, U06N12L, U06S12L, U10N12L, U10S12L) 14**
 - Install 2U EBP Units (UVP024, UVP036, UVP048, UVP072, UVPL12H, UVPL50H) 20**
 - Install 3U UPS Units (U05N11V, U05S11V, U06N11V, U06S11V, U06N12V, U06S12V, U10N11V, U10S11V, U10N12V, U10S12V, U10N32V, U10S32V, U15N32V, U15S32V, U20N32V, U20S32V) 25**
 - Install 3U EBP Unit (UVP240)..... 28**

Install 3U MBS Unit (UMB20K)	36
Install 4U EBP Unit (UVP480)	39
Two-Post Racks	45
Tower Mounting	45
Tower mounting 2U Units (U01N11L, U01N11V, U01S11L, U01S11V, U01N12L, U01N12V, U01S12L, U01S12V, U01N13V, U01S13V, U01N14L, U01S14L, U01N16L-N, U01N18L-N, U02N11L, U02N11V, U02S11L, U02S11V, U02N12L, U02N12V, U02S12L, U02S12V, U02N14L, U02S14L, U02N16L-N, U02N18L-N, U03N11L, U03N11V, U03S11L, U03S11V, U03N12L, U03N12V, U03S12L, U03S12V, U03N14L, U03S14L, U03N15L, U03S15L, U03N16L-N, U03N18L-N, U05N11L, U05S11L, U06N11L, U06S11L, U10N11L, U10S11L, U05N12L, U05S12L, U06N12L, U06S12L, U10N12L, U10S12L, UVP024, UVP036, UVP048, UVP072, UVPL12H, UVPL50H)	46
Tower mounting 3U Units (U05N11V, U05S11V, U06N11V, U06S11V, U06N12V, U06S12V, U10N11V, U10S11V, U10N12V, U10S12V, UVP240)	52
Tower mounting 3-Phase Units (U10N32V, U10S32V, U15N32V, U15S32V, U20N32V, U20S32V, UMB20K)	54
Section 4 – Electrical Connections	55
1-10kVA Single-Phase UPS and Associated EBP (U01N11L, U01N11V, U01S11L, U01S11V, U01N12L, U01N12V, U01S12L, U01S12V, U01N13V, U01S13V, U01N14L, U01S14L, U01N16L-N, U01N18L-N, U02N11L, U02N11V, U02S11L, U02S11V, U02N12L, U02N12V, U02S12L, U02S12V, U02N14L, U02S14L, U02N16L-N, U02N18L-N, U03N11L, U03N11V, U03S11L, U03S11V, U03N12L, U03N12V, U03S12L, U03S12V, U03N14L, U03S14L, U03N15L, U03S15L, U03N16L-N, U03N18L-N, U05N11V, U05S11V, U06N11V, U06S11V, U06N12V, U06S12V, U10N11V, U10S11V, U10N12V, U10S12V, U05N11L, U05S11L, U06N11L, U06S11L, U10N11L, U10S11L, U05N12L, U05S12L, U06N12L, U06S12L, U10N12L, U10S12L, UVP024, UVP036, UVP048, UVP072, UVP240, UVPL12H, UVPL50H)	55
Parallel Mode System Configuration for 5-10kVA Lithium UPS (U05N11L, U05S11L, U05N12L, U05S12L, U06N11L, U06S11L, U06N12L, U06S12L, U10N11L, U10S11L, U10N12L, U10S12L)	65
Parallel Mode Wiring for 5-10kVA Lithium UPS (U05N11L, U05S11L, U05N12L, U05S12L, U06N11L, U06S11L, U06N12L, U06S12L, U10N11L, U10S11L, U10N12L, U10S12L)	67
Single Mode System Configuration with 3-Phase or Single-Phase Output	68
Parallel Mode System Configuration for 3-Phase Units with 3-Phase or Single-Phase Output (U10N32V, U10S32V, U15N32V, U15S32V, U20N32V, U20S32V)	76
Parallel Mode Wiring for 3-Phase UPS units (U10N32V, U10S32V, U15N32V, U15S32V, U20N32V, U20S32V)	78
Optional MBS for 3-Phase UPS.....	79

Optional MBS (UMB20K) Usage for 1-Phase UPS (5-10kVA EU Region Only)	87
Section 5 – Replacing Battery Cartridges.....	92
Internal Battery Cartridges in the 1-3kVA UPS Units (UVC024, UVC036, UVC048, UVC072, ULC024, ULC048, ULC272, ULC372)	92
EBP Battery Cartridge Sets for the 1-3kVA VRLA UPS Systems (UVD024, UVD036, UVD048, UVD072)	94
EBP Battery Cartridge Sets for the 5-10kVA VRLA UPS Systems (UVD240)	97
EBP Battery Cartridge Sets for the 10-20kVA 3-Phase VRLA UPS Systems (UVD480)	99
EBP Battery Cartridge Sets for the 1-3kVA Li EBP (UVPL50H) and 5-10kVA Li EBP (UVPL12H)	101
Appendix A: What’s Included: 1-3kVA NA VRLA UPS (U01N11V, U01S11V, U01N13V, U01S13V, U02N11V, U02S11V, U03N11V, U03S11V,).....	102
Appendix B: What’s Included: 1-3kVA EU VRLA UPS (U01N12V, U01S12V, U02N12V, U02S12V, U03N12V, U03S12V).....	103
Appendix C: What’s Included: 1-3kVA VRLA EBP (UVP024, UVP036, UVP048, UVP072).....	104
Appendix D: What’s Included: 5-10kVA VRLA 1-Phase UPS (U05N11V, U05S11V, U06N11V, U06S11V, U06N12V, U06S12V, U10N11V, U10S11V, U10N12V, U10S12V)	105
Appendix E: What’s Included: 5-10kVA Lithium 1-Phase UPS (U05N11L, U05S11L, U05N12L, U05S12L, U06N11L, U06S11L, U06N12L, U06S12L, U10N11L, U10S11L, U10N12L, U10S12L).....	107
Appendix F: What’s Included: 10-20kVA VRLA 3-Phase UPS (U10N32V, U10S32V, U15N32V, U15S32V, U20N32V, U20S32V)	109
Appendix G: What’s Included: 5-10kVA VRLA EBP (UVP240)	111
Appendix H: What’s Included: 5-10kVA Lithium EBP (UVPL12H).....	112
Appendix I: What’s Included: 10-20kVA 3-Phase VRLA EBP (UVP480).....	113
Appendix J: What’s Included: 3-Phase Maintenance Bypass Switches (UMB20K).....	114
Appendix K: What’s Included: 1-3kVA NA Li UPS (U01N11L, U01S11L, U01N14L, U01S14L, U02N11L, U02S11L, U02N14L, U02S14L, U03N11L, U03S11L, U03N14L, U03S14L, U03N15L, U03S15L).....	115
Appendix L: What’s Included: 1-3kVA EU Li UPS (U01N12L, U01S12L, U02N12L, U02S12L, U03N12L, U03S12L).....	116



Appendix M: What's Included: 1-3kVA NA Li Long Runtime UPS (U01N16L-N, U02N16L-N, U03N16L-N) 117

Appendix N: What's Included: 1-3kVA EU Li Long Runtime UPS (U01N18L-N, U02N18L-N, U03N18L-N) 118

Appendix O: What's Included: 1-3kVA Lithium EBP (UVPL50H) 119

Appendix P: Ground Screw Location, Ground Wire Size, and Recommended Grounding Setup Options. 120

Section 1 – Overview

This Manual provides the instructions for installing the Uninterruptible Power Supply Units, the External Battery Pack (EBP) Units, the Maintenance Bypass Switch (MBS) Units, and the UPS/EBP Battery Cartridges. Refer to the SKU List on page [6](#) for all SKUs included in this Installation Manual.

All units should be installed in an environment within the units' operating parameters.

- Operating Temperature: 0-40°C (no derating)
- Operating Humidity: 0-95% (non-condensing)
- Max. Operating Elevation: 3000 m (10% derating); 1000 m (no derating)
- Protection Class: IP20

All units require mounting support when mounted in a rack. A rail mounting kit and a tower mounting kit are provided with most units. The rail mounting kit is used for the preferred mounting, in a four-post rack. The tower mounting kit is used for mounting on the floor or desk in a vertical orientation.

Refer to the appropriate Appendix in this manual for a detailed list of the components included with the product.

The following three sections provide information on handling, installing, and wiring the SKUs in this manual. There are many common installation steps between the various unit models. Subsections are provided for unique installation steps that must be completed on specific models.

SKU List

These are the SKUs included in this Installation Manual.

UPSs (Uninterruptible Power Supplies)

UPS Model Number	Dimension W*D*H (mm)	Form Factor	Net Weight (kg / lbs.)	UPS Replacement Battery Cartridge	Matched External Battery Pack
U01N11L / U01S11L	440*460*86.5	2U	13.5 / 29.8	ULC024	NA
U01N11V / U01S11V	440*460*86.5	2U	16.6 / 36.6	UVC036	UVP036
U01N12L / U01S12L	440*325*86.5	2U	9.1 / 20.1	ULC024	NA
U01N12V / U01S12V	440*460*86.5	2U	16.2 / 35.7	UVC036	UVP036
U01N13V / U01S13V	440*325*86.5	2U	12.4 / 27.3	UVC024	UVP024
U01N14L / U01S14L	440*325*86.5	2U	10.1 / 22.3	ULC024	NA
U01N16L-N	440*460*86.5	2U	8.6 / 19.0	NA	UVPL50H
U01N18L-N	440*460*86.5	2U	8.1 / 17.9	NA	UVPL50H
U02N11L / U02S11L	440*460*86.5	2U	15.1 / 33.3	ULC048	NA
U02N11V / U02S11V	440*460*86.5	2U	21.5 / 47.4	UVC048	UVP048
U02N12L / U02S12L	440*500*86.5	2U	15.8 / 34.8	ULC272	NA
U02N12V / U02S12V	440*460*86.5	2U	20.5 / 45.2	UVC048	UVP048
U02N14L / U02S14L	440*500*86.5	2U	17 / 37.5	ULC272	NA
U02N16L-N	440*500*86.5	2U	11.2 / 24.7	NA	UVPL50H
U02N18L-N	440*500*86.5	2U	10.1 / 22.3	NA	UVPL50H
U03N11L / U03S11L	440*640*86.5	2U	28.1 / 61.9	ULC372	NA
U03N11V / U03S11V	440*600*86.5	2U	27.6 / 60.8	UVC072	UVP072
U03N12L / U03S12L	440*640*86.5	2U	20.6 / 45.4	ULC372	NA
U03N12V / U03S12V	440*600*86.5	2U	27.9 / 61.5	UVC072	UVP072
U03N14L / U03S14L	440*640*86.5	2U	22.4 / 49.4	ULC372	NA
U03N15L / U03S15L	440*640*86.5	2U	21.8 / 48.1	ULC372	NA
U03N16L-N	440*500*86.5	2U	12.2 / 26.9	NA	UVPL50H
U03N18L-N	440*500*86.5	2U	10.7 / 23.6	NA	UVPL50H
U05N11V / U05S11V	440*666.5*131	3U	19.3 / 42.5 67.5 / 148.5	NA	UVP240
U06N11V / U06S11V	440*666.5*131	3U	17.5 / 38.5 67.5 / 148.5	NA	UVP240
U10N11V / U10S11V	440*666.5*131	3U	20 / 44 67.5 / 148.5	NA	UVP240
U06N12V / U06S12V	440*666.5*131	3U	17.5 / 38.5 67.5 / 148.5	NA	UVP240
U10N12V / U10S12V	440*666.5*131	3U	20 / 44 67.5 / 148.5	NA	UVP240
U10N32V / U10S32V	440*660*131	3U	25 / 55.1 145 / 319	NA	UVP480
U15N32V / U15S32V	440*660*131	3U	27 / 59.5 145 / 319	NA	UVP480
U20N32V / U20S32V	440*660*131	3U	30 / 66.1 145 / 319	NA	UVP480
U05N11L / U05S11L	440*621.5*86.5	2U	16.4 32.6 / 71.9	NA	UVPL12H

UPS Model Number	Dimension W*D*H (mm)	Form Factor	Net Weight (kg / lbs.)	UPS Replacement Battery Cartridge	Matched External Battery Pack
U06N11L / U06S11L	440*621.5*86.5	2U	15.2 32.6 / 71.9	NA	UVPL12H
U10N11L / U10S11L	440*621.5*86.5	2U	16.8 32.6 / 71.9	NA	UVPL12H
U05N12L / U05S12L	440*621.5*86.5	2U	15.1 32.6 / 71.9	NA	UVPL12H
U06N12L / U06S12L	440*621.5*86.5	2U	15.1 32.6 / 71.9	NA	UVPL12H
U10N12L / U10S12L	440*621.5*86.5	2U	16.7 32.6 / 71.9	NA	UVPL12H

EBPs (External Battery Packs)

SKU	Dimension W*D*H (mm)	Form Factor	Net Weight (kg / lbs.)	EBP Replacement Battery Cartridge Set
UVP024	440*430*86.5	2U	17.9 / 39.3	UVD024
UVP036	440*430*86.5	2U	23.1 / 50.8	UVD036
UVP048	440*550*86.5	2U	30 / 66	UVD048
UVP072	440*710*86.5	2U	43 / 94.6	UVD072
UVP240	440*666.5*131	3U	67.5 / 148.5	UVD240
UVP480	443*896.5*175	4U	145 / 319	UVD480
UVPL12H	440*684*86.5	2U	32.6 / 71.9	NA
UVPL50H	440*684*86.5	2U	30 / 66.1	NA

MBS (Maintenance Bypass Switch)

SKU	Dimension W*D*H (mm)	Form Factor	Net Weight (kg / lbs.)
UMB20K	440*660*131	3U	15 / 33.1

Battery Cartridges and Cartridge Sets

SKU	Dimension W*D*H (mm)	Net Weight (kg / lbs.)
ULC024	193*173*78	2.7 / 5.9
ULC048	193*173*78	4.0 / 8.8
ULC272	193*340*78	5.3 / 11.8
ULC372	193*506*78	8.0 / 17.6
UVC024	202*153*74	5.3 / 11.6
UVC036	153*306*74	7.7 / 16.9
UVC048	202*304*74	10.4 / 22.8
UVC072	202*455*74	15.6 / 34.3
UVD024	2x 153*306*74	2x 5.3 / 2x 11.6
UVD036	2x 153*306*74	2x 7.7 / 2x 16.9
UVD048	2x 153*403*74	2x 10.4 / 2x 22.8

SKU	Dimension W*D*H (mm)	Net Weight (kg / lbs.)
UVD072	2x 153*603*74	2x 15.6 / 2x 34.3
UVD240	2x 334*607*114 1x 167*607*114	2x 21.4 / 2x 47.2 1x 10.4 / 1x 22.8
UVD480	4x 107*701*156	4x 30.4 / 4x 67.0

Section 2 – Handling (Safety)

Important Safety Warnings

Important safety instructions – Save these instructions







Overview

Please comply with all warnings and operating instructions. Save this manual for future reference. Carefully read and follow these instructions before installing the unit. Do not operate this unit before reading all the safety information and operating instructions carefully.

Dangerous voltages and high temperatures exist inside the UPS. During the installation, operation, and maintenance of these units, please abide by the local safety rules and related laws. Failure to do so may result in personal injury or equipment damage. Safety instructions in this manual function as a supplement to the local safety rules. No liability is assumed for not following the safety rules.

Handling Instructions

Before moving the UPS, be sure to use the original packaging materials to prevent or reduce the possibility of personal injury or damage to the product.

	< 18kg		18-32kg		32-55kg		> 55kg		
	< 40lb		40-70lb		70-120lb		> 120lb		

This product may expose you to chemicals including Nickel (Metallic), which is known to the State of California to cause cancer and birth defects or other reproductive harm. For more information, go to www.P65Warnings.ca.gov.

Preparation

- Consideration must be taken if the UPS system is moved directly from a cold to warm environment. The UPS system must be free of any moisture before installation. Please allow at least two hours for the UPS system to acclimatize to the environment.
- Do not install the UPS system near water or in humid environments.
- Do not install the UPS system where it would be exposed to direct sunlight or near heat sources.
- Do not block ventilation holes in the UPS housing.
- Do not install UPS units in an environment with excessive dust or particulates.

- It is recommended to mount the UPS and EBP unit near the bottom of the rack due to the physical weight of these units.

Installation

- The UPS system must be installed in an environment with a temperature range from 0°C to 40°C.
- The UPS system must be installed in an environment with a humidity from 20% to 90% RH, non-condensing.
- The UPS system may be installed in an environment with an altitude of 1000 meters (3,281ft.) or lower with no de-rating. Derate the load by 1% for every 100 meters above 1000 meters per IEC 62040-3. This is an example of power derating according to altitude:

Altitude (m)	1000	2000	2500	3000	3500	4000	4500	5000
Load coefficient	100%	90%	85%	80%	75%	70%	65%	60%

- Most UPS system units with battery cartridges are heavy and may require a lift to install in the rack/cabinet.
- Each power input on the UPS unit must be protected by a branch circuit protective device rated for the UPS specified on the product rating label.
- Pluggable UPS systems may be installed and operated by a trained qualified layperson.
- Connect the UPS system only to an earth-grounded outlet that is easily accessible and close to the UPS system.
- Permanently wired UPS systems must be installed and wired by trained qualified electricians only.
- For permanently connected UPS systems, ensure source power is off and locked out before installing permanently wired connections to the UPS disconnect device or UPS system.
- For permanently connected UPS systems, a readily accessible disconnect device should be incorporated externally to the UPS system.
- For permanently connected UPS systems, each power input on the UPS systems must be wired with the appropriate wire gauge for the system being installed. Refer to Section 4 – Electrical Connections in this document.
- For permanently connected UPS systems, check for hazardous voltages between terminals before wiring.
- For permanently connected UPS systems, ensure that cover plates on all units are installed before providing power to the UPS system.
- Ensure that all units in the UPS system (includes UPS, EBP, MBS, etc.) are properly grounded before power is applied to the system, refer to Section 4 – Electrical Connections in this document.
- It is recommended to install external isolators on the UPS system to prevent back-feed on the input from the battery if an internal UPS fault occurs.
- When installing the equipment, ensure that the sum of the leakage current

of the UPS and the connected devices does not exceed 3.5mA.

- Do not connect appliances or devices which would overload the UPS system to the UPS output
- Route cables to eliminate tripping hazards.
- Do not connect domestic appliances such as hair dryers to UPS output.
- Use only UL, VDE, CE certified power cables to connect the UPS system to the building wiring source (Mains).
- Use only UL, VDE, CE certified power cables to connect the loads to the UPS system.
- The UPS cooling is dependent on fans, so it should be kept in a well-ventilated area. There are many ventilation holes on the front and rear, so they should not be blocked by any exotic obstacles.

Operation

- Do not disconnect the input (Mains) cable on the UPS system or the building wiring source, thus removing protective earth of the UPS system and of all connected loads, during operation.
- The UPS system features its own internal power source (batteries). The UPS output may be electrically live even if the UPS system input is not connected to the building source.
- The internal battery pack and EBPs must be fully charged upon initial powerup to support the full rated backup time.
- To fully disconnect the UPS system, first press and hold the OFF/Cancel button or disable the inverter from the touch screen where applicable and then disconnect the input source (Mains).
- Prevent fluids or other foreign objects from entering the UPS system.

Maintenance, service, and faults

The UPS units should only be serviced by trained qualified personnel approved by the manufacturer.

- Unit may be energized from more than one source. Each circuit must be individually disconnected before servicing.
- Caution – There is risk of electric shock even after the unit is disconnected from all input sources. Components inside the UPS system are still connected to the battery and electrically live and dangerous.
- Before performing any service and/or maintenance, disconnect the battery cartridge(s) and verify that no hazardous voltage is present on the terminals of the high voltage components such as BUS-capacitors.
- It is recommended that personnel with adequate knowledge of batteries that follow the required precautionary measures should replace the battery cartridge(s) or supervise the replacement of the battery cartridge(s).
- Caution – there is a risk of electric shock. The battery circuit is not isolated from the input voltage. Hazardous voltages may exist between the battery terminals and the ground on the UPS. Before touching, please verify that no

voltage is present.

- Batteries may cause electric shock and have a high short-circuit current. Take the precautionary measures specified below and any other measures necessary when working with the battery cartridges:
- Remove jewelry and any other metal objects.
- Use only tools with insulated grips and handles.
- Avoid touching or shorting battery cartridge terminals.
- When changing battery cartridge(s), only replace with the same battery cartridge part number as specified for that UPS.
- Do not attempt to dispose of battery cartridges by burning them. This could cause the batteries to explode.
- Do not open or destroy batteries. Escaping electrolytes can cause injury to the skin and eyes and may be toxic.
- Replace any fuses only with the same type and amperage to avoid fire hazards.
- Do not disassemble any components in the UPS system (UPS, EBP, MBS, etc.).
- Risk of electrical shock; do not touch uninsulated battery terminals.
- Risk of explosion if battery cartridge is replaced with an incorrect battery cartridge type.
- Batteries should be mounted in an environment where the temperature is within the required specs. Temperature is a major factor in determining battery life and capacity. In a normal installation, the battery temperature is maintained between 15°C and 25°C. Keep batteries away from heat sources or main air ventilation area, etc.
- Units with internal battery cartridges and battery cartridges must be stored in an environment to protect against excessive humidity and heat source.
- Typical battery performance is based on an operating temperature between 20°C and 25°C. Operating the battery cartridges above this range will reduce the battery life, while operating below this range will reduce the battery capacity.
- An unused battery cartridge must be fully recharged every 3 months.

Section 3 – UPS, EBP and MBS Mounting

The UPS, EBP and the MBS units may have different mounting options. Refer to the following section that matches the desired mounting technique desired.

Note: It is recommended prior to installation to plan on installing accessories such as EBP or MBS units near the associated UPS unit for ease of system connection.

Racks

Four-post rack mounting is the recommended mounting technique for all UPS, EBP and MBS units. The mounting hardware for this technique is provided with most units. (Refer to the part specification or item description for included contents.)

The units may also be mounted in a two-post rack, requiring additional mounting hardware specified in the below section. (**Note:** It is recommended to mount the UPS and EBP unit(s) near the bottom of the rack due to the physical weight of these units).

The third mounting option is tower mounting. This is not the preferred mounting technique, but tower mounting stands are provided with most units. The 3-Phase UPS and EBP units should not use this mounting technique due to the physical configuration and physical weight of the unit.

Four-Post Racks - Installation

The UPS, EBP and MBS units come with the hardware required for installation in a standard EIA or JIS seismic rated four-post rack with square or M5 threaded mounting holes. The rail assemblies adjust to mount in 19" racks with a front to rear distance of 460 to 1000 mm (18 to 39 inches).

CAUTION



- *The unit is heavy. Removing the unit from its carton requires a minimum of two people.*
- *When installing optional EBP(s), make sure to install the EBP(s) directly below the UPS so the wiring between the units can use the wiring provided with the units.*

Note: *Mounting rails are required for each individual unit.*

Install 2U UPS Units (U01N11L, U01N11V, U01S11L, U01S11V, U01N12L, U01N12V, U01S12L, U01S12V, U01N13V, U01S13V, U01N14L, U01S14L, U01N16L-N, U01N18L-N, U02N11L, U02N11V, U02S11L, U02S11V, U02N12L, U02N12V, U02S12L, U02S12V, U02N14L, U02N16L-N, U02N18L-N, U02S14L, U03N11L, U03N11V, U03S11L, U03S11V, U03N12L, U03N12V, U03S12L, U03S12V, U03N14L, U03S14L, U03N15L, U03S15L, U03N16L-N, U03N18L-N, U05N11L, U05S11L, U06N11L, U06S11L, U10N11L, U10S11L, U05N12L, U05S12L, U06N12L, U06S12L, U10N12L, U10S12L)

Install the URMKIT2 rail kit:

- Install the front side of the rail kit with 3x Phillips Pan Head M5 screws (see figure below) on each rail. Do not tighten the screws.

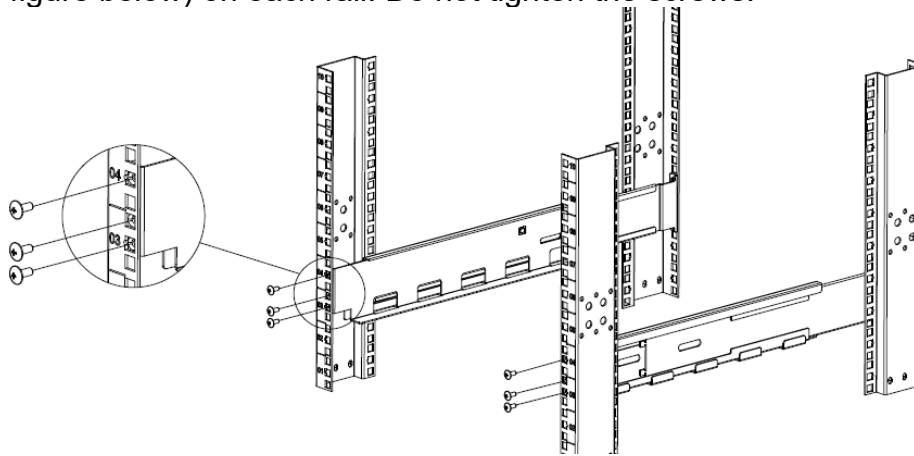

Figure 1: Install the Front Side of Rails

- Adjust the rail size according to the depth of the rack
- Install the rear side of the rail kit with 3x Phillips Pan Head M5 screws (see figure below) on each rail.

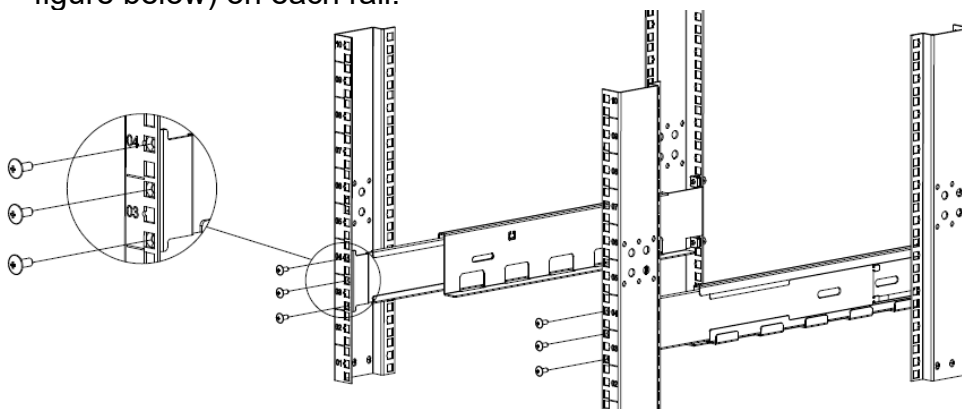

Figure 2: Install the Rear Side of Rails

- Tighten all 12x screws to secure the left and right rails to the rack.
- Install the 4x M5 cage nuts in the rack front equipment rail, with square holes. Install one in each of the first locations below the bottom rail kit screw and one in each of the first locations above the top rail kit screw (see figure below).

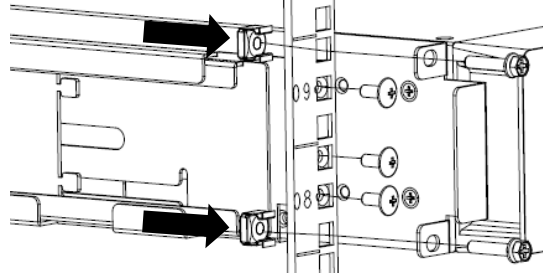

Figure 3: Install Cage Nuts in the Front Equipment Rail with Square Holes

For 2U Units with internal battery cartridges: (P/Ns: U01N11L, U01N11V, U01S11L, U01S11V, U01N12L, U01N12V, U01S12L, U01S12V, U01N13V, U01S13V, U01N14L, U01S14L, U02N11L, U02N11V, U02S11L, U02S11V, U02N12L, U02N12V, U02S12L, U02S12V, U02N14L, U02S14L, U03N11L, U03N11V, U03S11L, U03S11V, U03N12L, U03N12V, U03S12L, U03S12V, U03N14L, U03S14L, U03N15L, U03S15L):

- Remove the faceplate:
- Press both sides of UPS faceplate until the latches release (see figure below).
- Remove the faceplate (see figure below).

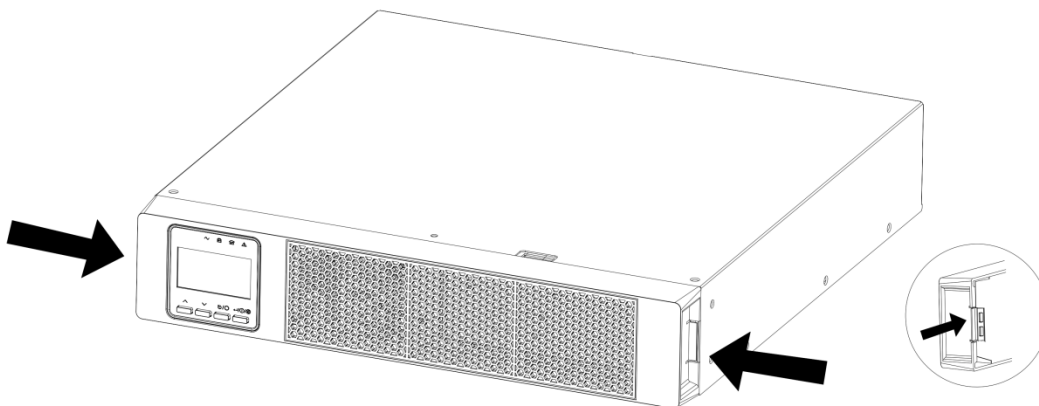

Figure 4: Press the Latches to Remove Faceplate

- Remove the faceplate (see figure below).

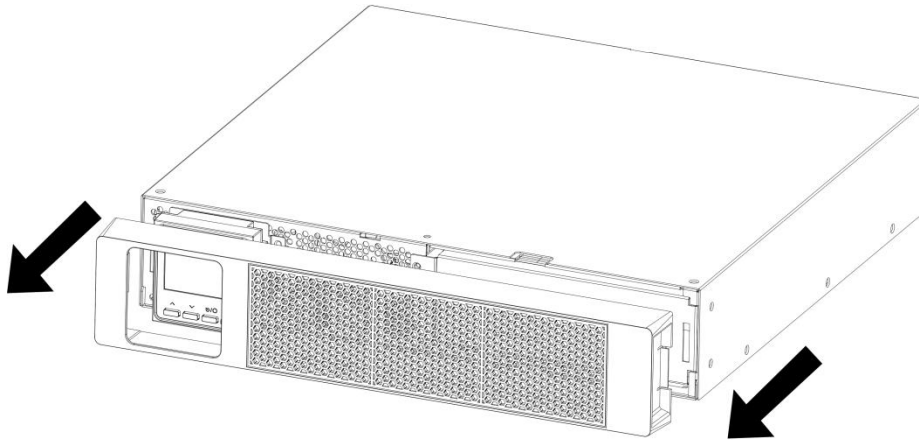

Figure 5: Remove the Faceplate

- Make sure the screen is rotated in the proper orientation for mounting in a rack. The screen may be manually rotated ¼ turn for rack or tower mounting.
- Connect the internal battery cartridge:
- Connect the internal battery cartridge connector (see figure below). Press the connector tightly together to ensure a proper connection.

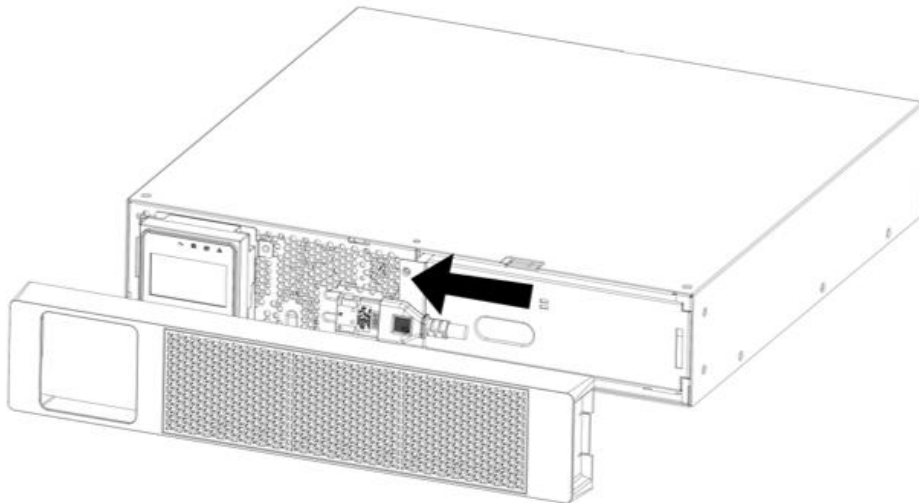

Figure 6: Connect the Internal Battery Cartridge Connector

- Reinstall the faceplate on the UPS, by aligning the front panel display through the hole in the faceplate and snapping the faceplate onto the front of the UPS. Should have a positive snap of the latches on the faceplate.



CAUTION



A small amount of arcing may occur when connecting the internal battery cartridge. This is normal and will not harm personnel. Connect the cables quickly and firmly.

For 2U UPS units (P/Ns: U01N11L, U01N11V, U01S11L, U01S11V, U01N12L, U01N12V, U01S12L, U01S12V, U01N13V, U01S13V, U01N14L, U01S14L, U01N16L-N, U01N18L-N, U02N11L, U02N11V, U02S11L, U02S11V, U02N12L, U02N12V, U02S12L, U02S12V, U02N14L, U02S14L, U02N16L-N, U02N18L-N, U03N11L, U03N11V, U03S11L, U03S11V, U03N12L, U03N12V, U03S12L, U03S12V, U03N14L, U03S14L, U03N15L, U03S15L, U03N16L-N, U03N18L-N, U05N11L, U05S11L, U06N11L, U06S11L, U10N11L, U10S11L, U05N12L, U05S12L, U06N12L, U06S12L, U10N12L, U10S12L):

- Install the mounting brackets:
 - Remove the 2x Phillips Flat Head M4x8 screws from the front of each side of the unit and retain.
 - Align the mounting brackets with the screw holes on each side of the unit and secure with the previously removed Phillips Flat Head M4x8 screws (see figure below).

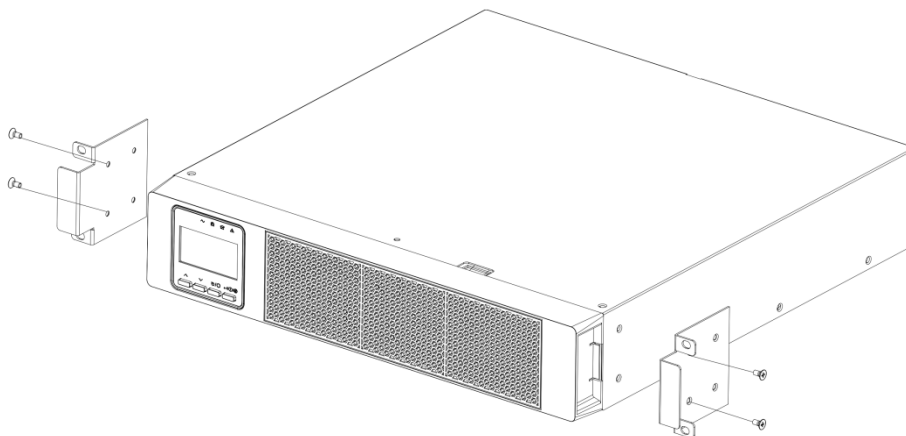

Figure 7: Install the Mounting Bracket

- Install the unit into the rack.
- After installing the mounting brackets onto the unit, slide the unit into the rack on the rail kit (see figure below).

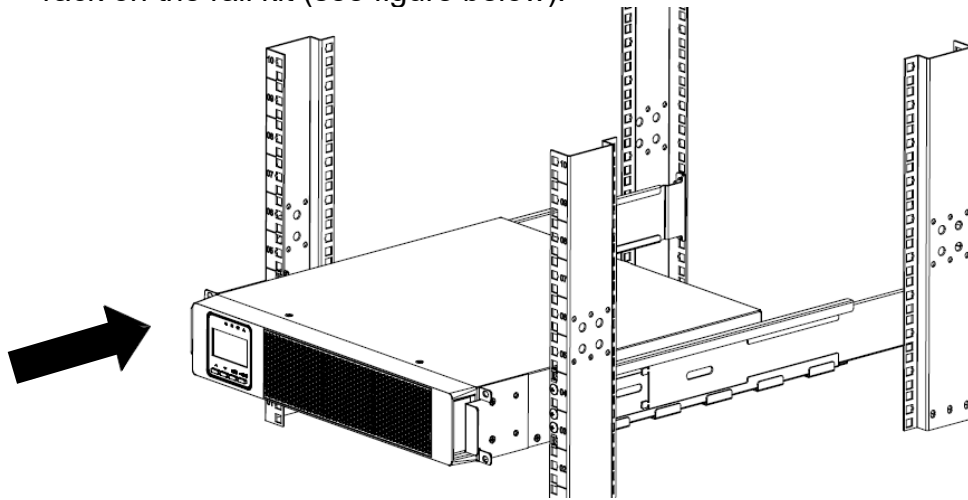

Figure 8: Slide the unit into the Rack (UPS example shown)

- Align the mounting brackets with the screw holes on the rack and secure the UPS with the supplied 4x Phillips Hex Head M5 screws (see figure below).
- **Note:** For installation in a rack with #12-24 threaded mounting holes, it is recommended to use Panduit part number **S1224-C** during this step when attaching the mounting ears.

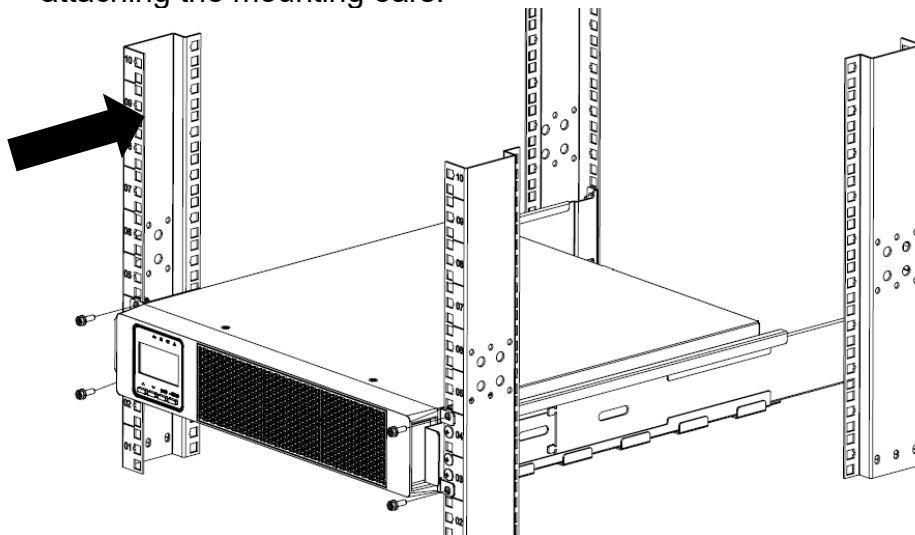

Figure 9: Secure the Mounting Brackets to the Rack

Install 2U EBP Units (UVP024, UVP036, UVP048, UVP072, UVPL12H, UVPL50H)

It is recommended to install the first EBP unit directly under the UPS unit. It is recommended to install all subsequent EBP units directly under the previous EBP unit.

- Install the URMKIT2 rail kit:
- Install the front side of the rail kit with 3x Phillips Pan Head M5 screws (see figure below) on each rail. Do not tighten the screws.
-

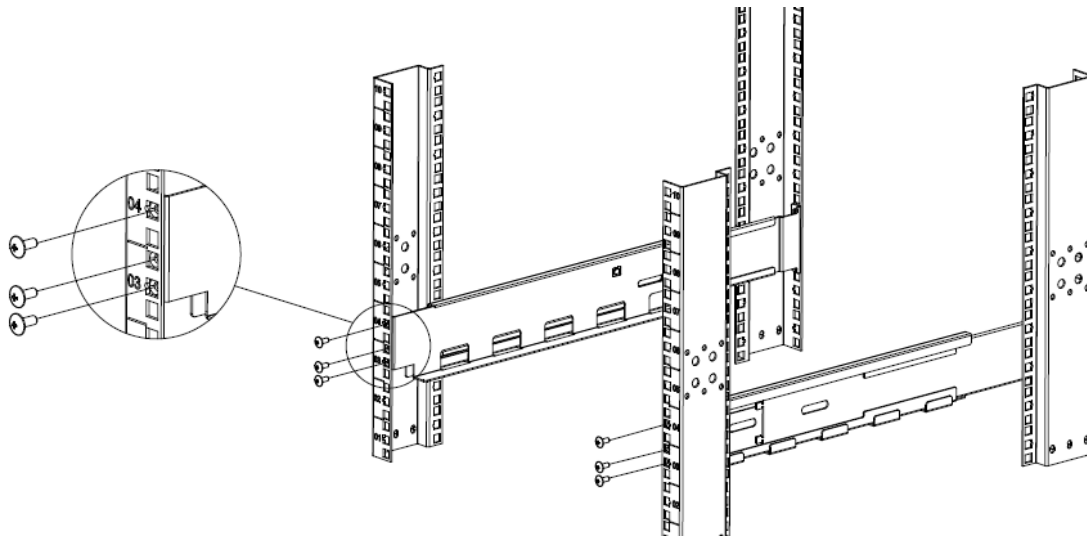

Figure 10: Install the Front Side of Rails

Adjust the rail size according to the depth of the rack.

- Install the rear side of the rail kit with 3x Phillips Pan Head M5 screws (see figure below) on each rail.

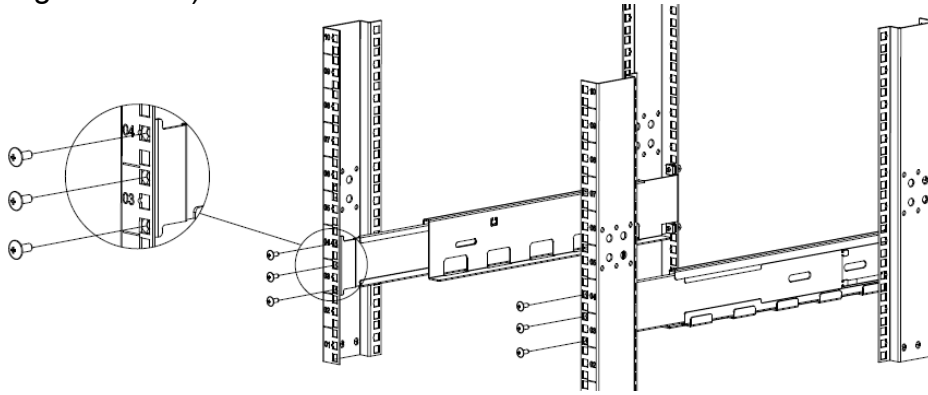

Figure 11: Install the Rear Side of Rails

- Tighten all 12x screws to secure the rail kit to the rack.
- Install the 4x M5 cage nuts in the rack front equipment rail, with square holes. One in each of the first locations below the bottom rail kit screw and one in each of the first locations above the top rail kit screw (see figure below).

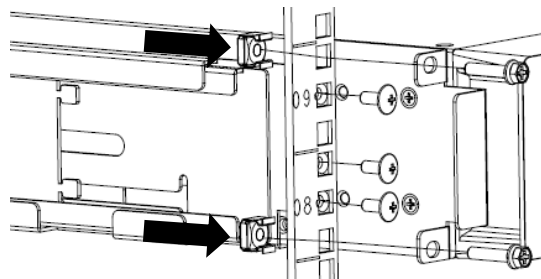

Figure 12: Install Cage Nuts in the Front Equipment Rail with Square Holes

For 1-3kVA UPS VRLA External Battery Packs (P/Ns: UVP024, UVP036, UVP048, UVP072):

- Remove the faceplate:
- Press both sides of EBP faceplate until the latches release and remove (see figure below).

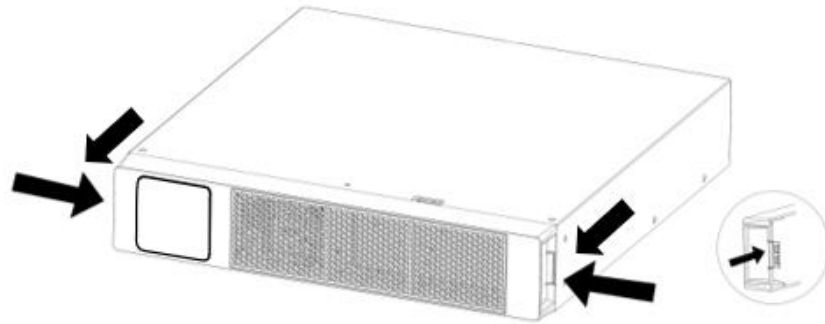

Figure 13: Press the Latches and Remove Faceplate

- Connect the internal battery cartridges:
- Remove and retain the two screws on top and bottom each battery cover near the center of the unit, slide the battery cover toward the center, and then remove and retain (see figure below).

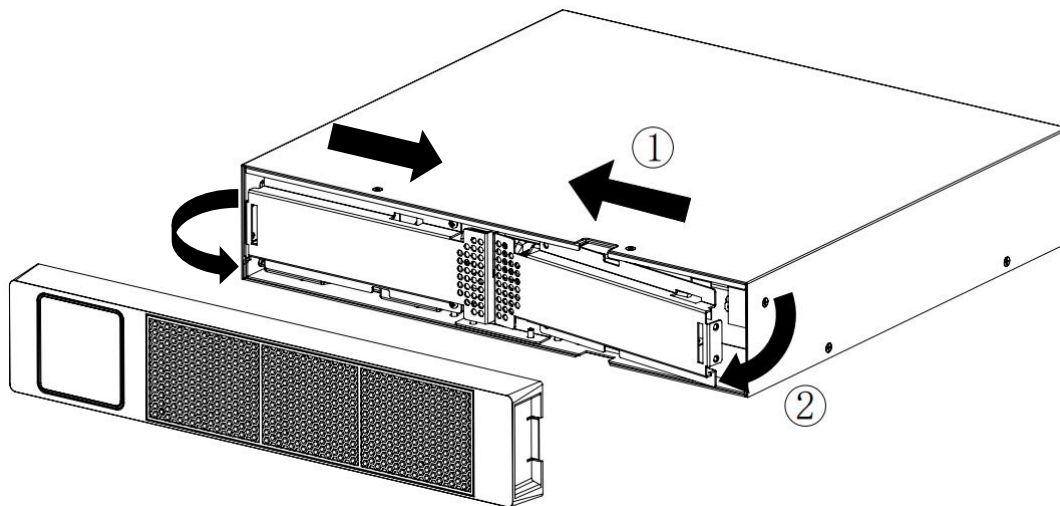

Figure 14: Remove the Faceplate

- Pull both battery cartridge connectors through the middle hole in the chassis and connect a battery cartridge to each connector (see figure below). Press the connector tightly together to ensure a proper connection. Connect the other battery cartridge in the EBP. Both internal battery cartridges should be connected. Press each connector tightly together to ensure a proper connection.

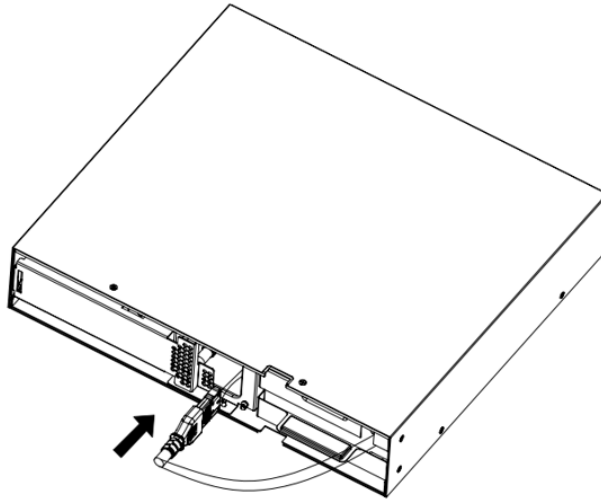

Figure 15: Connect the First Internal Battery Cartridge Connector

- Insert the connectors back into the middle hole on the chassis.
- Reinstall and secure the retained battery covers in reverse order of above step.
- Reinstall the faceplate on the EBP, by aligning the front panel latches with the holes in the front of the unit and snapping the faceplate onto the front of the EBP unit. Should have a positive snap of the latches on the faceplate.

For 2U EBP Units (P/Ns: UVP024, UVP036, UVP048, UVP072, UVPL12H, UVPL50H):

- Install the mounting brackets:
- Remove the 2x Phillips Flat Head M4x8 screws from the front of each side of the EBP and retain.
- Align the mounting brackets with the screw holes on each side of the EBP and secure with the previously removed Phillips Flat Head M4x8 screws (see figure below).

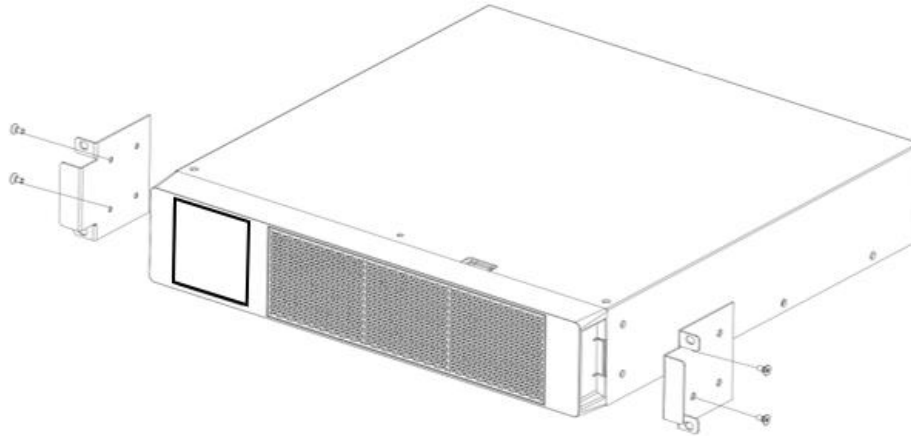

Figure 16: Install the Mounting Bracket

- Install the EBP unit into the rack:
- After installing the mounting brackets onto the EBP, slide the EBP unit into the rack on the rail kit (see figure below).

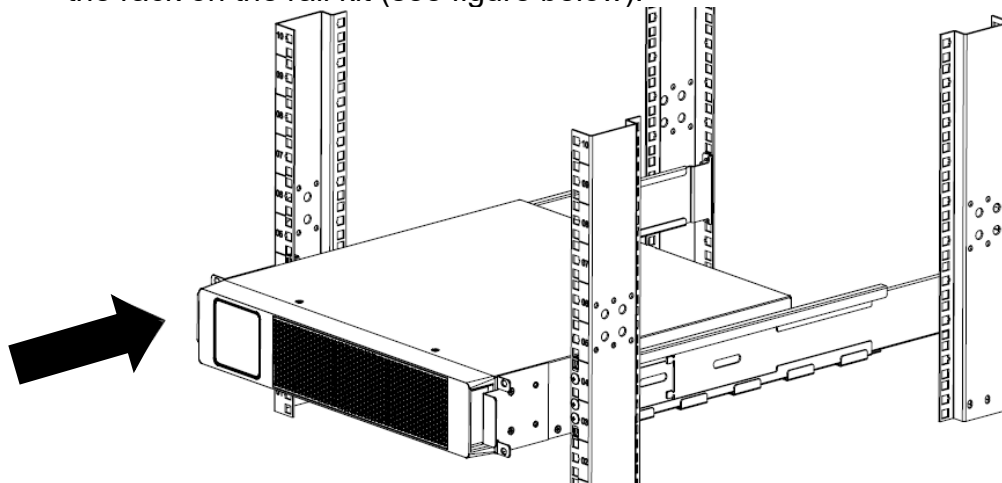

Figure 17: Slide EBP into the Rack

- Align the mounting brackets with the screw holes on the rack and secure the EBP unit with the supplied 4x Phillips Hex Head M5 screws (see figure below).
- **Note:** For installation in a rack with #12-24 threaded mounting holes, it is recommended to use Panduit part number **S1224-C** during this step when attaching the mounting ears.

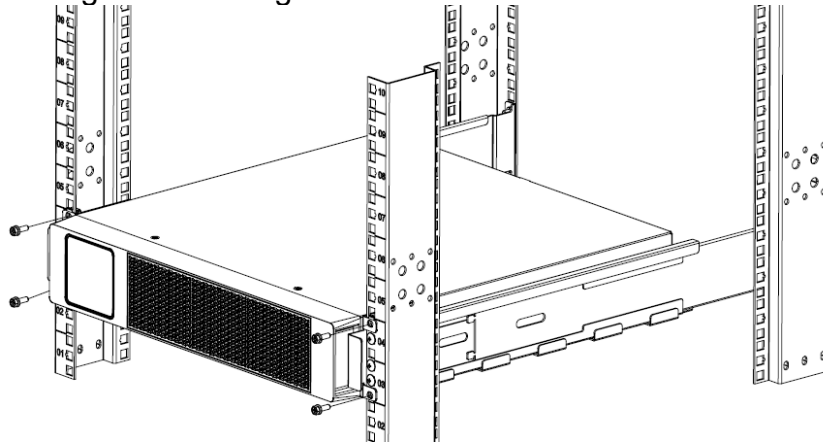

Figure 18: Secure the Mounting Brackets to the Rack

Install 3U UPS Units (U05N11V, U05S11V, U06N11V, U06S11V, U06N12V, U06S12V, U10N11V, U10S11V, U10N12V, U10S12V, U10N32V, U10S32V, U15N32V, U15S32V, U20N32V, U20S32V)

- Install the URMKIT2 rail kit:
- Install the front side of the rail kit with 2x Phillips Pan Head M5 screws (see figure below) on each rail. Do not tighten the screws.

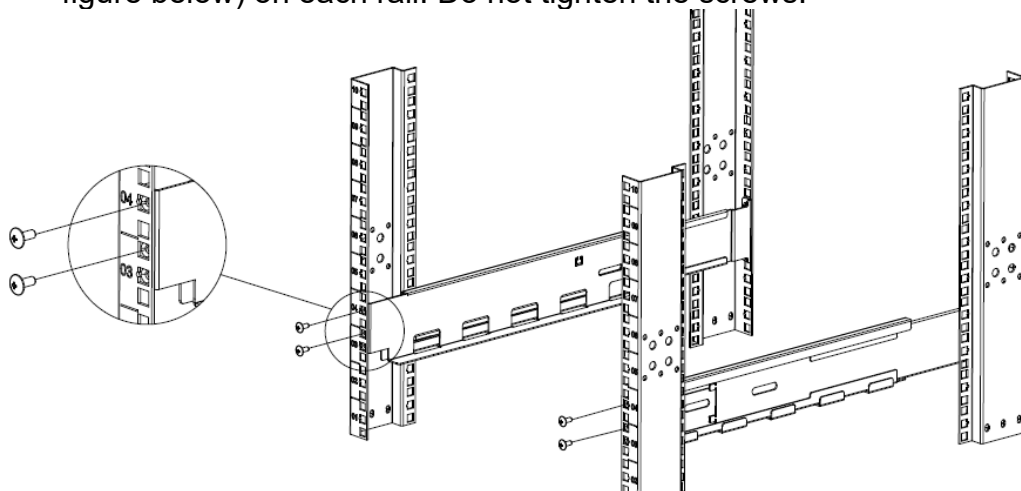

Figure 19: Install the Front Side of Rails

- Install the front side of the rail kit with 2x Phillips Pan Head M5 screws (see figure below) on each rail. Do not tighten the screws.
- Adjust the rail size according to the depth of the rack
- Install the rear side of the rail kit with 3x Phillips Pan Head M5 screws (see figure below) on each rail.

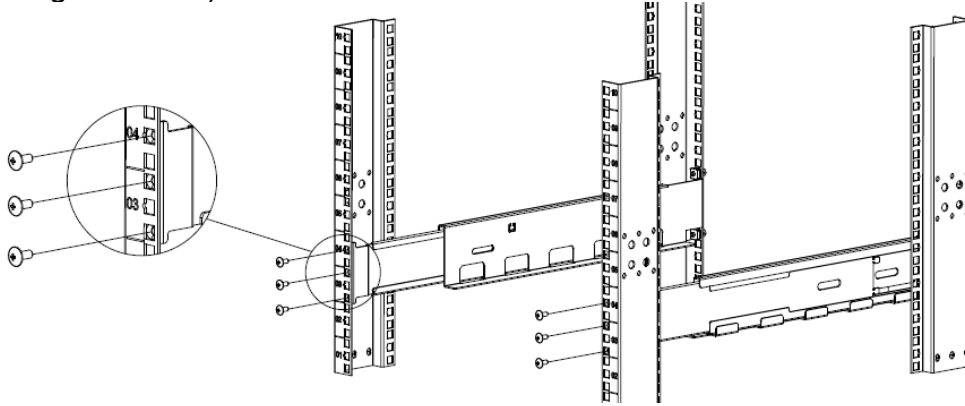

Figure 20: Install the Rear Side of Rails

- Tighten all 10x screws to secure the rail kit to the rack.
- Install the 2x M5 cage nuts in the rack front equipment rail, with square holes. One in each of the third locations above the top rail kit screw (see figure below).

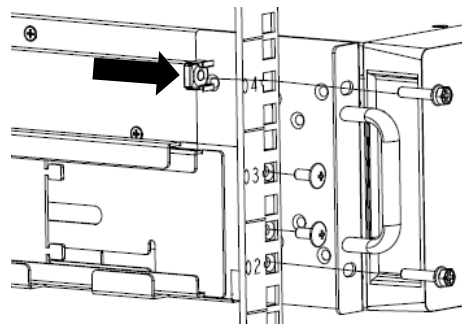

Figure 21: Install Cage Nuts in the Front Equipment Rail with Square Holes

- Install the mounting brackets:
- Remove the 4x Phillips Flat Head M4x8 screws from the front of each side of the UPS and retain.
- Align the mounting brackets with the screw holes on each side of the UPS and secure with the previously removed Phillips Flat Head M4x8 screws (see figure below).

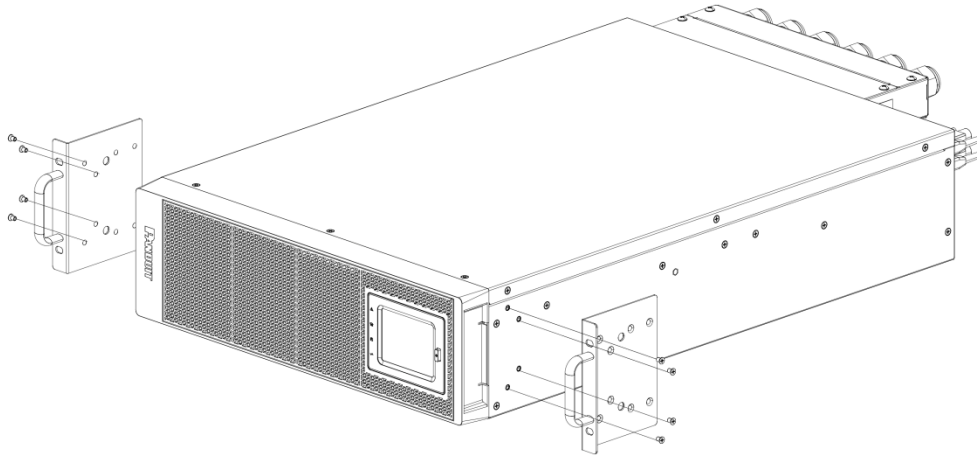

Figure 22: Install the Mounting Bracket

- Install the UPS unit into the rack:
- After installing the mounting brackets onto the UPS, slide the UPS unit into the rack on the rail kit (see figure below).

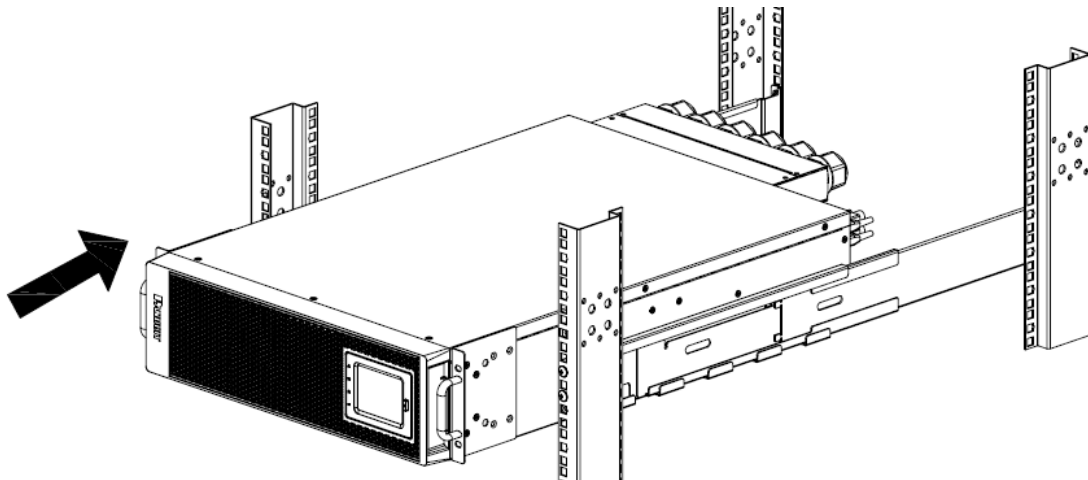

Figure 23: Slide UPS into the Rack

- Align the mounting brackets with the screw holes on the rack and secure the UPS with the supplied 4x Phillips Hex Head M5 screws (see figure below).

Note: The top Phillips Hex Head M5 screws will screw into the cage nuts. The bottom Phillips Hex Head M5 screws will screw into the threaded rails.

- **Note:** For installation in a rack with #12-24 threaded mounting holes, it is recommended to use Panduit part number **S1224-C** during this step when attaching the mounting ears.

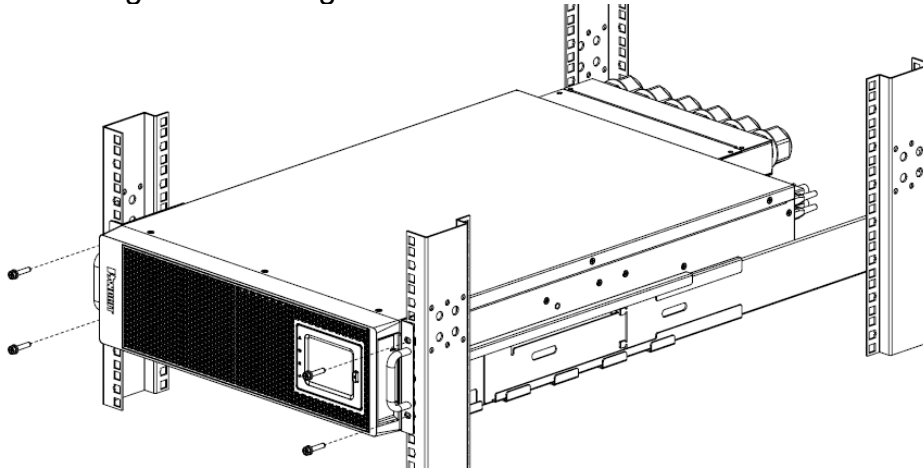

Figure 24: Secure the Mounting Brackets to the Rack

Install 3U EBP Unit (UVP240)

It is recommended to install the EBP unit directly under the UPS unit. It is recommended to install all subsequent EBP units directly under the previous EBP unit.

- Install the URMKIT2 rail kit:
- Install the front side of the rail kit with 2x Phillips Pan Head M5 screws (see figure below) on each rail. Do not tighten the screws.

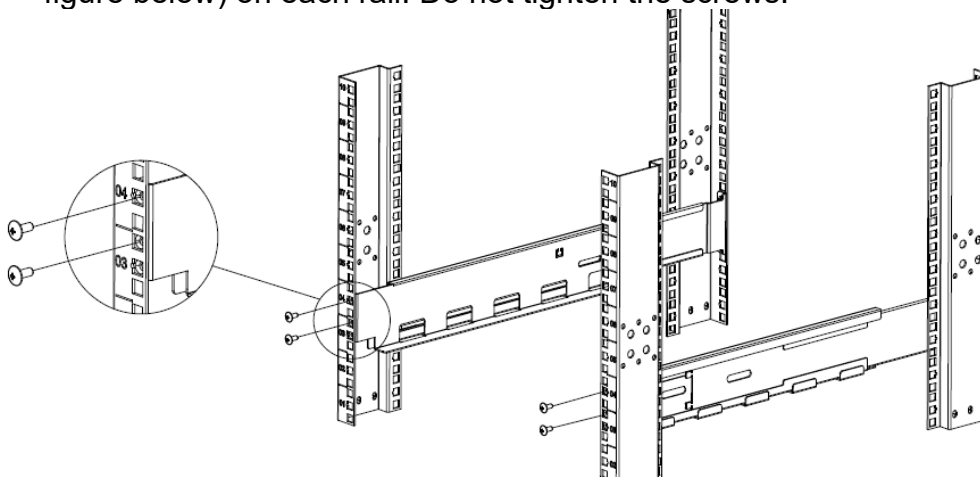



Figure 25: Install the Front Side of Rails

- Adjust the rail size according to the depth of the rack

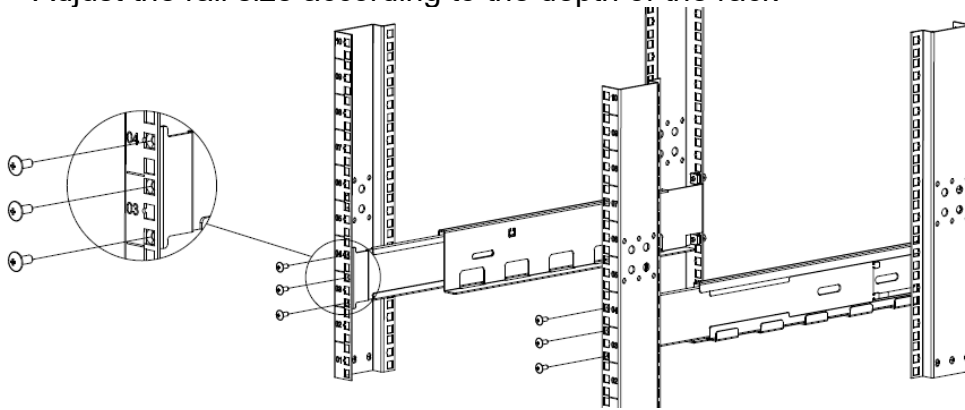

Figure 26: Install the Rear Side of Rails

- Install the rear side of the rail kit with 3x Phillips Pan Head M5 screws (see figure below) on each rail. Tighten all 10x screws to secure the rail kit to the rack.
- Install the 2x M5 cage nuts in the rack front equipment rail, with square holes. Install one in each of the third locations above the top rail kit screw (see figure below).

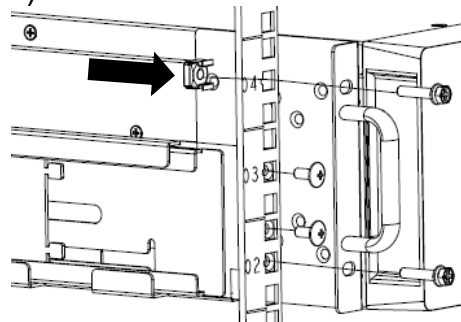

Figure 27: Install Cage Nuts in the Front Equipment Rail with Square Holes

- Remove the faceplate:
- Press both sides of EBP faceplate until the latches release (see figure below). Then remove the faceplate from the front of the unit.

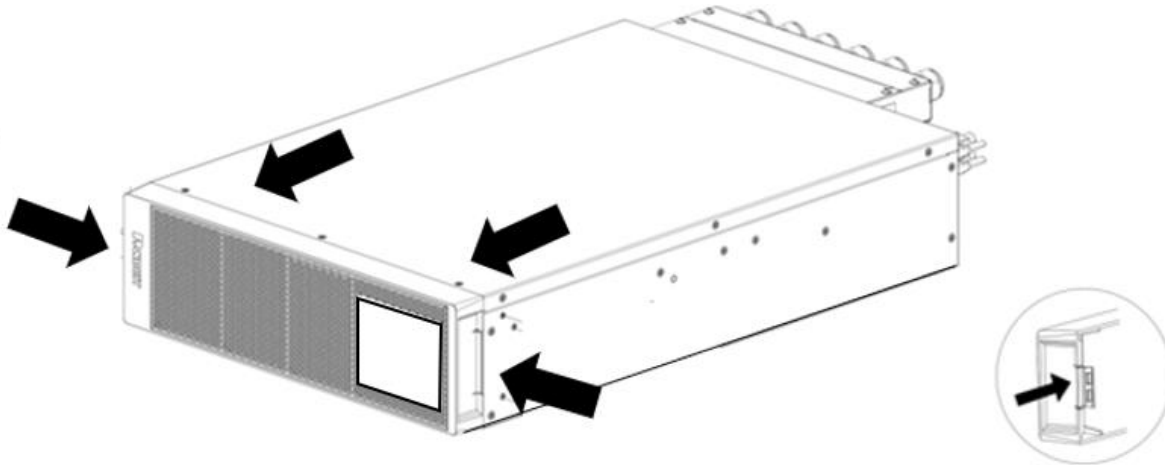

Figure 28: Press the Latches to Remove Faceplate

- Install the mounting brackets:
- Remove the 4x Phillips Flat Head M4x8 screws from the front of each side of the EBP and retain.
- Align the mounting brackets with the screw holes on each side of the EBP and secure with the previously removed Phillips Flat Head M4x8 screws (see figure below).

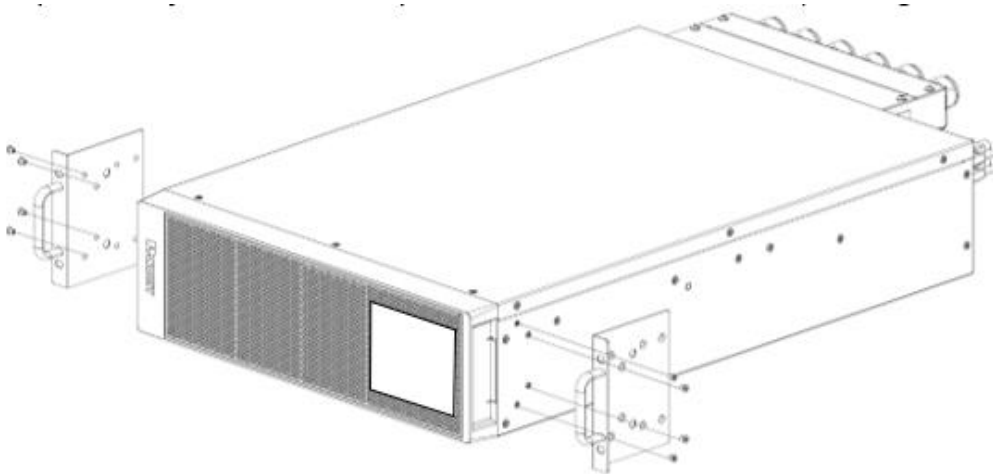

Figure 29: Install the Mounting Bracket

- Remove the Battery Cartridges:
- Due to the weight of the battery cartridges, it is recommended to remove them from the EBP unit before attempting to install the EBP unit in the rack.
- Disconnect all battery cartridge connectors (see figure below).

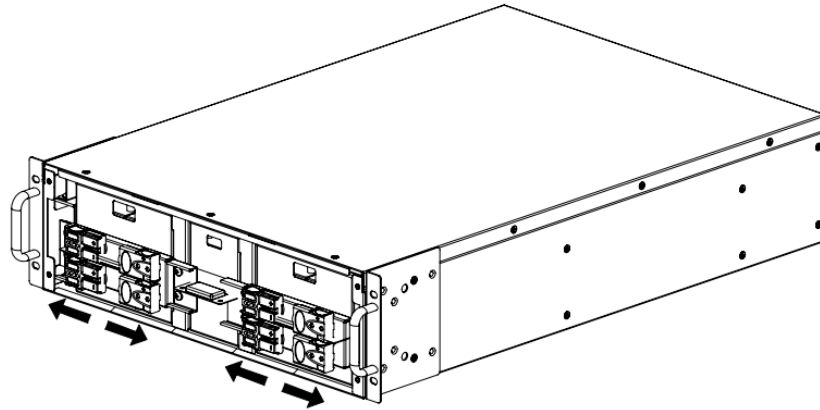

Figure 30: Disconnect Internal Battery Cartridges

- Remove and retain the 4x battery baffle screws from each battery baffle. Remove and retain the battery baffles (see figure below).

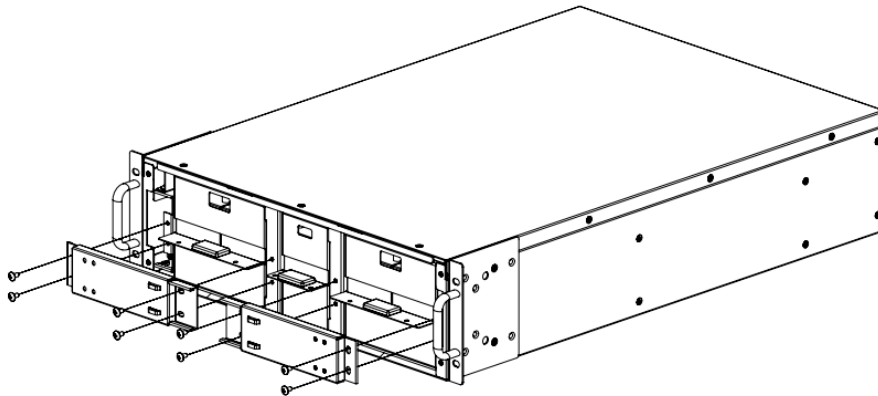

Figure 31: Remove the Battery Baffles

- Refer to the handling instruction, take out all three battery cartridges (see figure below). Two larger battery cartridges and one smaller battery cartridge and retain.

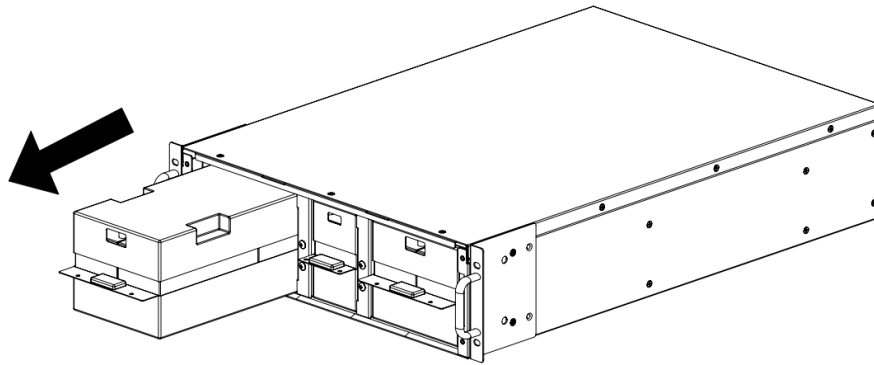

Figure 32: Remove Battery Cartridges from EBP

- Install the EBP chassis into the rack:
- Slide the EBP unit into the rack on the rail kit (see figure below).

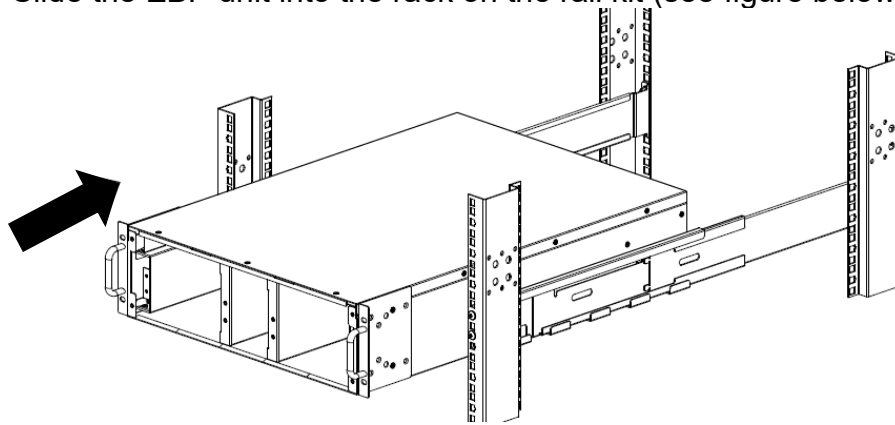

Figure 33: Slide EBP into the Rack

- Align the mounting brackets with the screw holes on the rack and secure the EBP with the supplied 4x Phillips Hex Head M5 screws (see figure below). **Note:** The top Phillips Hex Head M5 screws will screw into the cage nuts. The bottom Phillips Hex Head M5 screws will screw into the threaded rails.
- **Note:** For installation in a rack with #12-24 threaded mounting holes, it is recommended to use Panduit part number **S1224-C** during this step when attaching the mounting ears.

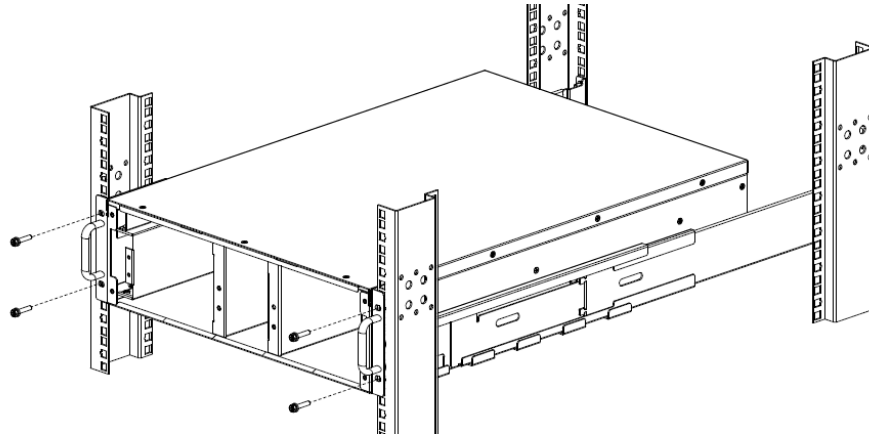

Figure 34: Secure the Mounting Brackets to the Rack

- Reinstall battery cartridges:
- Refer to the handling instructions and reinsert the battery cartridges into the EBP unit (see figure below).

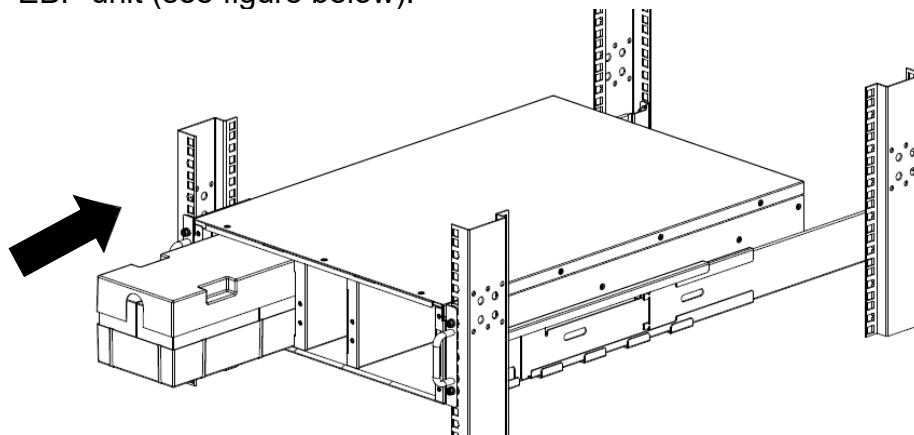

Figure 35: Reinsert the Battery Cartridges into the EBP Unit

- Reinstall the battery baffles the screws (see figure below).

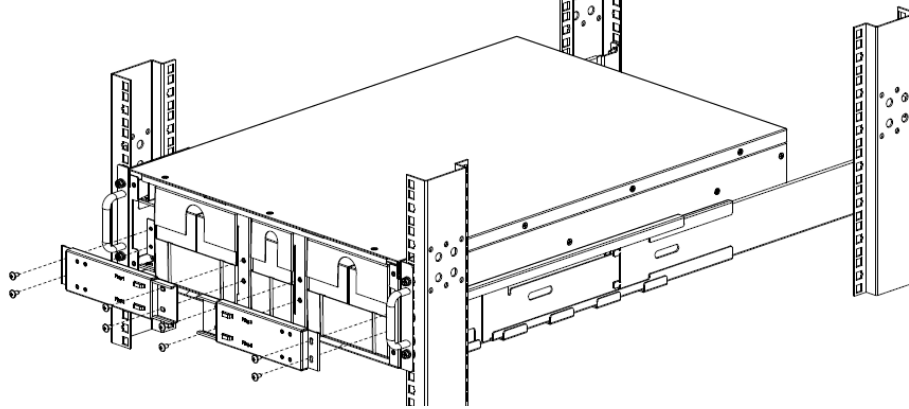

Figure 36: Reinstall Battery Baffles and Screws

- Reconnect the Battery Cartridge connectors (see figure below). Press each connector tightly together to ensure a proper connection.
- The larger battery cartridges connect to connectors 1 and 3, each half of the smaller battery cartridge connect to connectors 2 and 4.

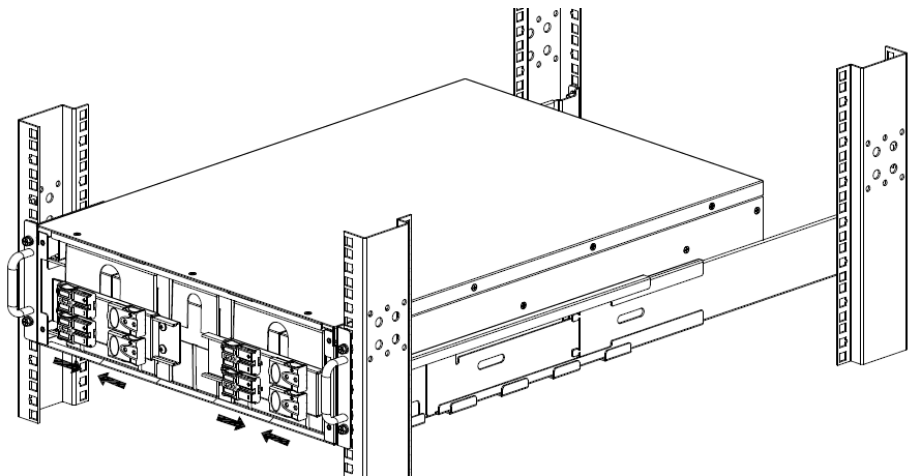

Figure 37: Reconnect EBP Battery Cartridge Connectors

- Reinstall the faceplate on the EBP unit, by aligning the front panel latches with the holes in the front of the unit and snapping the faceplate onto the front of the EBP. Should have a positive snap of the latches on the faceplate.

Install 3U MBS Unit (UMB20K)

Note: It is recommended to install the MBS directly above the associated UPS for ease of system connection.

- Install the URMKIT2 rail kit:
- Install the front side of the rail kit with 2x Phillips Pan Head M5 screws (see figure below) on each rail. Do not tighten the screws.

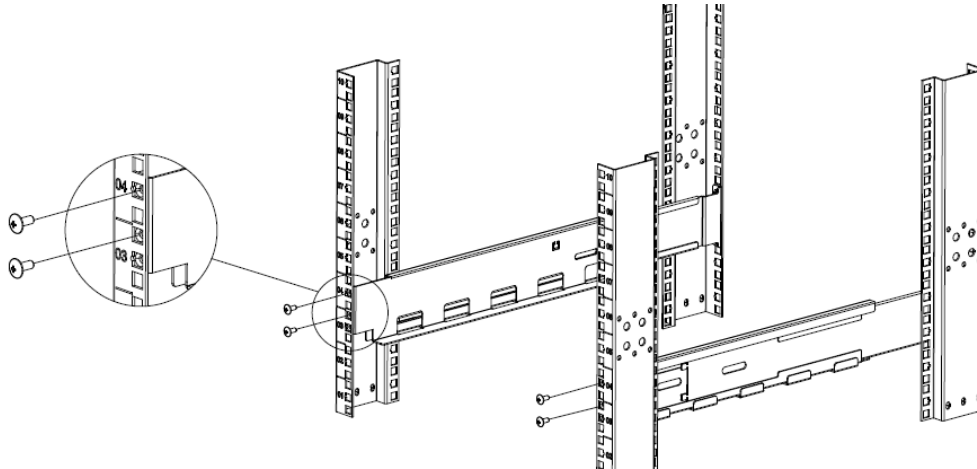

Figure 38: Install the Front Side of Rails

- Adjust the rail size according to the depth of the rack
- Install the rear side of the rail kit with 3x Phillips Pan Head M5 screws (see figure below) on each rail.

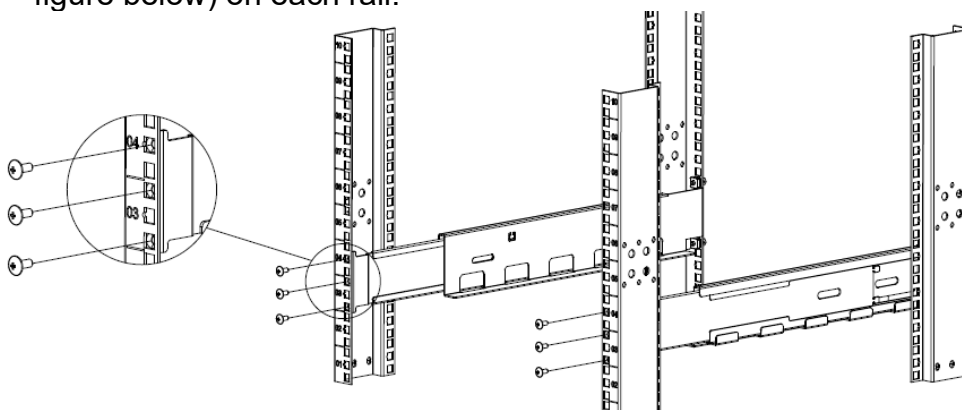

Figure 39: Install the Rear Side of Rails

- Tighten all 10x screws to secure the rail kit to the rack.
- Install the 2x M5 cage nuts in the rack front equipment rail, with square holes. One in each of the first locations below the bottom rail kit screw and one in each of the third locations above the top rail kit screw (see figure below).

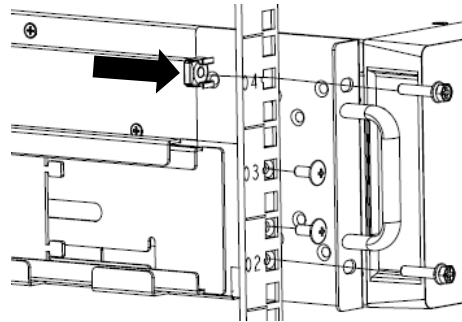

Figure 40: Install Cage Nuts in the Front Equipment Rail with Square Holes

- Install the mounting brackets:
- Remove the 2x Phillips Flat Head M4x8 screws from the front of each side of the MBS and retain.
- Align the mounting brackets with the screw holes on each side of the MBS and secure with the previously removed Phillips Flat Head M4x8 screws (see figure below).

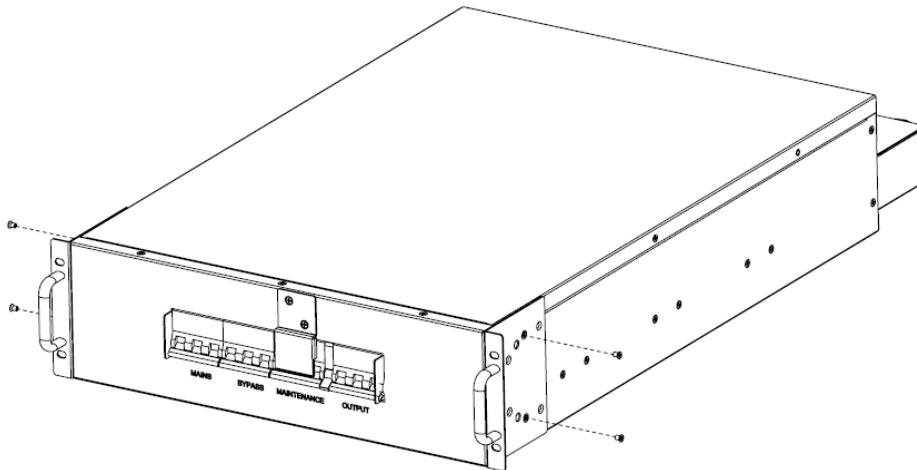

Figure 41: Install the Mounting Bracket

- Install the MBS unit into the rack:
- After installing the mounting brackets onto the MBS, slide the MBS into the rack on the rail kit (see figure below).

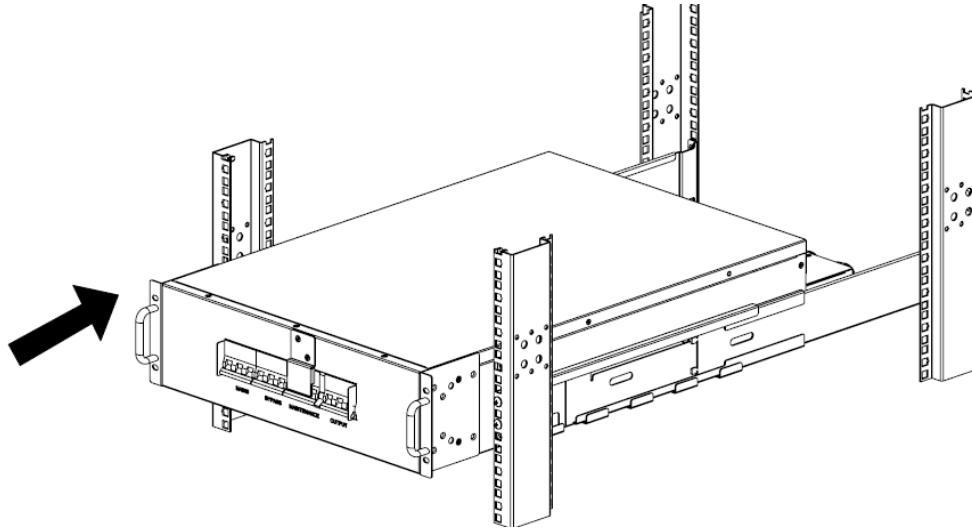

Figure 42: Slide MBS into the Rack

- Align the mounting brackets with the screw holes on the rack and secure the MBS with the supplied 4x Phillips Hex Head M5 screws (see figure below). **Note:** The top Phillips Hex Head M5 screws will screw into the cage nuts. The bottom Phillips Hex Head M5 screws will screw into the threaded rails.
- **Note:** For installation in a rack with #12-24 threaded mounting holes, it is recommended to use Panduit part number **S1224-C** during this step when attaching the mounting ears.

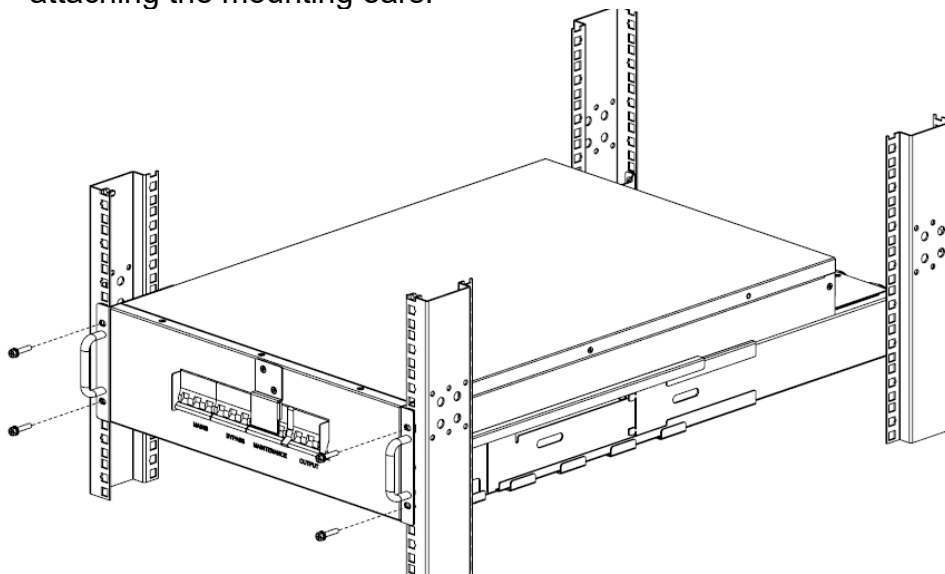

Figure 43: Secure the Mounting Brackets to the Rack

Install 4U EBP Unit (UVP480)

It is recommended to install the EBP unit directly under the UPS unit. It is recommended to install all subsequent EBP units directly under the previous EBP.

- Install the URM480 rail kit:
- Install the 8x M5 cage nuts in the rack front equipment rail, with square holes. One behind the holes in each rail kit rail. One behind the slot in the in each rail kit rail. One behind the first equipment rail hole above each rail kit rail (see figure below).

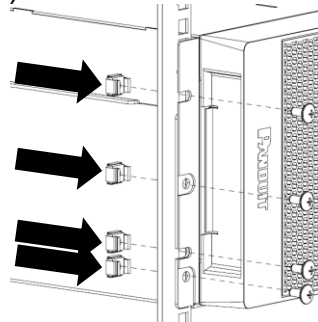

Figure 44: Install Cage Nuts in the Front Equipment Rail with Square Holes

- Install the 4x M5 cage nuts in the rack rear equipment rail, with square holes. One behind the lowest slot in each rail kit rail and one behind the third slot (one down from the top slot) in the in each rail kit rail (see figure below).

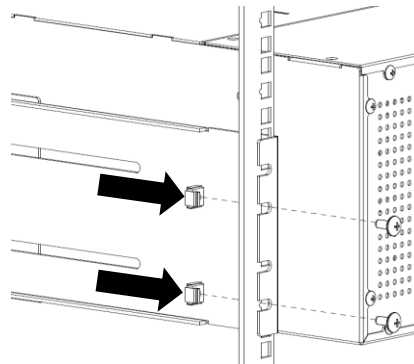

Figure 45: Install Cage Nuts in the Rear Equipment Rail with Square Holes

- Install the front side of the rail kit with 2x Phillips Pan Head M5x12 screws (see figure below) on each rail. Do not tighten the screws.

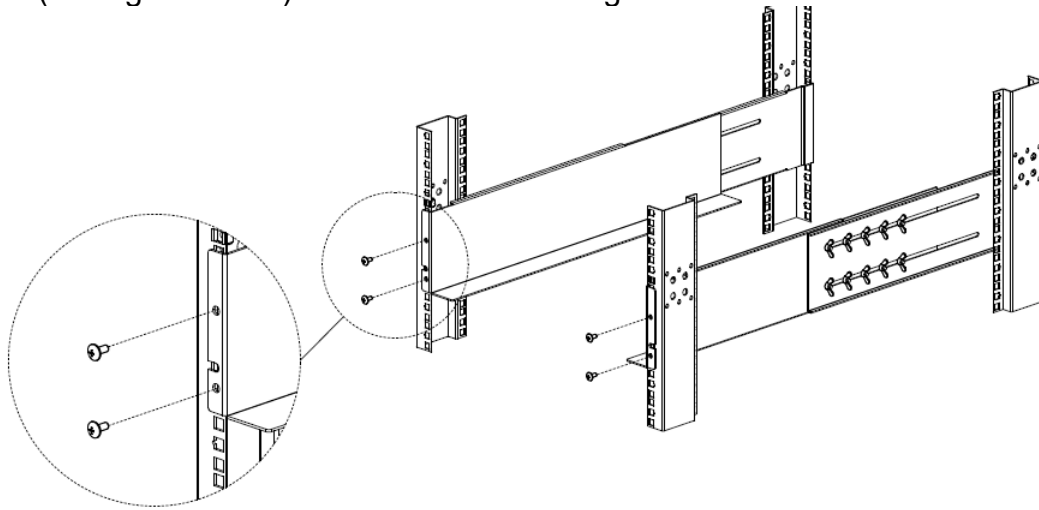

Figure 46: Install the Front Side of Rails

- Adjust the rail size according to the depth of the rack
- Install the rear side of the rail kit with 2x Phillips Pan Head M5x12 screws (see figure below) on each rail.

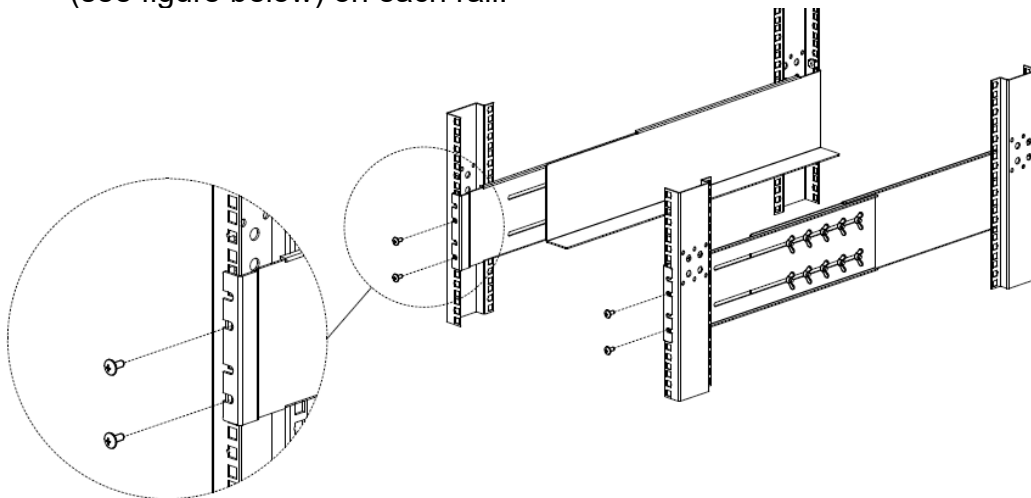

Figure 47: Install the Rear Side of Rails

- Tighten all 8x screws to secure the rail kit to the rack.
- Tighten all 10x wing nuts on the outside of each rail.
- Remove the faceplate:
- Press both sides of EBP faceplate until the latches release (see figure below). Then remove the faceplate from the front of the unit.

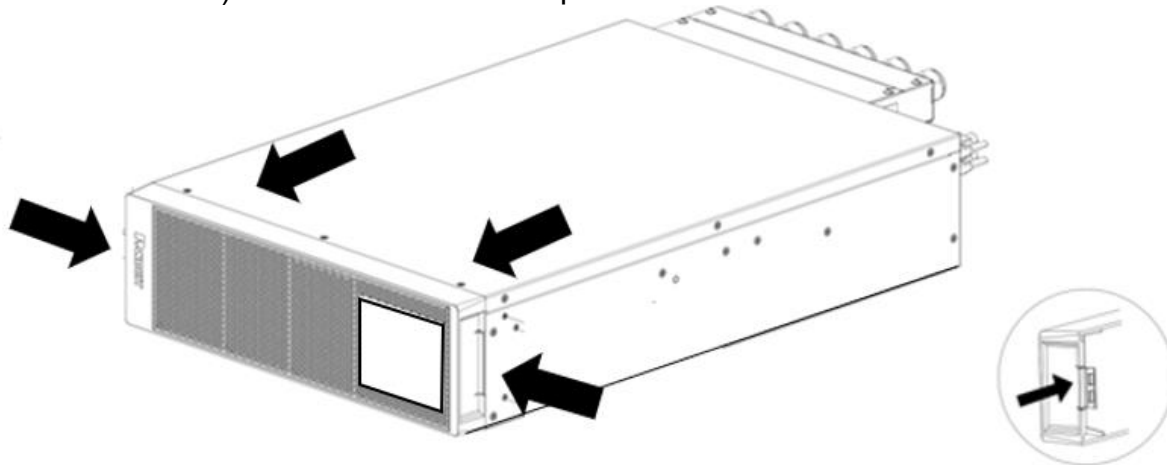

Figure 48: Press the Latches to Remove Faceplate

- Remove the Battery Cartridges:
- Due to the weight of the battery cartridges, it is recommended to remove them from the EBP unit before attempting to install the EBP unit in the rack.
- Remove and retain the 8x screws and battery baffle from EBP (see figure below).

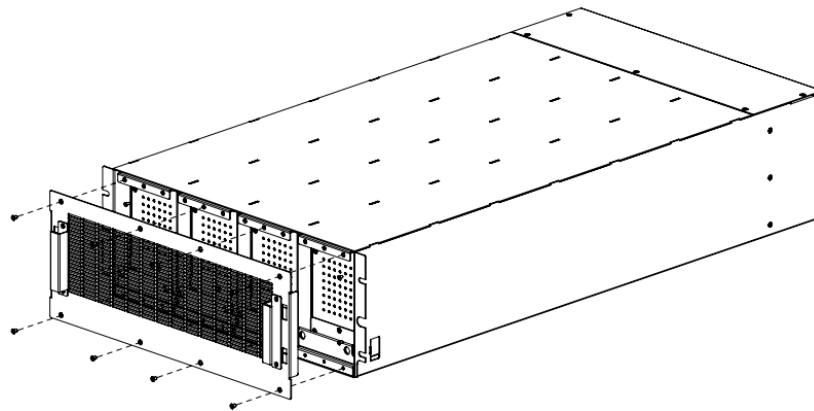

Figure 49: Remove Battery Baffle on the EBP

- Refer to the handling instruction and remove all battery cartridges (see figure below).

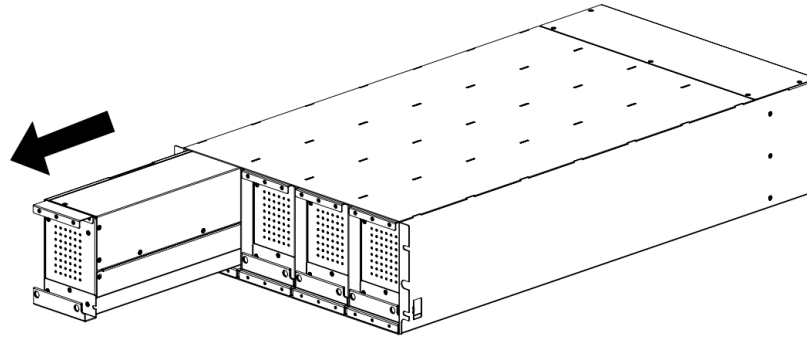

Figure 50: Remove Battery Cartridges from EBP

- Install the EBP chassis into the rack:
- Slide the EBP chassis into the rack on the rail kit (see figure below).

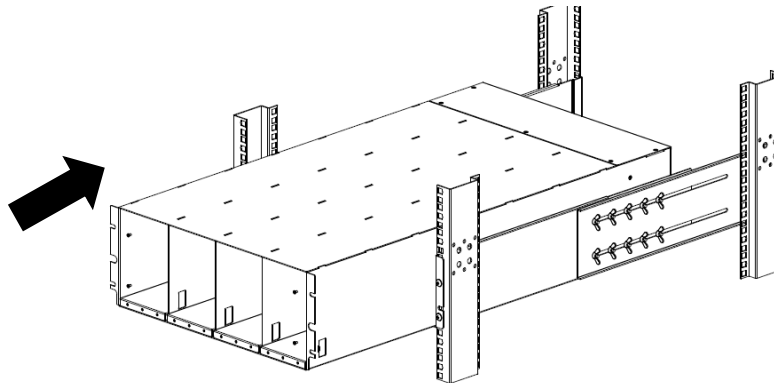

Figure 51: Slide EBP into Rack

- Align the mounting brackets with the screw holes on the rack and secure the EBP with the supplied 4x Phillips Pan Head M5 screws (see figure below).
- **Note:** For installation in a rack with #12-24 threaded mounting holes, it is recommended to use Panduit part number **S1224-C** during this step when attaching the mounting ears.

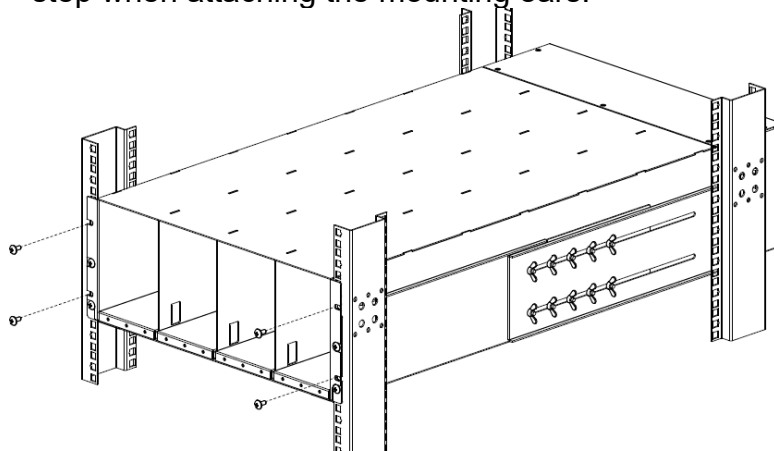

Figure 52: Secure the Mounting Brackets to the Rack

- Reinstall battery cartridges:
 - Refer to the handling instruction and reinsert all four battery cartridges into the EBP (see figure below).

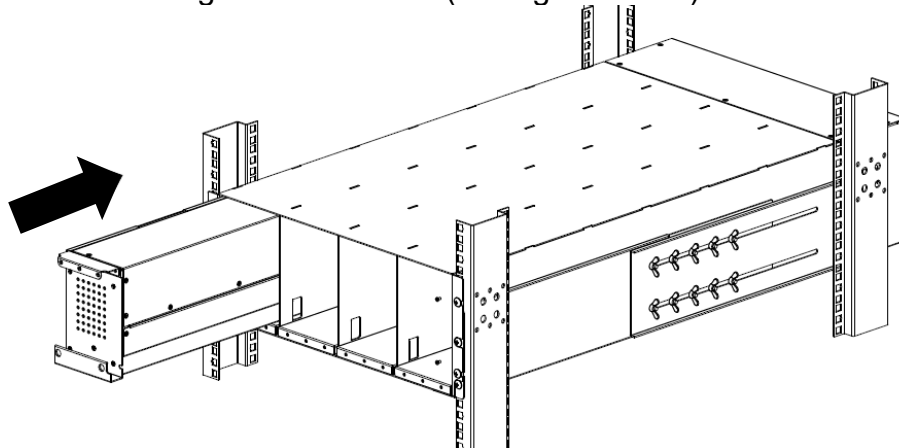

Figure 53: Reinsert the Battery Cartridges into the EBP

- Install and secure the battery baffle with the 8x screws (see figure below).

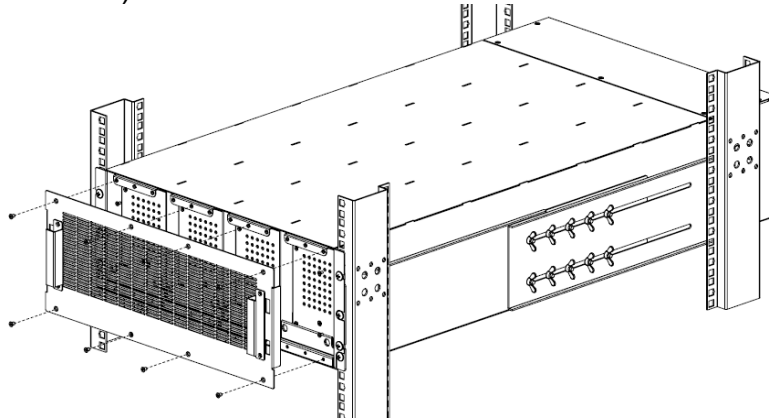

Figure 54: Reinstall the EBP Battery Baffle

- Reinstall the faceplate on the EBP, by aligning the front panel latches with the holes in the front of the unit and snapping the faceplate onto the front of the EBP. Should have a positive snap of the latches on the faceplate.

Two-Post Racks

Additional hardware is required for installation in a standard EIA two-post rack with threaded mounting holes.

An SRM19CM3 rack mount shelf would need to be used for this mounting technique. Please refer to the [Panduit Rack Mount Shelves specification](#) on the Panduit website for the specifications on this shelf to be used with each unit.

CAUTION



- *The units are heavy. Removing the units from its carton requires a minimum of two people.*
- *The 3-phase EBP (UVP480) cannot be mounted in a two-post rack, there is no shelf to support the weight of this unit. The weight of this unit would also make the two-post rack unstable.*
- *When installing optional EBP(s), make sure to install the EBP(s) directly below the UPS so that all wiring between the units can use the wiring provided with the units.*
- *The unit is not secured to the rack with this mounting technique, the unit is just set on top of the shelf.*

Note: Mounting shelves are required for each unit to avoid exceeding the shelf's capacity.

The Panduit two-post rack UPS/EBP mounting bracket (**U2PTRMT**) kit is also available. Please visit Panduit.com for more information and to check system compatibility.

Tower Mounting

The tower mounting is not the recommended mounting technique for the UPS, EBP, and MBS units. However, the mounting hardware for this technique is provided with most units. The 3-Phase UPS, EBP, and MBS units should not use this mounting technique due to physical configuration and physical weight of the unit.

CAUTION



- *The unit is heavy. Removing the unit from its carton requires a minimum of two people.*
- *If installing optional EBP(s), make sure to install the EBP(s) directly next to the UPS so that all wiring between the units can use the wiring provided with the units.*

Note: Tower mounting stands are required for each individual unit.

Tower mounting 2U Units (U01N11L, U01N11V, U01S11L, U01S11V, U01N12L, U01N12V, U01S12L, U01S12V, U01N13V, U01S13V, U01N14L, U01S14L, U01N16L-N, U01N18L-N, U02N11L, U02N11V, U02S11L, U02S11V, U02N12L, U02N12V, U02S12L, U02S12V, U02N14L, U02S14L, U02N16L-N, U02N18L-N, U03N11L, U03N11V, U03S11L, U03S11V, U03N12L, U03N12V, U03S12L, U03S12V, U03N14L, U03S14L, U03N15L, U03S15L, U03N16L-N, U03N18L-N, U05N11L, U05S11L, U06N11L, U06S11L, U10N11L, U10S11L, U05N12L, U05S12L, U06N12L, U06S12L, U10N12L, U10S12L, UVP024, UVP036, UVP048, UVP072, UVPL12H, UVPL50H)

Assemble the tower kit:

- Align to interlock two tower feet at a right angle and rotate to snap together (see figure below).

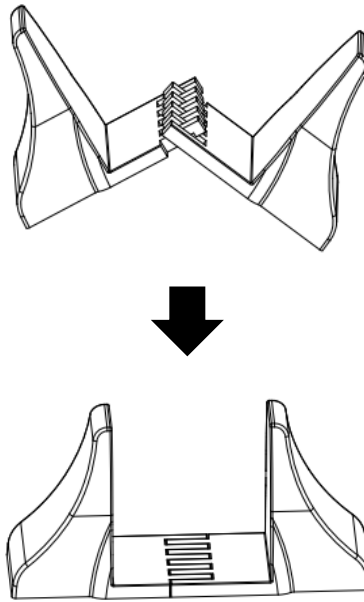

Figure 55a: Tower Kit for 2U Units

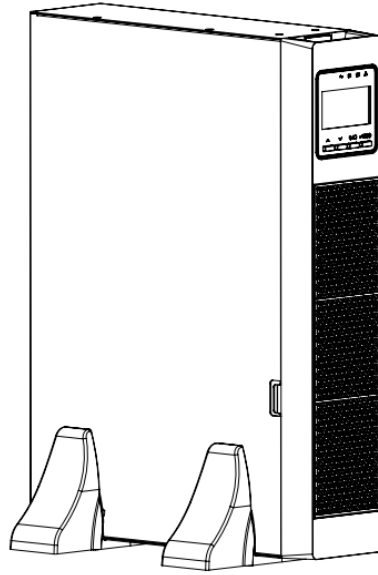

Figure 55b: 2U Unit using Tower Kit (Single Phase UPS example shown.)

For 2U Units with an internal battery cartridge (U01N11L, U01N11V, U01S11L, U01S11V, U01N12L, U01N12V, U01S12L, U01S12V, U01N13V, U01S13V, U01N14L, U01S14L, U02N11L, U02N11V, U02S11L, U02S11V, U02N12L, U02N12V, U02S12L, U02S12V, U02N14L, U02S14L, U03N11L, U03N11V, U03S11L, U03S11V, U03N12L, U03N12V, U03S12L, U03S12V, U03N14L, U03S14L, U03N15L, U03S15L):

- Remove the faceplate:
- Press both sides of UPS faceplate until the latches release (see figure below).

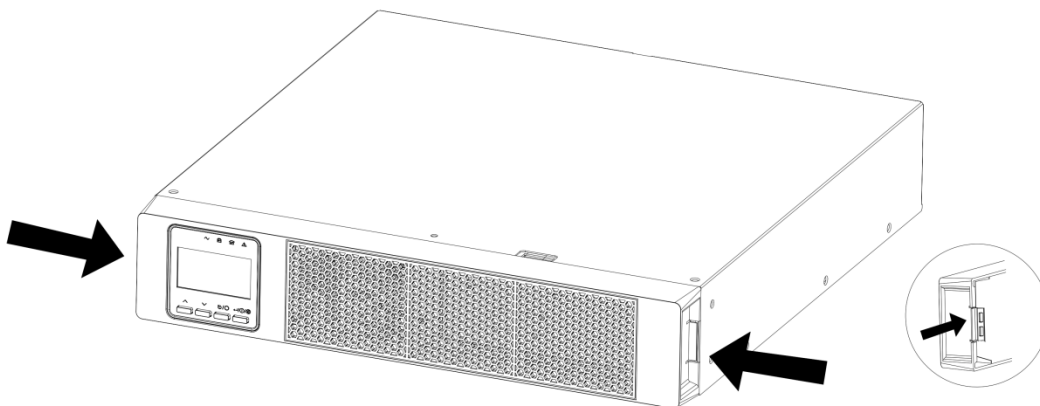

Figure 56: Press the Latches to Remove Faceplate

- Remove the faceplate (see figure below).

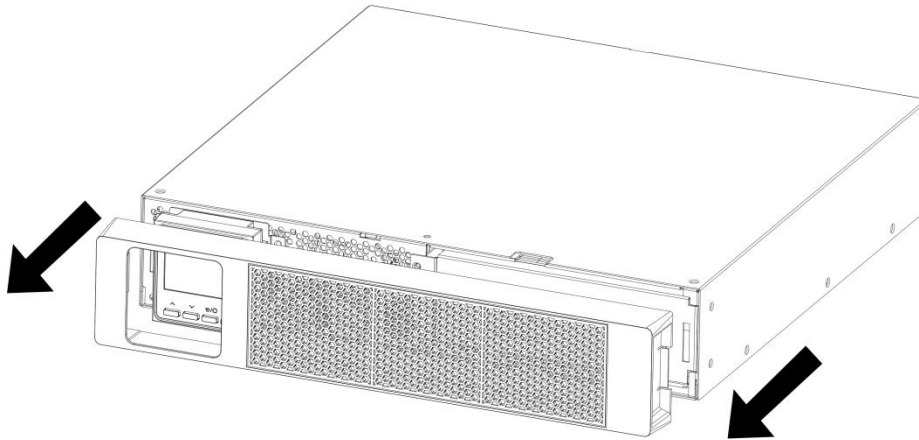

Figure 57: Remove the Faceplate

- Connect the internal battery cartridge:
- Connect the internal battery cartridge connector (see figure below). Press the connector tightly together to ensure a proper connection.

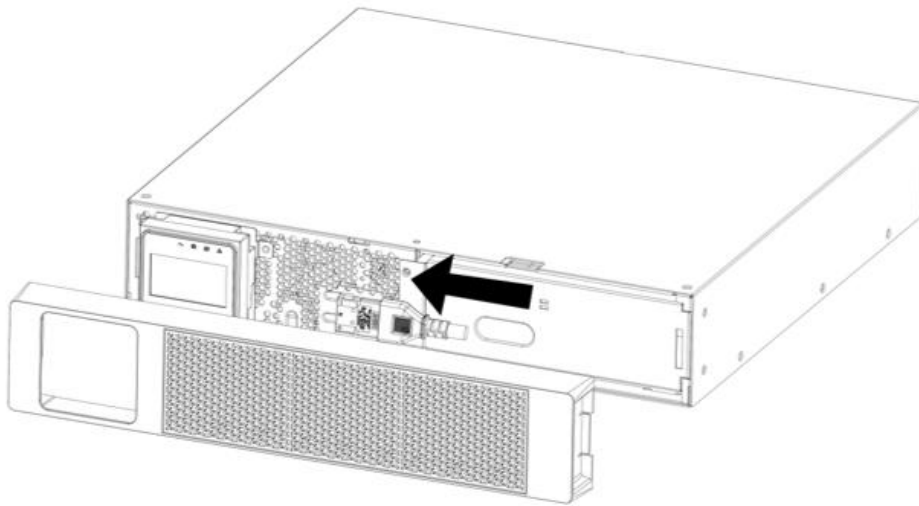

Figure 58: Connect the Internal Battery Cartridge Connector

CAUTION



A small amount of arcing may occur when connecting the internal battery cartridge. This is normal and will not harm personnel. Connect the cables quickly and firmly.

- Before the installation of the UPS faceplate, place the unit into the tower kit and manually rotate the LCD panel to the vertical position (see figure below). The screen may be manually rotated ¼ turn for rack or tower mounting. The EBP Battery Pack signage does not rotate.

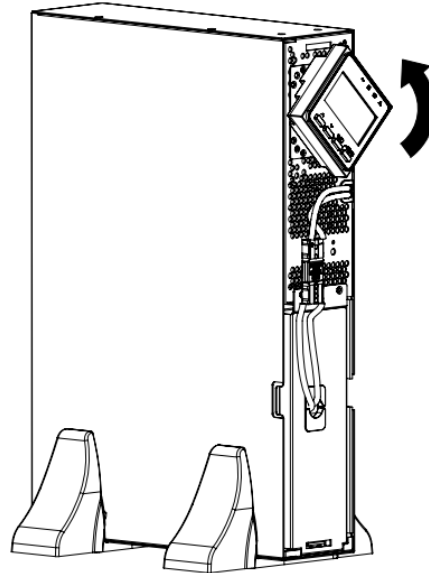

Figure 59: Manually Rotate the Display on 1-3kVA UPS Units

Note: The 2RU 5-10kVA Lithium UPS units have a touch display that can be configured electronically for Horizontal or Vertical orientation via menu options.

Note: The 2RU 5-10kVA Lithium UPS containing firmware V011 or earlier requires the LCD placement to be at the bottom position for this orientation to be correct. If the LCD position is desired at the top, the plastic bracket containing the display may be removed via four screws and rotated 180 degrees and reattached.

- Reinstall the faceplate on the UPS by aligning the front panel display through the hole in the faceplate and snapping the faceplate onto the front of the UPS. Should have a positive snap of the latches on the faceplate (see figure below).

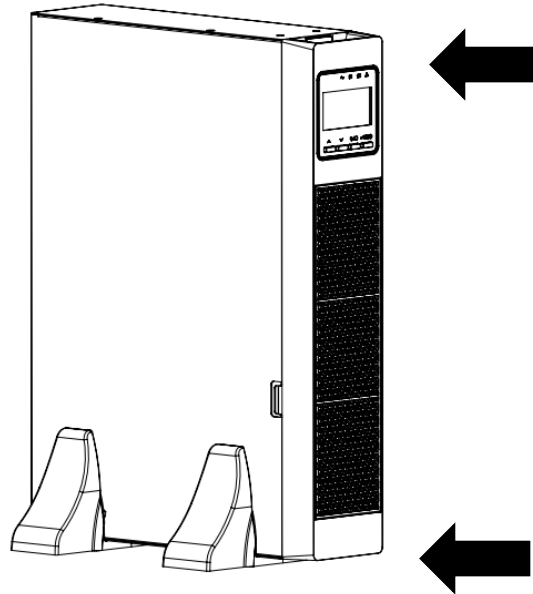

Figure 60: Example of Snapping the Faceplate onto the Front of the UPS

- Install the faceplate on the EBP by aligning the front panel latches with the holes in the front of the unit and snapping the faceplate onto the front of the EBP. Should have a positive snap of the latches on the faceplate.
- Connect the internal battery cartridges:
- Remove and retain the two screws on top and bottom each battery cover near the center of the unit, slide the battery cover toward the center, then remove and retain (see figure below).

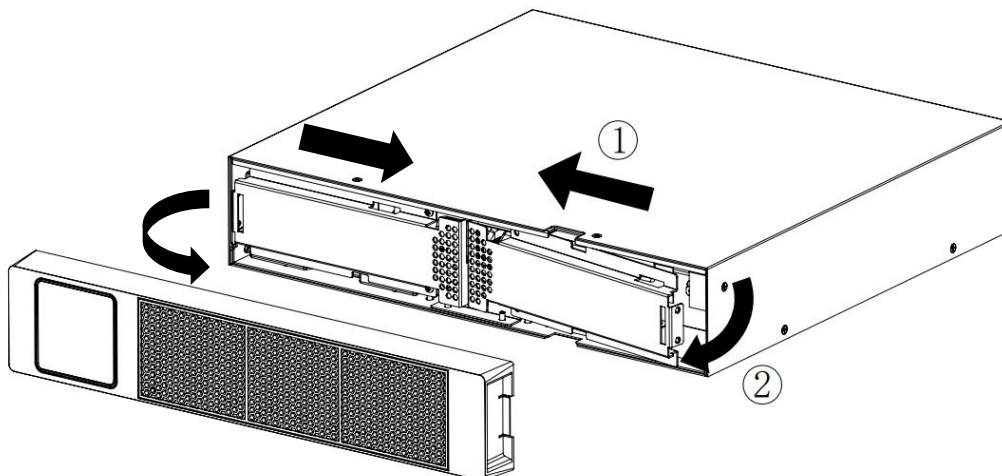

Figure 61: Remove the Faceplate

- Pull both battery cartridge connectors through the middle hole in the chassis, connect a battery cartridge to each connector (see figure below). Press the connector tightly together to ensure a proper connection. Connect the other battery cartridge in the EBP. Both internal battery cartridges should be connected. Press each connector tightly together to ensure a proper connection.

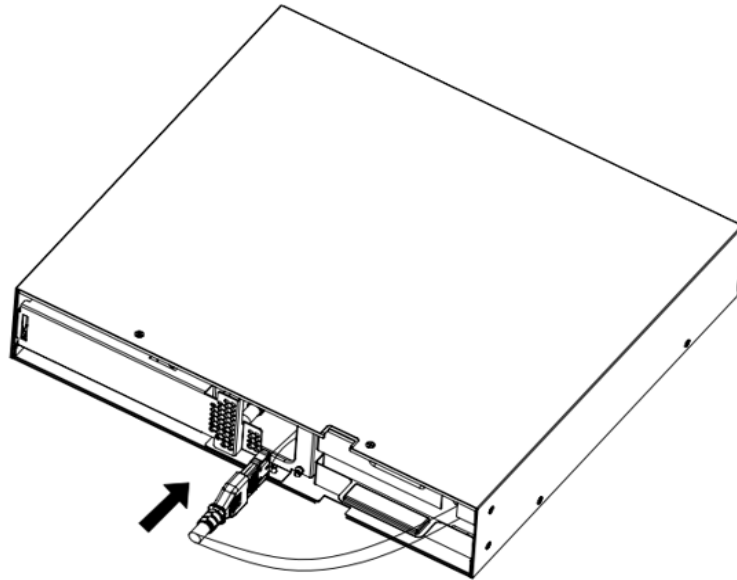

Figure 62: Connect the First Internal Battery Cartridge Connector

- Insert the connectors back into the middle hole on the chassis.
- Reinstall and secure the retained battery covers in reverse order of above step.
- Place the unit into its own tower kit to the right of the UPS. The EBP Battery Pack signage does not rotate.
- Reinstall the faceplate on the EBP, by aligning the front panel latches with the holes in the front of the unit and snapping the faceplate onto the front of the EBP unit. Should have a positive snap of the latches on the faceplate.

Tower mounting 3U Units (U05N11V, U05S11V, U06N11V, U06S11V, U06N12V, U06S12V, U10N11V, U10S11V, U10N12V, U10S12V, UVP240)

- Assemble the tower kit with one extender for each set of tower feet:
- Align to interlock a tower foot and one extender at a right angle and rotate to snap together.
- Then align to interlock the tower foot with the extender to the second tower foot at a right angle and rotate to snap together (see figure below).

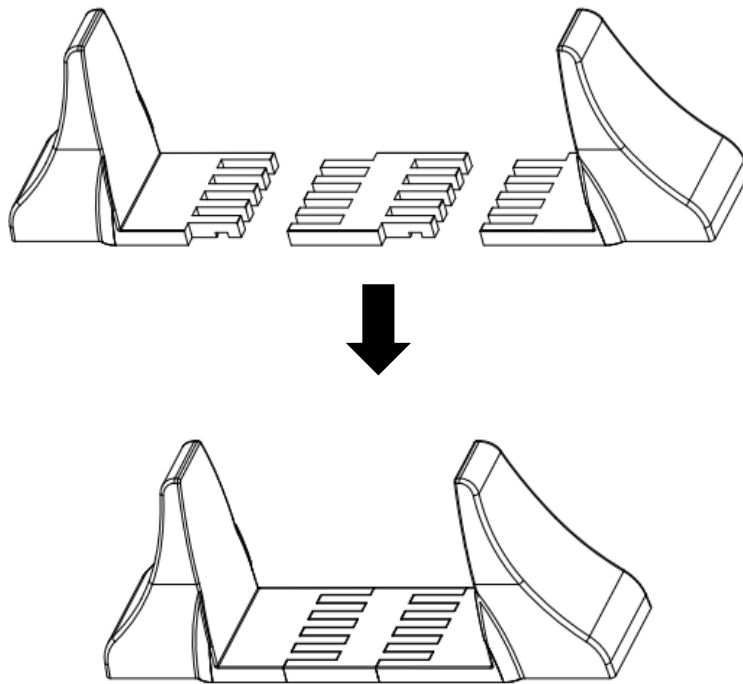

Figure 63: Tower Kit for 3U Units

- Place the UPS in the tower kit, the UPS LCD does not physically rotate, it will rotate electronically (see 5-20kVA User Manual for details).
- Install the faceplate on the UPS unit, by aligning the front panel latches with the holes in the front of the unit and snapping the faceplate onto the front of the unit. Should have a positive snap of the latches on the faceplate (see figure below).

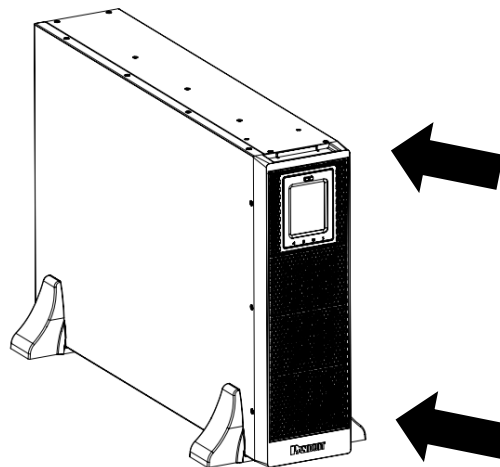

Figure 64: Example of Snapping the Faceplate onto the Front of the UPS

- Before placing the faceplate on the EBP unit, connect the Battery Cartridge connectors (see figure below). Press each (4) connector tightly together to ensure a proper connection.
- The larger battery cartridges connect to connectors 1 and 3, each half of the smaller battery cartridge connect to connectors 2 and 4.

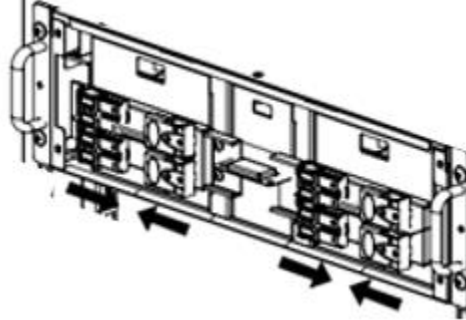

Figure 65: Tower Kit for 3U Units

- Place the EBP unit into its own tower kit to the right of the UPS. The EBP signage does not rotate.
- Install the faceplate on the EBP unit by aligning the front panel latches with the holes in the front of the unit and snapping the faceplate onto the front of the unit. Should have a positive snap of the latches on the faceplate.

Tower mounting 3-Phase Units (U10N32V, U10S32V, U15N32V, U15S32V, U20N32V, U20S32V, UMB20K)

Important: the UVP480 EBP cannot be tower mounted due to physical constraints. Since this External Battery Pack unit is for all 3-phase UPS units, it is not recommended to tower mount any 3-phase units.

Section 4 – Electrical Connections

The UPS, EBP, and MBS units each have unique electrical connections. Refer to whichever section below matches the UPS system that is being deployed. For safety reasons, all UPS units require an external circuit breaker on each AC supply input.

1-10kVA Single-Phase UPS and Associated EBP (U01N11L, U01N11V, U01S11L, U01S11V, U01N12L, U01N12V, U01S12L, U01S12V, U01N13V, U01S13V, U01N14L, U01S14L, U01N16L-N, U01N18L-N, U02N11L, U02N11V, U02S11L, U02S11V, U02N12L, U02N12V, U02S12L, U02S12V, U02N14L, U02S14L, U02N16L-N, U02N18L-N, U03N11L, U03N11V, U03S11L, U03S11V, U03N12L, U03N12V, U03S12L, U03S12V, U03N14L, U03S14L, U03N15L, U03S15L, U03N16L-N, U03N18L-N, U05N11V, U05S11V, U06N11V, U06S11V, U06N12V, U06S12V, U10N11V, U10S11V, U10N12V, U10S12V, U05N11L, U05S11L, U06N11L, U06S11L, U10N11L, U10S11L, U05N12L, U05S12L, U06N12L, U06S12L, U10N12L, U10S12L, UVP024, UVP036, UVP048, UVP072, UVP240, UVPL12H, UVPL50H)

- This section is for single system connections. The Single-Phase 5-10kVA Lithium UPS units may also be connected in a parallel configuration. If using a parallel configuration, refer to section **5-10kVA Lithium UPS Parallel Mode System Configuration** below for more connection details.
- Connect the UPS to the input source. The Single-Phase UPS units will either have an input power cord with a plug or input hardwire connections. Refer to the appropriate User Manual for more information.
- The 1-5kVA UPS units (refer to SKU listed below) have an input power cord with a plug that interfaces with the region’s standard outlets (U01N11L, U01N11V, U01S11L, U01S11V, U01N12L, U01N12V, U01S12L, U01S12V, U01N13V, U01S13V, U01N14L, U01S14L, U01N16L-N, U01N18L-N, U02N11L, U02N11V, U02S11L, U02S11V, U02N12L, U02N12V, U02S12L, U02S12V, U02N14L, U02S14L, U02N16L-N, U02N18L-N, U03N11L, U03N11V, U03S11L, U03S11V, U03N12L, U03N12V, U03S12L, U03S12V, U03N14L, U03S14L, U03N15L, U03S15L, U03N16L-N, U03N18L-N, U05N11V, U05S11V, U05N11L, U05S11L).
- Properly insert the plug into the region’s standard outlet. It is assumed that the standard outlet is wired and protected with the appropriate breakers per the local standard electrical code(s) by a qualified Electrician.
Note: Each part of the system must maintain a connected earth ground. The outlet must contain the appropriate ground.
- Certain 5-10kVA UPS units (refer to SKU listed below) have a hardwire input terminal (U06N11V, U06S11V, U06N12V, U06S12V, U10N11V, U10S11V, U10N12V, U10S12V, U06N11L, U06S11L, U10N11L, U10S11L, U05N12L, U05S12L, U06N12L, U06S12L, U10N12L, U10S12L).
- The wired connections must be appropriately sized and protected.

- EU 5kVA Lithium units (U05N11L, U05S11L) must have a minimum of 30A double pole circuit breaker and at least a three-wire cable (L1, L2, Ground) with 2.5mm² wires, per IEC60950.
- NA 6kVA units (U06N11V, U06S11V, U06N11L, U06S11L) must have a minimum of 35A double pole circuit breaker and at least a three-wire cable (L1, L2, Ground) with 10AWG 75°C copper wires, per the National Electric Code (NEC).
- EU 6kVA units (U06N12V, U06S12V, U06N12L, U06S12L) must have a minimum of 32A single pole breaker and at least a three-wire cable (L, N, Ground) with 4mm² wires, per IEC60950.
- NA 10kVA units (U10N11V, U10S11V, U10N11L, U10S11L) must have a minimum of 60A double pole circuit breaker and at least a three-wire cable (L1, L2, Ground) with 6AWG 75°C copper wires, per the NEC.
- EU 10kVA units (U10N12V, U10S12V, U10N12L, U10S12L) must have a minimum of 63A single pole breaker and at least a three-wire cable (L, N, Ground) with 10mm² wires, per IEC60950.
- The cable must conform to the local wiring codes according to environmental conditions (temperature and natural conditions).
- Each part of the system must maintain a connected earth ground.
- Before hardwiring the UPS unit, ensure that there is no power on the wires. Use lock-out tag-out at the breaker panel / local disconnect.
- Remove the small protective cover on the terminal block housing on the back of the UPS.
- Feed the input cable through a provided cable gland and terminal block housing.
Note: Ensure that the cable gland is separated on each side of the terminal block house to allow for the cable to be secured to the housing.
- Crimp a ring terminal where required (U06N11V, U06S11V, U10N11V, U10S11V, U06N12V, U06S12V, U10N12V, U10S12V) onto each wire with a standard crimping tool for the wire size.
- Connect each wire under the appropriate screw as indicated on the back of the UPS.
Note: Each part of the system must maintain a connected earth ground.
- After completing the wiring, confirm again that all wiring is correct.
- Tighten the cable gland to the terminal block housing to secure the cable to the UPS.
- Leave the terminal block cover off the housing for the next step of connecting the load(s).
- Connect the load(s) to the UPS. These UPS units will either have output outlets or output outlets and output hardwire connections.
- The 1-5kVA UPS units (refer to SKU) have regional standard outlets (U01N11L, U01N11V, U01S11L, U01S11V, U01N12L, U01N12V, U01S12L, U01S12V, U01N13V, U01S13V, U01N14L, U01S14L, U01N16L-N, U01N18L-N, U02N11L, U02N11V, U02S11L, U02S11V, U02N12L, U02N12V, U02S12L, U02S12V, U02N14L, U02S14L, U02N16L-N,

U02N18L-N, U03N11L, U03N11V, U03S11L, U03S11V, U03N12L, U03N12V, U03S12L, U03S12V, U03N14L, U03S14L, U03N15L, U03S15L, U03N16L-N, U03N18L-N, U05N11V, U05S11V, U05N11L, U05S11L).

- Properly insert the plugs from the loads into the standard outlets.
- Outlet Group 2 and (optionally) Group 3 may be used for critical or noncritical loads, depending on how the UPS system is configured. Group 1 should always be used for critical loads only.
- Each part of the system must maintain a connected earth ground. Only use standard power cords with a ground conductor and standard loads with a connection to ground through the power cord.
- The 5-10kVA UPS units (refer to SKU) have regional standard outlets and a hardwire connection (U06N11V, U06S11V, U06N12V, U06S12V, U10N11V, U10S11V, U10N12V, U10S12V, U05N12L, U05S12L, U06N11L, U06S11L, U06N12L, U06S12L, U10N11L, U10S11L, U10N12L, U10S12L).
- For units with standard outlets and a hardwire output, make the hardwire connection first.
- The wire used for all three conductors must be as specified:
- NA 6kVA units (U06N11V, U06S11V, U06N11L, U06S11L) must have at least a three-wire cable (L1, L2, Ground) with 10AWG 75°C copper wires, per the NEC.
- EU 6kVA units (U06N12V, U06S12V, U06N12L, U06S12L) must have at least a three-wire cable (L, N, Ground) with 4mm² wires, per IEC60950.
- The cable must conform to the local wiring code according to environmental conditions (temperature and natural conditions).
- Each part of the system must maintain a connected earth ground, including the load.
- Before hardwiring the UPS load, ensure that there is no power on the terminals.
- The small protective cover on the terminal block should already be removed from the last step.
- Feed the output cable through a provided cable gland and terminal block housing.

Note: Ensure that the cable gland is separated on each side of the terminal block house to allow for the cable to be secured to the housing.
- Crimp a ring terminal where required (U06N11V, U06S11V, U10N11V, U10S11V, U06N12V, U06S12V, U10N12V, U10S12V) onto each wire with a standard crimping tool for appropriately sized wire.
- Connect each wire under the appropriate screw as indicated on the back of the UPS.

Note: Each part of the system must maintain a connected earth ground.
- After completing the wiring, confirm again that all wiring is correct.
- Tighten the cable gland to the terminal block housing to secure the cable to the UPS.
- Replace the terminal block cover on the housing of the UPS.

- Then properly insert the plugs from the loads into the standard outlets.
(**Note:** Outlet Groups 2 and optional Outlet Group 3 may be used for critical or noncritical loads, depending on how the UPS system is configured. Group 1 is the hardwire output and is always used for critical loads only).
Note: Each part of the system must maintain a connected earth ground.
- Connect the EBP(s) to the UPS. The UPS units may have 0 to 8 EBP units connected to extend the battery run time of the UPS system. Refer to SKU information below for limitations.
- As indicated in the mounting section, the EBP should be mounted under or near the UPS.
For setups with a separate EBP cabinet, Panduit extended EBP cables (5m) are available as optional accessories. (*UVP1T3VCBL*, *UVP5T10VCBL*, *UVP10T20VCBL*, *UVPL12HCBL*)
- Some UPS units are compatible with specific EBP units and only allow a maximum number of compatible EBP units to be connected in the UPS system. Refer to the table below:

Model SKU	Compatible EBP	Maximum Supported Number of EBPs per Unit.	Optional Extended EBP Cable (5m) Accessory SKU
U01N11L, U01S11L, U01N12L, U01S12L, U01N14L, U01S14L, U02N11L, U02S11L, U02N12L, U02S12L, U02N14L, U02S14L, U03N11L, U03S11L, U03N12L, U03S12L, U03N14L, U03S14L, U03N15L, U03S15L	N/A	0	N/A
U01N11V, U01S11V, U01N12V, U01S12V	UVP036	4	UVP1T3VCBL
U01N13V, U01S13V	UVP024	4	UVP1T3VCBL
U02N11V, U02S11V, U02N12V, U02S12V	UVP048	4	UVP1T3VCBL
U03N11V, U03S11V, U03N12V, U03S12V	UVP072	4	UVP1T3VCBL

Model SKU	Compatible EBP	Maximum Supported Number of EBPs per Unit.	Optional Extended EBP Cable (5m) Accessory SKU
U01N16L-N, U01N18L-N, U02N16L-N, U02N18L-N, U03N16L-N, U03N18L-N	UVPL50H	8	UVP1T3VCL
U05N11V, U05SIIV, U06N11V, U06S11V, U06N12V, U06S12V, U10N11V, U10S11V, U10N12V, U10S12V	UVP240	5	UVP5T10VCBL
U05N11L, U05S11L, U05N12L, U05S12L, U06N11L, U06S11L, U06N12L, U06S12L, U10N11L, U10S11L, U10N12L, U10S12L	UVPL12H	8 [†]	UVP10T20VCBL

[†] 5-10kVA Lithium units support up to 8 UVPL12H batteries only with **V021 FW** or later. Earlier versions support up to 4.

Note: Before connecting the EBP to the UPS system with the battery cable, first connect an appropriately sized ground wire from the ground screw on the back of the last chassis in the system to a ground screw on the back of the EBP unit being connected. The appropriate ground wire is provided with the 1-3kVA EBP units. The ground wire is not provided with the 5-10kVA EBP units.

Note: Refer to [Appendix M](#) for the ground screw location, ground wire size, and suggested grounding examples.

- Plug the EBP battery cables fully into the battery connector(s). This may require some force to be securely engaged. Either connector on the back of the EBP may be used except in cases where the connections are color-matched (UVPL12H). The Figure below is an example of an EU 1kVA 36V VRLA UPS system. The actual UPS and EBPs that are part of the system deployed may have battery connections in different physical locations on the back of the UPS unit and/or EBP units from that shown in this figure. Refer to the appropriate UPS User Manual for the location of the battery

connector(s) on the back of the UPS and EBP units. Insert and press the connector tightly together to ensure a proper connection. You should get a positive click when fully inserted.

Note: The unused connector on the last EBP unit must retain the battery connector cover plate for safety. This port has a battery voltage on it.

- Verify that the EBP connections are tight, and the adequate bend radius and strain relief exist for each cable.

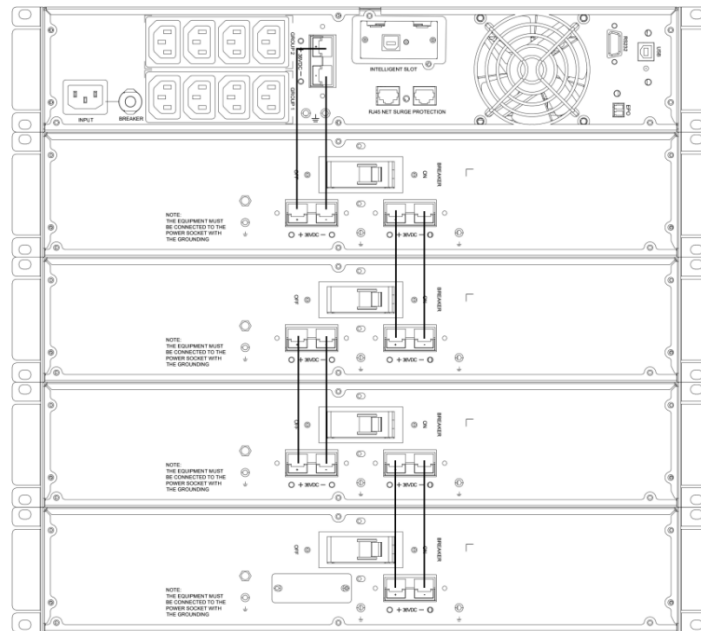

Figure 66: Connect the EBP(s) - Example 4x VRLA EBP System

- For **5-10kVA VRLA UPS (UVP240)** units, there is an additional battery temperature communication cable. Connect this cable to the ports labeled **BAT_T** on the rear panel of the EBP and UPS.
- For **1-3kVA Long Runtime Lithium UPS units** (U01N16L-N, U01N18L-N, U02N16L-N, U02N18L-N, U03N16L-N, U03N18L-N) and **5-10kVA Lithium UPS units** (U05N11L, U05S11L, U05N12L, U05S12L, U06N11L, U06S11L, U06N12L, U06S12L, U10N11L, U10S11L, U10N12L, U10S12L) additional cables and steps are required for connection with their respective EBP (1-3kVA EBP: UVPL50H; 5-10kVA EBP: UVPL12H).
- For 1-3kVA Long Runtime Lithium UPS models, reference Figure 67b
- For 5-10kVA Lithium UPS models, reference Figure 67a.
- Connect the RJ45 cable from the EBP COM port on the UPS to one of the COM ports on the EBP.
- If using multiple Lithium EBPs, connect an additional RJ45 cable between the COM ports on each EBP.
- If using multiple Lithium EBPs, connect an RJ45 cable between an open

CAN port on each EBP.

- Set the addressable (ADD) DIP toggle switches on each EBP by sliding them up or down so that they are in the correct sequential order and different from one another. (Refer to Figure 67d below.)

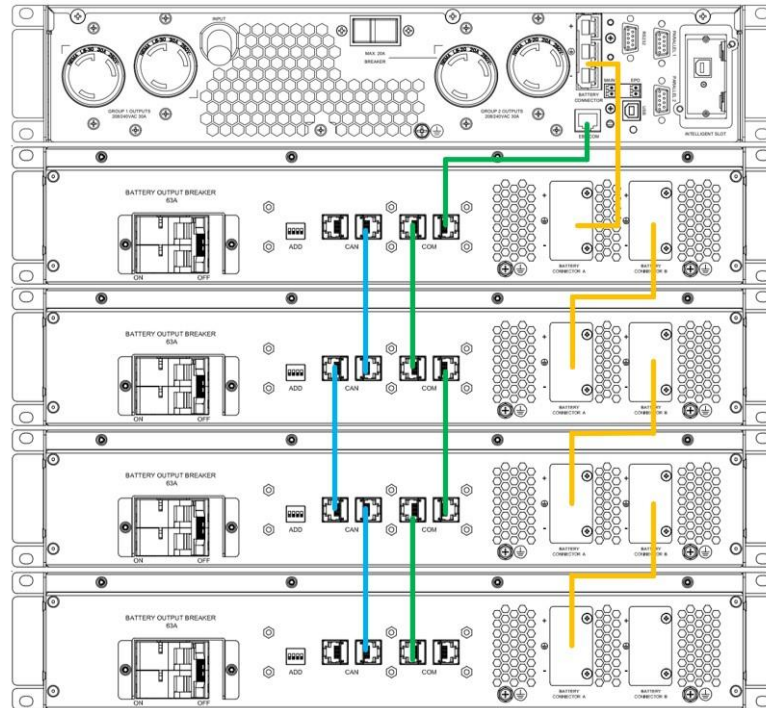

Figure 67a: Example 5kVA Lithium EBP System (4x UVPL12H EBPs shown)

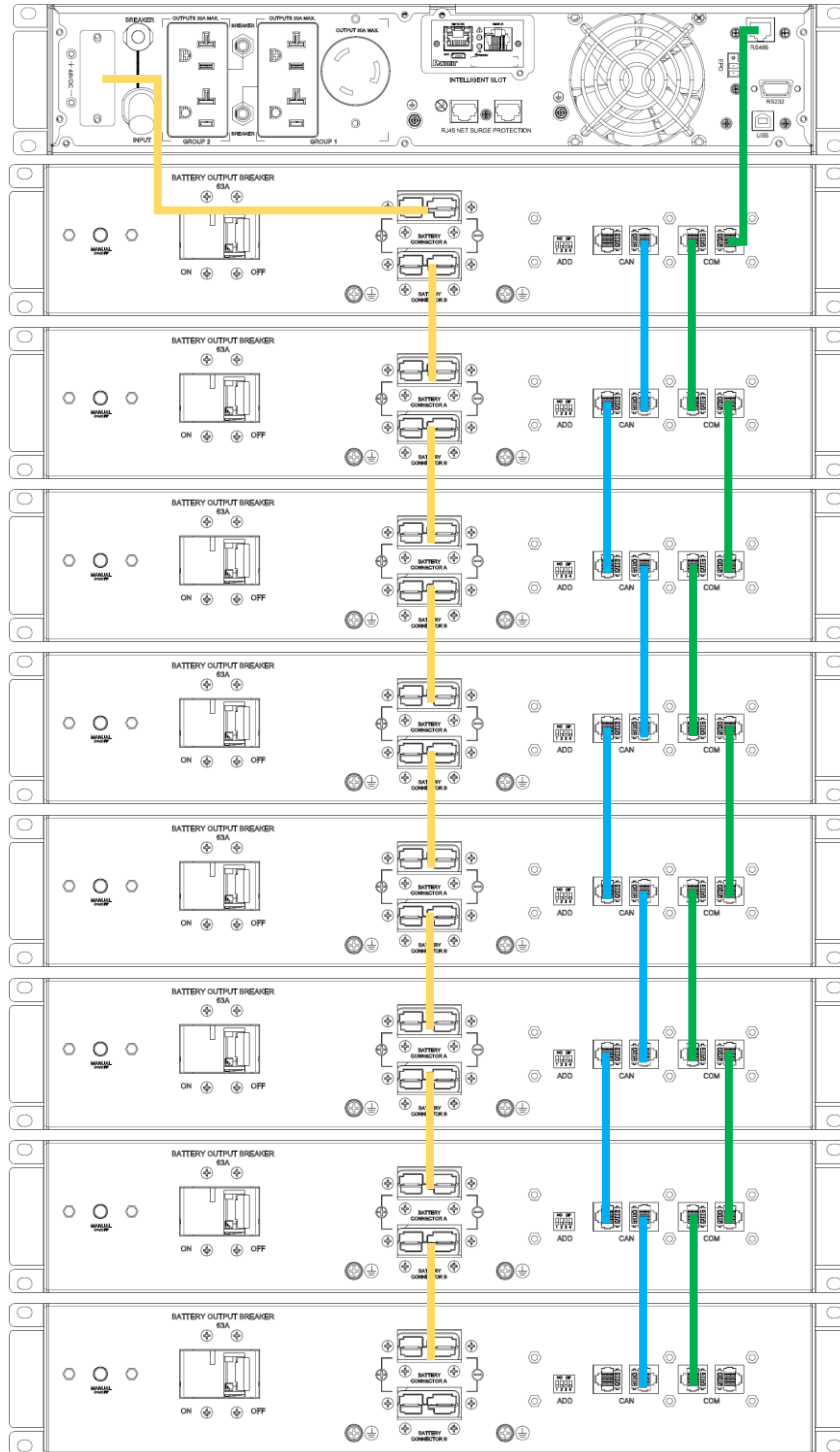

Figure 67b: Example 3kVA Lithium Long Runtime UPS EBP System (8x UVPL50H shown)

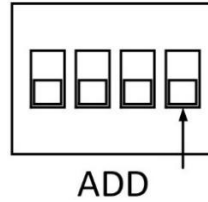

Figure 67c: UVPL12H Address DIP switch

EBP Number	DIP Address	Position (Left) 0 = Down 1 = Up	Position 0 = Down 1 = Up	Position 0 = Down 1 = Up	Position (Right) 0 = Down 1 = Up
1	“0”	0	0	0	0
2	“1”	0	0	0	1
3	“2”	0	0	1	0
4	“3”	0	0	1	1
5	“4”	0	1	0	0
6	“5”	0	1	0	1
7	“6”	0	1	1	0
8	“7”	0	1	1	1

Figure 67d: Lithium EBP DIP Address Reference Table

- Power up the system:
- After all electrical connections have been made the system may be powered up.
- Ensure all breakers in the system are turned on. The breakers may contain text denoting which position is ON/OFF.
- Power ON all breakers on the back of each EBP in the system.
Note: The UVP240 EBP units have two breakers on the back of each unit. Both breakers must be powered ON for the EBP to function in the system. All other EBP units have a single breaker at the back of the unit. This breaker must be powered on for the EBP to function in the system.
- For **UVPL50H**, turn the EBP on by pushing the “Manual ON/OFF” button next to the circuit breaker for five seconds. Repeat this for each EBP *after* the circuit breaker is powered ON.
- Power ON all UPS output breakers. Refer to the appropriate UPS User Manual for the location of the input breaker on each UPS unit.
- Power ON all UPS input breakers. Refer to the appropriate UPS User Manual for the location of the input breaker on each UPS unit.
- For the 1-5kVA units with an input plug, the system may start powering up immediately if the outlet that the UPS is plugged into has power.
- For hardwired UPS systems and systems without a live input outlet, remove the lock out tag out from the breaker panel and turn ON the panel breaker(s) for the UPS system.
- The system should start to power up. Refer to the appropriate Panduit UPS User Manual to properly configure the system for use.

- Suggested options for 5-10kVA UPS configuration upon initial installation: These are the minimum options that should be configured after initial power up of the system. Other options could be configured later. However, if the system being powered up is a parallel system (Single-Phase 5-10kVA Lithium UPS models only), then the parallel configurations must also be configured at initial power up.

5-10kVA UPS Initial Configuration Settings				
Display Menu Path	Parameters	Default Value	Options	Description
Setup/ Basic	Language	English	English, Simplified Chinese	Select the language required for the UPS Display Interface. Language options vary by model and firmware version.
	Password	123456	6 digits	The password must be 6 characters, numbers only. For security, this password should be changed after initial power up.
	Date & Time	2022-01-01 & 07:00:00	YYYY-MM-DD, HH:MM:SS	Enter the current date and time (Note: time is 24-hour format).
Setup/ Advanced	Output Setup	Depends on SKU (NA = 208V, EU = 230V)	Depends on SKU	Set the output voltage for the UPS. This setting can only be changed when the UPS output is off.
	Battery Install Date	UPS Manuf. Date	YY-MM-DD	This setting will set the start date to determine when the battery notification and alarm will activate in the future. It is suggested to change this to the date of installation to better monitor battery replacement timing. Changing this date may also clear any pop-ups or warnings related to battery maintenance upon initial installation. Note: Battery Installation date is a system level setting. Setting unique battery installation dates for multiple batteries is not supported.
	No Battery Warning	Disabled	Enable / Disable	This setting allows the UPS to display the No Battery alert on the LCD as well as emit an audible alarm when there is no battery connection detected. It is recommended to set this to 'Enabled' to allow for easier detection of a battery disconnection issue after installation and for remote notification of this condition via the Web User Interface

Parallel Mode System Configuration for 5-10kVA Lithium UPS (U05N11L, U05S11L, U05N12L, U05S12L, U06N11L, U06S11L, U06N12L, U06S12L, U10N11L, U10S11L, U10N12L, U10S12L)

The 1-Phase 5-10kVA Lithium UPS may be configured as a Single Mode System or as a Parallel Mode System. This section provides the electrical connections for two or more UPS units in a Parallel Mode System with a Single-Phase input and a Single-Phase Output.

The following Figure shows the high-level power and control connection diagrams of the Parallel Mode UPS system. A Parallel Mode system allows two to four UPS units of the same SKU to be connected in parallel.

Note: The parallel mode allows the connected group of UPS units to behave as one large UPS system thereby increasing the maximum load capacity of the system.

SKU	Max. Load Capacity 2 units in parallel.	Max. Load Capacity 3 units in parallel.	Max. Load Capacity 4 units in parallel.
U05N11L / U05N12L	10 kVA	15 kVA	20 kVA
U06N11L / U06N12L	12 kVA	18 kVA	24 kVA
U10N11L / U10N12L	20 kVA	30 kVA	40 kVA

Note: Redundant units are not calculated in the overall capacity of the parallel system.

Note: There are critical restrictions for connecting these units in parallel.

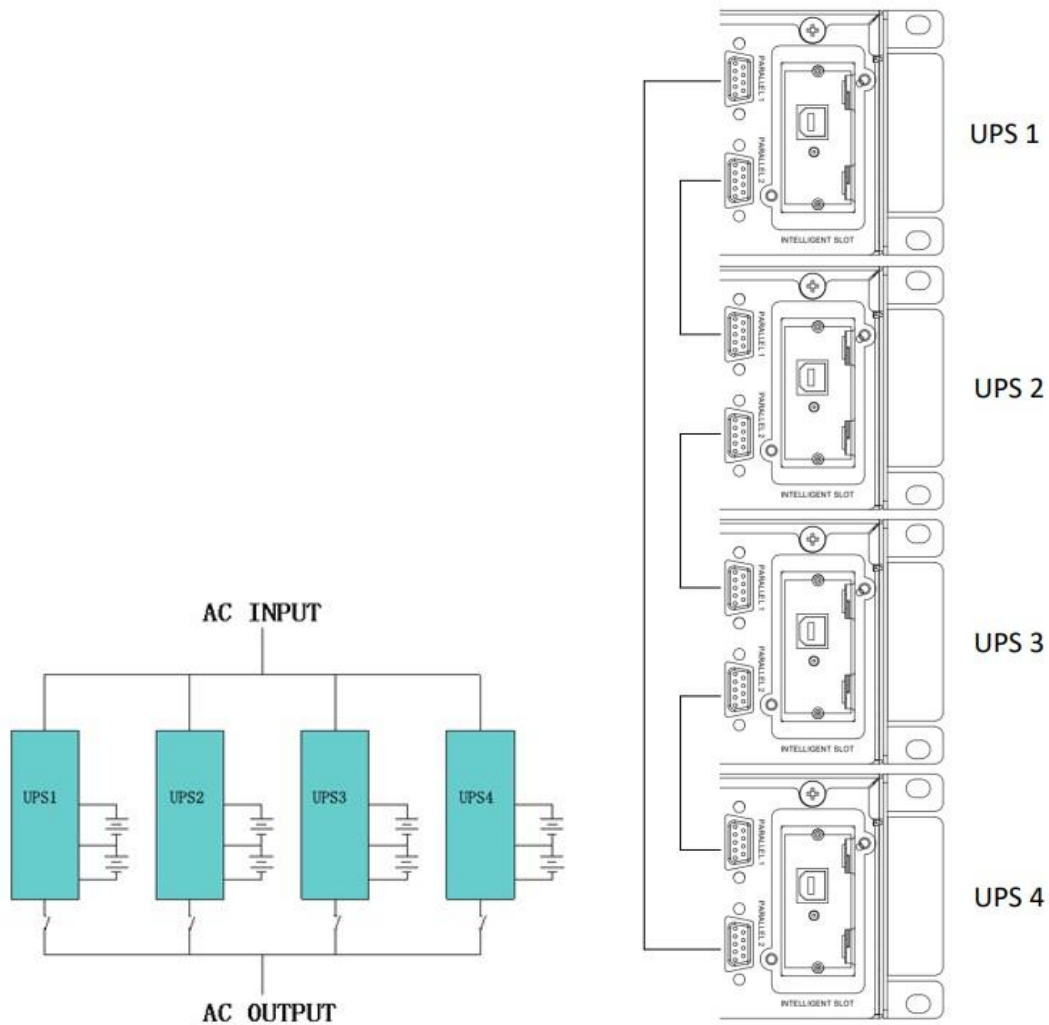

Figure 68a: Parallel System Power/Control Connections

To ensure that all UPS units in the system are equally utilized and comply with relevant wiring rules, follow the requirements below:

- All UPS units in the system must be the same SKU.
- All UPS units in the system must be connected to the same Input Mains source.
- All UPS units in the system must be connected to a common output bus.
- The length and specification of all UPS power cables (mains input, bypass input, and the output cables) must be the same type and same length. This helps to facilitate load sharing between the UPS units when operating in all working modes.
- The UPS units should be physically located near each other to minimize the load sharing effects due to environmental conditions.
- A maximum of 4 units may be connected in parallel.

Parallel Mode Wiring for 5-10kVA Lithium UPS (U05N11L, U05S11L, U05N12L, U05S12L, U06N11L, U06S11L, U06N12L, U06S12L, U10N11L, U10S11L, U10N12L, U10S12L)

Follow the power and control wiring as indicated in the figure above.

1. Connect the UPS Parallel System to the input source:
 - a. Before wiring together, make sure each UPS input is OFF and there is no output from any UPS unit.
 - b. Connect the Mains inputs of all UPS units in the parallel system to a common source with the same cable type and cable length (refer to the 5-20kVA User manual for terminal block labels). **Note:** Each part of the system (input, battery, and load) must maintain a connected earth ground.
 - c. With the above restriction on the input cables, follow the steps shown in the **1-10kVA Single-Phase UPS and Associated EBP** section for wiring each UPS input in the Parallel Mode System.
2. Connect the EBP(s) to the UPS:
 - a. Follow the steps shown in the **1-10kVA Single-Phase UPS and Associated EBP** section for wiring each EBP unit to each UPS in the Parallel Mode System.
3. Connect the Parallel System Control (refer to the **Figure 68** above):
 - a. Connect the shielded and double insulated DB9 control cables (one provided with each 5-10kVA Lithium UPS unit) in a ring configuration between UPS units in the parallel system as shown in the Figure. The ring configuration ensures high reliability of the control.
4. Parallel Mode Setup and Startup:
 - a. Each UPS unit in the Parallel mode system must be properly configured before the Parallel mode system output is connected. Refer to the “Parallel Mode Setup and Startup” section in the **Panduit UPS 5-20kVA User Manual**.
5. Connect the UPS Parallel System to the common output bus:
 - a. Connect the outputs of each UPS unit in the parallel system through an external breaker to a common output bus with the same breaker type, same cable type, and same cable length. **Note:** Each part of the system (input, battery, and load) must maintain a connected earth ground.
 - b. Outputs of all units in the parallel system must be connected the same way – as a single-phase output.
 - c. With the above restriction on the output cables, follow the steps shown in the **1-10kVA Single-Phase UPS and Associated EBP** section for wiring each UPS output in the Parallel Mode System.
6. Power up the system:
 - a. After all electrical connections have been made and the parallel configuration has been completed, the system may be powered up.
 - Power ON all breakers on the back of each EBP in the system. **Note:** The Lithium EBP units have a single breaker on the back of the unit.
 - Remove the lock out tag out from the breaker panel and turn ON the panel breaker(s) for the UPS system.

- The system should start to power up. Refer to the **Panduit 5-20kVA UPS User Manual** to properly configure the system for use.

10-20kVA 3-Phase UPS and Associated EBP (U10N32V, U10S32V, U15N32V, U15S32V, U20N32V, U20S32V, UVP480)

The 3-Phase systems may be configured as a Single Mode System or as a Parallel Mode System. In addition, the output may be connected to single-phase loads or to 3-Phase loads.

Single Mode System Configuration with 3-Phase or Single-Phase Output

All UPS units by default are configured as a single mode system. A single mode system is a single UPS connected to an AC power source and that UPS provides the AC power to the load.

This section provides the electrical connections for Single Mode UPS system with a 3-Phase input and optionally connected as a 3-Phase or a Single-Phase Output.

- When selecting, connecting, and routing power cables, follow local safety regulations and rules.
- If external conditions such as cable layout or ambient temperatures change, verify in accordance with the IEC-60364-5-52 or local regulations.

1. Connect the UPS to the input source.

a. All 3-phase UPS units (10-20kVA) have a hardwire input (U10N32V, U10S32V, U15N32V, U15S32V, U20N32V, U20S32V).

i. The wired connections must be appropriately sized and protected.

1. Refer to the table below for the properly rated breaker and wire size in the cable used.

a. If the rated voltage is 400 V, multiply the currents by 0.95. If the rated voltage is 415 V, multiply the currents by 0.92.

2. When the mains input and bypass input have the same input power source (known as single feed), configure both types of input power cables as mains input power cables. The cables listed in the table must adhere to the following requirements:

a. Routing mode: Routing the cables over the cable ladder or bracket in a single layer (IEC60364-5-52 middle E).

b. The maximum ambient temperature should be 30°C.

c. The AC voltage loss must be less than 3%, and the DC voltage loss must be less than 1%.

d. Must use 90°C rated or higher copper flexible cable.

e. The AC power cable length cannot exceed 30m and the

DC power cable length cannot exceed 50m.

3. The cable must conform to the local wiring codes according to environmental conditions (temperature and natural conditions).
4. Each part of the system must maintain a connected earth ground.
 - a. Refer to Appendix P: Ground Screw Location, Ground Wire Size.
 - ii. Before hardwiring the UPS unit, ensure that there is no power on the wires, use lock-out tag-out at the breaker panel / local disconnect.
 - iii. Remove the protective cover on the terminal block housing on the back of the UPS.
 - iv. Feed the input cable through a provided cable gland and appropriate hole on terminal block housing. **Note:** Ensure that the cable gland is separated on each side of the terminal block house to allow for the cable to be secured to the housing.
 - v. Crimp a ring terminal onto each wire with a standard crimping tool for the wire size.
 - vi. Connect each wire under the appropriate screw as indicated on the back of the UPS (see the appropriate wire connection diagram in Figures 69 - 72 and bus jumpers in Figure 85). **Note:** Each part of the system must maintain a connected earth ground.
 - vii. After completing the wiring, confirm again that all wiring is correct.
 - viii. Tighten the cable gland to the terminal block housing to secure the cable to the UPS.
 - ix. Leave the terminal block cover off the housing for the next step of connecting the load(s).
2. Connect the load(s) to the UPS:
 - a. All 3-phase UPS units (10-20kVA) have a hardwire output (U10N32V, U10S32V, U15N32V, U15S32V, U20N32V, U20S32V).
 - i. The wired connections must be appropriately sized.
 1. Refer to the table below for the output power cable to be used based on the configuration of the UPS unit being deployed (3-phase in and 3-phase out or 3-phase in and single-phase out).
 - a. If the rated voltage is 400 V, multiply the currents by 0.95. If the rated voltage is 415 V, multiply the currents by 0.92.
 - b. If primary loads are non-linear loads, increase the cross-sectional areas of neutral wires by 1.5 to 1.7 times.
 2. The cable must conform to the local wiring code according to environmental conditions (temperature and natural conditions).
 3. Each part of the system must maintain a connected earth ground.
 - ii. Before hardwiring the UPS unit outputs, ensure that there is no power on the terminals.
 - iii. The protective cover on the terminal block should already be removed from the last step.

- iv. Feed the output cable(s) through provided cable gland(s) and appropriate hole on terminal block housing. **Note:** Ensure that the cable gland is separated on each side of the terminal block house to allow for the cable to be secured to the housing.
- v. Crimp a ring terminal onto each wire with a standard crimping tool for the wire size.
- vi. Connect each wire under the appropriate screw as indicated on the back of the UPS (see the appropriate wire connection diagram in Figures 69 - 72 and bus jumpers in Figure 85). **Note:** Each part of the system must maintain a connected earth ground.
- vii. After completing the wiring, confirm again that all wiring is correct.
- viii. Tighten the cable gland to the terminal block housing to secure the cable to the UPS.
- ix. Leave the terminal block cover off the housing for the next step of connecting the EBP unit(s).

Wire Specification of Power Cables for Single Feed

SKU	Wiring	Number of Phases	Voltage	Current Full Load*** (maximum)	External Input Circuit Breaker (typical)	Wire Size* (typical)
U10N32V	Input	3	380/400/415 VAC	26.9 A each phase	100 A**	25 mm ^{2**}
	Output	1	220/230/240 VAC	45.5 A	not required	16 mm ²
U15N32V	Input	3	380/400/415 VAC	26.9 A each phase	40 A each phase	10 mm ²
	Output	3	380/400/415 VAC	15.2 A each phase	not required	6 mm ²
	Input	3	380/400/415 VAC	34.9 A each phase	100 A**	25 mm ^{2**}
	Output	1	220/230/240 VAC	68.2 A	not required	16 mm ²
U20N32V	Input	3	380/400/415 VAC	34.9 A each phase	40 A each phase	10 mm ²
	Output	3	380/400/415 VAC	22.8 A each phase	not required	6 mm ²
	Input	3	380/400/415 VAC	42.9 A each phase	125 A**	35 mm ^{2**}
	Output	1	220/230/240 VAC	90.9 A	not required	25 mm ²
U20N32V	Input	3	380/400/415 VAC	42.9 A each phase	50 A each phase	16 mm ²
	Output	3	380/400/415 VAC	30.4 A each phase	not required	10 mm ²

Wire Specification of Power Cables for Dual Feed

SKU	Wiring	Number of Phases	Voltage	Current Full Load*** (maximum)	External Input Circuit Breaker Mains (typical)	External Input Circuit Breaker Bypass (typical)	Wire Size Mains* (typical)	Wire Size Bypass* (typical)
U10N32V	Input Output	3 1	380/400/415 VAC 220/230/240 VAC	26.9 A each phase 45.5 A	40 A each phase Not required	100 A ** not required	10 mm ² 16 mm ²	25 mm ^{2**} 16 mm ²
	Input Output	3 3	380/400/415 VAC 380/400/415 VAC	26.9 A each phase 15.2 A each phase	40 A each phase Not required	40 A each phase not required	10 mm ² 6 mm ²	10 mm ² 6 mm ²
U15N32V	Input Output	3 1	380/400/415 VAC 220/230/240 VAC	34.9 A each phase 68.2 A	40 A each phase Not required	100 A ** not required	10 mm ² 16 mm ²	25 mm ^{2**} 16 mm ²
	Input Output	3 3	380/400/415 VAC 380/400/415 VAC	34.9 A each phase 22.8 A each phase	40 A each phase Not required	40 A each phase not required	10 mm ² 6 mm ²	10 mm ² 6 mm ²
U20N32V	Input Output	3 1	380/400/415 VAC 220/230/240 VAC	42.9 A each phase 90.9 A	50 A each phase Not required	125 A ** not required	16 mm ² 25 mm ²	35 mm ^{2**} 25 mm ²
	Input Output	3 3	380/400/415 VAC 380/400/415 VAC	42.9 A each phase 30.4 A each phase	50 A each phase Not required	50 A each phase not required	16 mm ² 10 mm ²	16 mm ² 10 mm ²

*Terminal screw tightening torque: 4.5Nm (40 in-lbs.).

Use cables and input circuit breakers specified in above table. **Note: Units configured for three phase input and single-phase output operation. The entire load connected to the UPS will transfer to L1 and Neutral of the 3-phase input when the UPS is operating in Bypass mode.

***The current is specified at nominal input voltage.

3. Connect the EBP(s) to the UPS (see Figure 73):

- a. As indicated in the mounting section, the EBP should be mounted under or near the UPS.

Note: For setups involving separate battery cabinets, an extended EBP Power Cable (5m) is available as an optional accessory. (UVP10T20VCBL)

- b. All 3-phase EBP units (UVP480) **power connections** are hardwired to the

- UPS units (U10x32V, U15x32V, U20x32V).
- i. For the first EBP connected to the UPS, use the battery cable included with the UPS. This cable has ring terminals on one end and a battery cable connector on the other end.
 - c. **Note:** Before connecting the EBP to the UPS system with the battery cable, first connect an appropriately sized ground wire from the ground screw on the back of the last chassis in the system to a ground screw on the back of the EBP unit being connected.
 - i. The ground wire between the UPS and EBP and each successive EBP unit and the ground screw location is specified in [Appendix P: Ground Screw Location, Ground Wire Size](#).
 - d. Before wiring the EBP to the UPS, ensure there is no power on the UPS battery terminals.
 - e. The protective cover on the terminal block should already be removed from the last step.
 - f. Feed the battery cable(s) through provided cable gland(s) and appropriate hole on terminal block housing. **Note:** Ensure that the cable gland is separated on each side of the terminal block house to allow for the cable to be secured to the housing.
 - g. Connect each wire under the appropriate screw as indicated on the back of the UPS (see the appropriate diagram in Figures 69 - 72). **Note:** Each part of the system (input, battery, and load) must maintain a connected earth ground.
 - h. Connect an appropriately sized ground wire from the terminal block to a ground screw on the back of the first and each successive EBP unit.
 - i. The ground wire between the UPS and EBP and each successive EBP unit and the ground screw location is specified in Appendix P: Ground Screw Location, Ground Wire Size.
 - i. After completing the wiring, confirm again that all wiring is correct.
 - j. Close the terminal block cover on the rear panel of the UPS and secure it with the screws retained from an earlier step.
 - k. Plug the other end of this cable into the back of the EBP. Either battery connector on the back of the EBP unit. Insert and press the connector tightly together to ensure a proper connection. There should be a positive click when the connector is fully inserted.
 - l. For additional EBP units in the system, connect an appropriately sized ground wire from the ground screw on the back of the last EBP unit to a ground screw on the back of the added EBP unit.

Note: Refer to [Appendix M](#) for Ground screw locations and suggested grounding examples.
 - m. Then connect the EBP battery cable provided with the EBP between the last EBP unit and the added EBP unit. Fully insert and press the connector tightly to ensure a proper connection. There should be a positive click when the connector is fully inserted.
 - n. Verify that the EBP connections are tight, and that adequate bend radius and strain relief exist for each cable. This system may have up to 8 EBP units connected.

- o. Additionally, the **UVP480** EBP units come with a two-wire battery temperature cable. This cable must be connected to the port labeled **BAT_T** on the rear panel of the UPS and EBP. Only one EBP BAT_T cable needs to be connected to each UPS.

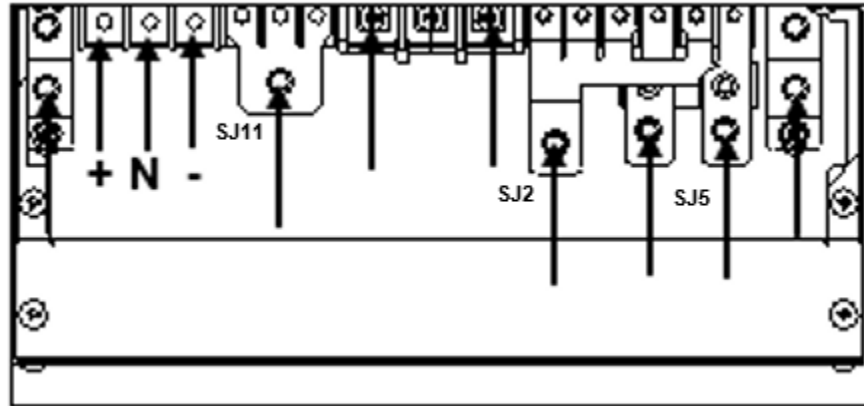

Earth	BATTERY			OUTPUT				INPUT							Earth	
GRD	+	N	-	L1	L2	L3	N	Bps-N	Mains-N	Bps-L1	Mains-L1	Bps-L2	Mains-L2	Bps-L3	Main-L3	GRD

Figure 69: UPS Wiring Connections for a Single Feed with 3-Phase IN and Single-Phase OUT System [Jumpers = SJ2, SJ5, and SJ11]

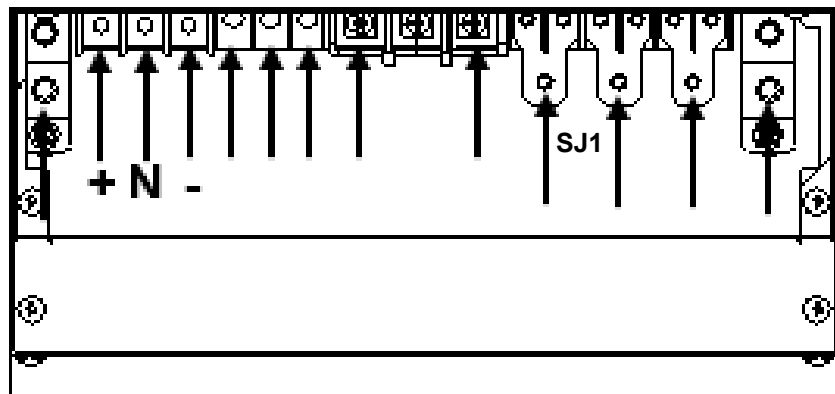

Earth	BATTERY			OUTPUT				INPUT							Earth	
GRD	+	N	-	L1	L2	L3	N	Bps-N	Mains-N	Bps-L1	Mains-L1	Bps-L2	Mains-L2	Bps-L3	Main-L3	GRD

Figure 70: UPS Wiring Connections for a Single Feed with 3-Phase IN and 3-Phase OUT System [Jumpers = 3x SJ1] – Factory Default Wiring

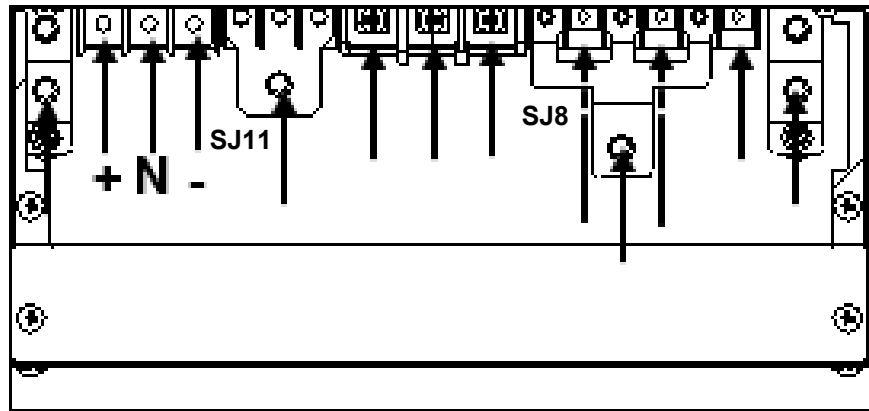

Earth	BATTERY			OUTPUT				INPUT								Earth
GRD	+	N	-	L1	L2	L3	N	Bps-N	Mains-N	Bps-L1	Mains-L1	Bps-L2	Mains-L2	Bps-L3	Main-L3	GRD

Figure 71: UPS Wiring Connections for a Dual Feed with 3-Phase IN and Single-Phase OUT System [Jumpers = SJ8 and SJ11]

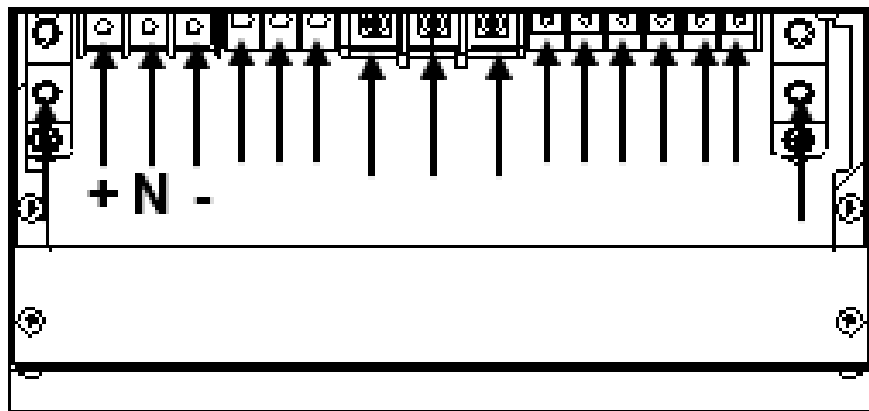

Earth	BATTERY			OUTPUT				INPUT								Earth
GRD	+	N	-	L1	L2	L3	N	Bps-N	Mains-N	Bps-L1	Mains-L1	Bps-L2	Mains-L2	Bps-L3	Main-L3	GRD

Figure 72: UPS Wiring Connections for a Dual Feed with 3-Phase IN and 3-Phase OUT System [Jumpers = none]

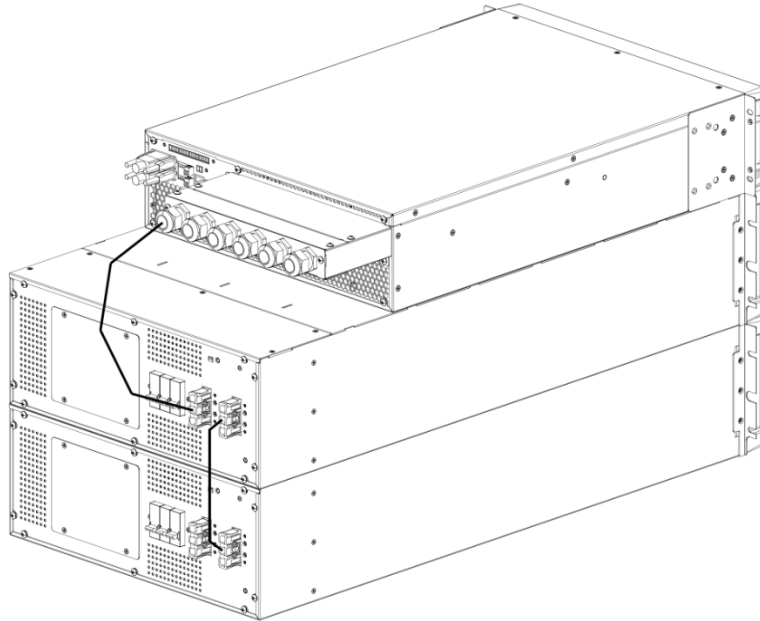

Figure 73: Example of a System with 2 EBP (VRLA) Units Connected

- Power up the system:
 - p. After all electrical connections have been made, the system may be powered up.
 - i. Ensure all breakers in the system are turned on.
 1. Power ON all breakers on the back of each EBP in the system.
Note: All EBP units have a single breaker on the back of the unit. This breaker must be powered on for the EBP to function in the system.
 2. Power ON all UPS output breakers. Refer to the appropriate Panduit 5-20kVA UPS User Manual for the location of the input breaker on each UPS unit.
 3. Power ON all UPS input breakers. Refer to the appropriate Panduit 5-20kVA UPS User Manual for the location of the input breaker on each UPS unit.
 - ii. Remove the lock out tag out from the breaker panel and turn ON the panel breaker(s) for the UPS system.
 - iii. The system should start to power up. **Refer to the appropriate Panduit 5-20kVA UPS User Manual** to properly configure the system for use.
 - iv. Suggested options for configuration upon initial installation:
These are the minimum options that should be configured after initial power up of the system. Other options could be configured later. However, if the system being powered up is a parallel system, then the parallel configurations must also be configured at initial power up.

Display Menu Path	Parameters	Default Value	Options	Description
Setup/ Basic	Language	English	English, Simplified Chinese	Select the language required for the UPS Display Interface. Language options vary by model and firmware version.
	Password	123456	6 digits	The password must be 6 characters, numbers only. For security, this password should be changed after initial power up.
	Date & Time	2022-01-01 & 07:00:00	YYYY-MM-DD, HH:MM:SS	Enter the current date and time (Note: time is 24-hour format).
Setup/ Advanced	Output Setup	Depends on SKU (NA = 208V, EU = 230V)	Depends on SKU	Set the output voltage for the UPS. This setting can only be changed when the UPS output is off.
	Battery Install Date	UPS Manuf. Date	YY-MM-DD	This setting will set the start date to determine when the battery notification and alarm will activate in the future. It is suggested to change this to the date of installation to better monitor battery replacement timing. Changing this date may also clear any pop-ups or warnings related to battery maintenance upon initial installation. Note: Battery Installation date is a system level setting. Setting unique battery installation dates for multiple batteries is not supported.
	No Battery Warning	Disable	Enable / Disable	Recommended to set alarm to 'Enable'. Note: If the battery is disconnected and this option is set to 'Disable', there will be no alarm visible on the UPS display or through the network card.

Parallel Mode System Configuration for 3-Phase Units with 3-Phase or Single-Phase Output (U10N32V, U10S32V, U15N32V, U15S32V, U20N32V, U20S32V)

This section provides the electrical connections for two or more UPS units in a Parallel Mode System with a 3-Phase input and a 3-Phase or a Single-Phase Output.

All 3-phase UPS units may optionally be configured into a Parallel Mode system. The following Figure shows the high-level power and control connection diagrams of the Parallel Mode UPS system. A Parallel Mode system allows two to four UPS units of the same SKU to be connected in parallel.

Note: The parallel mode allows the connected group of UPS units to behave as one large UPS system thereby increasing the maximum load capacity of the system.

SKU	Max. Load Capacity 2 units in parallel.	Max. Load Capacity 3 units in parallel.	Max. Load Capacity 4 units in parallel.
U10N32V	20 kVA	30 kVA	40 kVA
U15N32V	30 kVA	45 kVA	60 kVA
U20N32V	40 kVA	60 kVA	80 kVA

Note: Redundant units are not calculated in the overall capacity of the parallel system.

Note: There are critical restrictions for connecting these units in parallel.

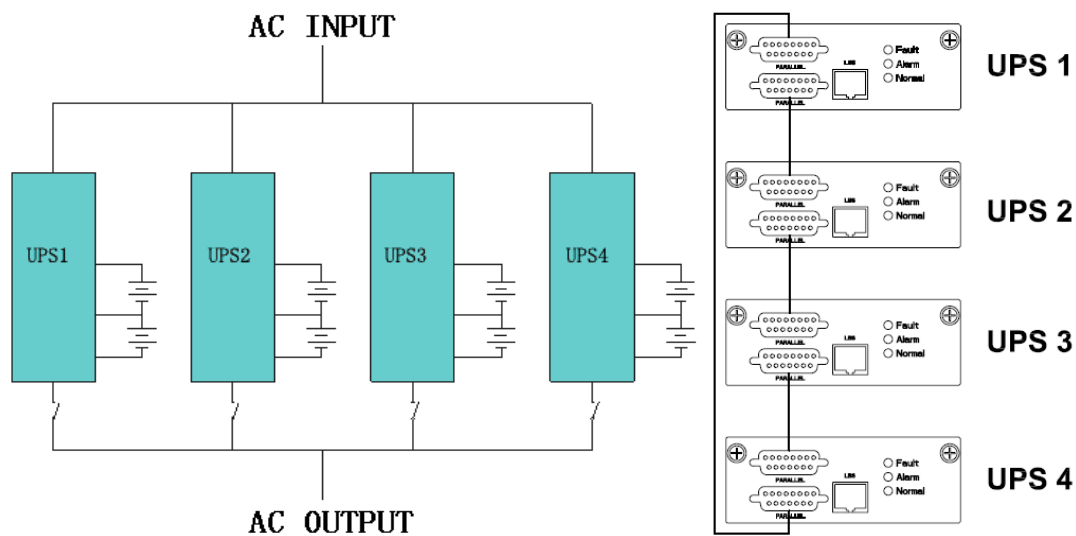

Figure 74: Parallel System Power/Control Connections (3-Phase UPS)

To ensure that all UPS units in the system are equally utilized and comply with relevant wiring rules, follow the requirements below:

- All UPS units in the system must be the same SKU.
- All UPS units in the system must be connected to the same Input Mains source.
- All UPS units in the system must be connected to the same Input Bypass source.
- All UPS units in the system must be connected to a common output bus.
- The length and specification of all UPS power cables (mains input, bypass input, and the output cables) must be the same type and same length. This helps to facilitate load sharing between the UPS units when operating in all working modes.

- The UPS units should be physically located near each other to minimize the load sharing effects due to environmental conditions.

Parallel Mode Wiring for 3-Phase UPS units (U10N32V, U10S32V, U15N32V, U15S32V, U20N32V, U20S32V)

Follow the power and control wiring as indicated in Figure 74.

7. Connect the UPS Parallel System to the input source:
 - a. Before wiring together, make sure each UPS input breaker is in the “OFF” position and there is no output from any UPS unit.
 - b. Connect the Mains inputs of all UPS units in the parallel system to a common source with the same cable type and cable length (see Figures 69 – 73).
Note: Each part of the system (input, battery, and load) must maintain a connected earth ground.
 - c. If single feed, connect the bypass inputs of all UPS units in the parallel system to the same common source as the Mains inputs with the same cable type and cable length (see Figures 69 – 72 and 74).
 - d. If dual feed, connect the bypass inputs of all UPS units in the parallel system to a common source with the same cable type and cable length (see Figures 69 – 72 and 74).
 - e. With the above restriction on the input cables, follow the steps shown in the [Single Mode System Configuration with 3-Phase or Single-Phase Output](#) section for wiring each UPS input in the Parallel Mode System (Step 1).
8. Connect the EBP(s) to the UPS:
 - a. Follow the steps shown in the [Single Mode System Configuration with 3-Phase or Single-Phase Output](#) section for wiring each EBP unit to each UPS in the Parallel Mode System (Step 3).
9. Connect the Parallel System Control (see Figure 74):
 - a. Connect the shielded and double insulated control cables (one provided with each 3-Phase UPS unit) in a ring configuration between UPS units in the parallel system as shown in Figure 74. The ring configuration ensures high reliability of the control.
10. Parallel Mode Setup and Startup:
 - a. Each UPS unit in the Parallel mode system must be properly configured before the Parallel mode system output is connected. Refer to the “Parallel Mode Setup and Startup” section in the UPS 5-20kVA User Manual.
11. Connect the UPS Parallel System to the common output bus:
 - a. Connect the outputs of each UPS unit in the parallel system through an external breaker to a common output bus with the same breaker type, same cable type, and same cable length (see Figures 69 - 72 and 74). **Note:** Each part of the system (input, battery, and load) must maintain a connected earth ground.
 - b. Outputs of all units in the parallel system must be connected the same way – as a single-phase output or as a three-phase output.
 - c. With the above restriction on the output cables, follow the steps shown in the

[Single Mode System Configuration with 3-Phase or Single-Phase Output](#)
section for wiring each UPS output in the Parallel Mode System (Step 2).

12. Power up the system:

- a. After all electrical connections have been made and the parallel configuration has been completed, the system may be powered up.
- Ensure all breakers in the system are turned on.
 - Power ON all breakers on the back of each EBP in the system. **Note:** All EBP units have a single breaker on the back of the unit. This breaker must be powered on for the EBP to function in the system.
 - Power ON all UPS output breakers. Refer to the 5-20kVA UPS User Manual for the location of the output breakers on each UPS unit.
 - Power ON all UPS input breakers. Refer to the 5-20kVA UPS User Manual for the location of the input breakers on each UPS unit.
 - Remove the lock out tag out from the breaker panel and turn ON the panel breaker(s) for the UPS system.
 - The system should start to power up. Refer to the 5-20kVA UPS User Manual to properly configure the system for use.

Optional MBS for 3-Phase UPS

This section provides the electrical connections for the UPS unit to be optionally connected through a Maintenance Bypass Switch. The optional Maintenance Bypass Switch allows the UPS to be isolated and removed from the system to perform periodic maintenance.

All 3-phase UPS units may optionally be connected through a Maintenance Bypass Switch unit. Figures 75 through 78 show the high-level power connection diagrams of the UPS system with the Maintenance Bypass Switch. Select the appropriate figure depending on the UPS system being deployed (single feed or dual feed, 3-phase in and single-phase out, or 3-phase in and 3-phase out).

This section provides the electrical connections for Single Mode System with a 3-Phase input optionally connected as a Single-Phase or a 3-Phase Output. The MBS is not supported in a Parallel Mode System.

- When selecting, connecting, and routing power cables, follow local safety regulations and rules.
- If external conditions such as cable layout or ambient temperatures change, verify in accordance with the IEC-60364-5-52 or local regulations.

The MBS is part of the system and must maintain a connected earth ground (MBS, UPS, EBP, loads).

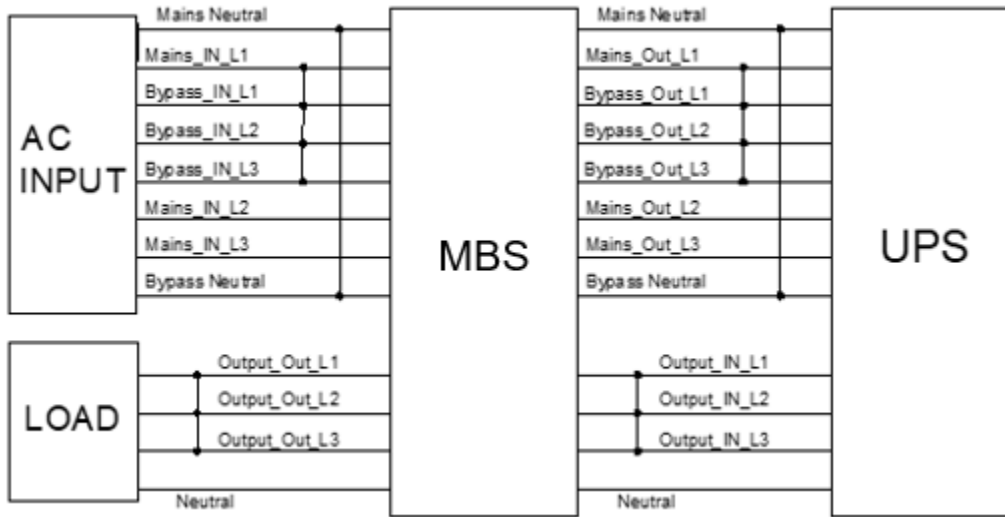

Figure 75: Wiring Diagram for Single Feed with 3-Phase Input and Single-Phase Output

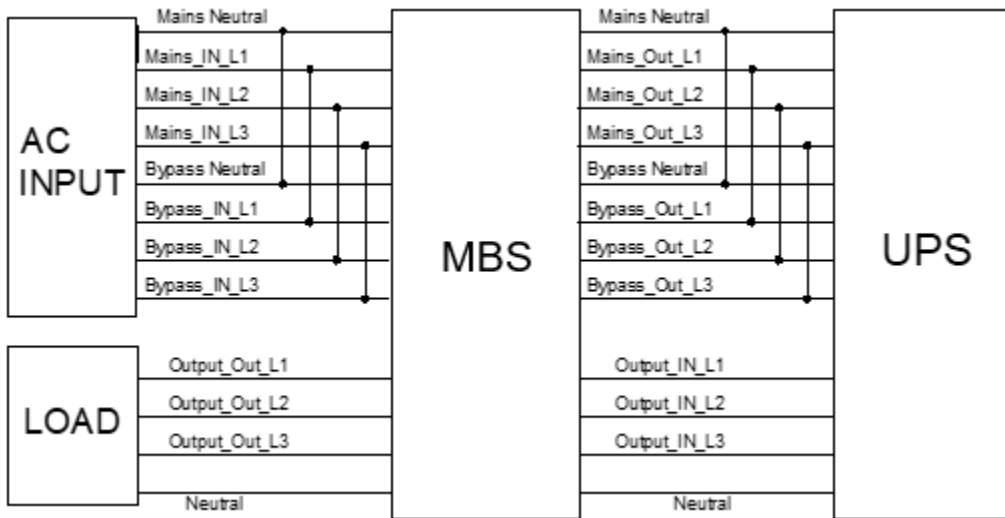

Figure 76: Wiring Diagram for Single Feed with 3-Phase Input and 3-Phase Output

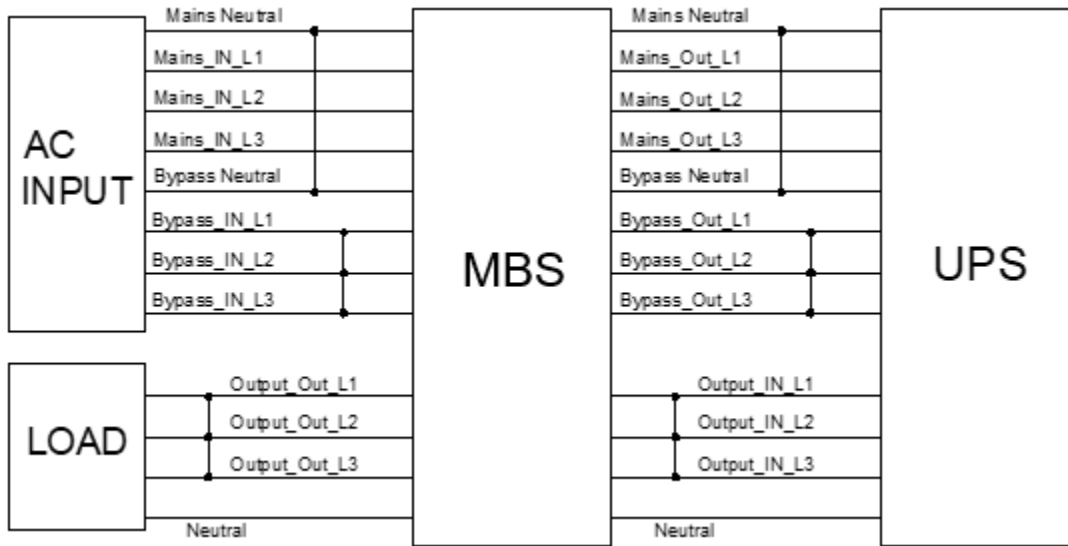

Figure 77: Wiring Diagram for Dual Feed with 3-Phase Input and Single-Phase Output

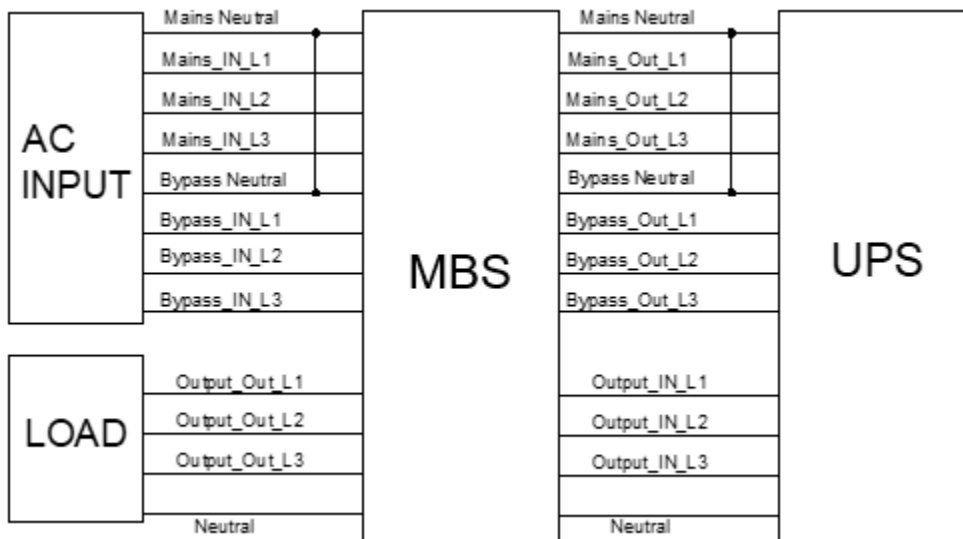

Figure 78: Wiring Diagram for Dual Feed with 3-Phase Input and 3-Phase Output

1. Connect the MBS to the input source.
 - a. The MBS unit has a hardwire input (UMB20K).
 - i. The wired connections must be appropriately sized and protected.
 1. Refer to the table below for the properly rated breaker and wire size in the cable used.
 - a. If the rated voltage is 400 V, multiply the currents by 0.95. If the rated voltage is 415 V, multiply the currents by 0.92.
 2. When the mains input and bypass input have the same input power source (known as single feed), configure both types of input power cables as mains input power cables. The cables listed in the table must adhere to the following requirements:
 - a. Routing mode: Routing the cables over the cable ladder or bracket in a single layer (IEC60364-5-52 middle E).
 - b. The maximum ambient temperature should be 30°C.
 - c. The AC voltage loss must be less than 3%, and the DC voltage loss must be less than 1%.
 - d. Must use 90°C rated or higher copper flexible cable.
 - e. The AC power cable length cannot exceed 30m and the DC power cable length cannot exceed 50m.
 3. The cable must conform to the local wiring codes according to environmental conditions (temperature and natural conditions).
 4. Each part of the system must maintain a connected earth ground.
 - ii. Before hardwiring the MBS unit, ensure that there is no power on the wires. Use lock-out tag-out at the breaker panel / local disconnect.
 - iii. Remove the protective cover on the terminal block housing on the back of the MBS.
 - iv. Feed the input cable through a provided cable gland and appropriate hole on terminal block housing. **Note:** Ensure that the cable gland is separated on each side of the terminal block house to allow for the cable to be secured to the housing.
 - v. Crimp a ring terminal onto each wire with a standard crimping tool for the wire size.
 - vi. Connect each wire under the appropriate screw as indicated on the back of the MBS (see the appropriate wire connection diagram in Figures 79 - 82 and bus jumpers in Figure 85). **Note:** Each part of the system must maintain a connected earth ground.
 - vii. After completing the wiring, confirm again that all wiring is correct.
 - viii. Tighten the cable gland to the terminal block housing to secure the cable to the MBS.
 - ix. Leave the terminal block cover off the housing for the next step of connecting the load(s).

2. Connect the load(s) to the MBS:
 - a. The MBS unit has a hardwire output load (UMB20K).
 - i. The wired connections must be appropriately sized.
 1. Refer to the table below for the output power cable to be used based on the UPS unit being deployed.
 - a. If the rated voltage is 400 V, multiply the currents by 0.95. If the rated voltage is 415 V, multiply the currents by 0.92.
 - b. If primary loads are non-linear loads, increase the cross-sectional areas of neutral wires by 1.5 to 1.7 times.
 2. The cable must conform to the local wiring code according to environmental conditions (temperature and natural conditions).
 3. Each part of the system must maintain a connected earth ground.
 - ii. Before hardwiring the MBS unit outputs, ensure that there is no power on the terminals.
 - iii. The protective cover on the terminal block should already be removed from the last step.
 - iv. Feed the output cable(s) through provided cable gland(s) and appropriate hole on terminal block housing. **Note:** Ensure that the cable gland is separated on each side of the terminal block house to allow for the cable to be secured to the housing.
 - v. Crimp a ring terminal onto each wire with a standard crimping tool for the wire size.
 - vi. Connect each wire under the appropriate screw as indicated on the back of the MBS (see the appropriate wire connection diagram in Figures 79 - 82 and bus jumpers in Figure 85). **Note:** Each part of the system must maintain a connected earth ground.
 - vii. After completing the wiring, confirm again that all wiring is correct.
 - viii. Tighten the cable gland to the terminal block housing to secure the cable to the UPS.
 - ix. Leave the terminal block cover off the housing for the next step of connecting the UPS unit.
 - a. Follow the steps as shown in the [Single Mode System Configuration with 3-Phase or Single-Phase Output](#) section (Step 1), except the UPS input cables will be coming from the MBS instead of hardwires from a breaker panel.
3. Connect the UPS input to the MBS.
 - a. Follow the steps as shown in the [Single Mode System Configuration with 3-Phase or Single-Phase Output](#) section (Step 1), except the UPS input cables will be coming from the MBS instead of hardwires from a breaker panel.
4. Connect the UPS output to the MBS.
 - a. Follow the steps as shown in the [Single Mode System Configuration with 3-Phase or Single-Phase Output](#) section (Step 2), except the UPS output cables will be going to the MBS instead of to the load(s).
5. Connect the UPS system EBP to the UPS.
 - a. Follow the steps as shown in the “Single Mode System Configuration with 3-Phase or Single-Phase Output” section (Step 3).
6. Connect both ends of the Maintenance Bypass Switch Sensor Cable and Output Breaker Sensor cables (included with the MBS) from their respective ports in the

rear panel of the UPS to the ports in the rear panel of the MBS. These ports are labeled as “MAINT. & OUTPUT.”

Wire Specification of Power Cables for Single Feed

SKU	Wiring	Number of Phases	Voltage	Current Full Load*** (maximum)	External Input Circuit Breaker (typical)	Wire Size* (typical)
U10N32V	Input	3	380/400/415 VAC	26.9 A each phase	100 A**	25 mm ^{2**}
	Output	1	220/230/240 VAC	45.5 A	not required	16 mm ²
U15N32V	Input	3	380/400/415 VAC	26.9 A each phase	40 A each phase	10 mm ²
	Output	3	380/400/415 VAC	15.2 A each phase	not required	6 mm ²
U15N32V	Input	3	380/400/415 VAC	34.9 A each phase	100 A**	25 mm ^{2**}
	Output	1	220/230/240 VAC	68.2 A	not required	16 mm ²
U20N32V	Input	3	380/400/415 VAC	34.9 A each phase	40 A each phase	10 mm ²
	Output	3	380/400/415 VAC	22.8 A each phase	not required	6 mm ²
U20N32V	Input	3	380/400/415 VAC	42.9 A each phase	125 A**	35 mm ^{2**}
	Output	1	220/230/240 VAC	90.9 A	not required	25 mm ²
U20N32V	Input	3	380/400/415 VAC	42.9 A each phase	50 A each phase	16 mm ²
	Output	3	380/400/415 VAC	30.4 A each phase	not required	10 mm ²

Wire Specification of Power Cables for Dual Feed

SKU	Wiring	Number of Phases	Voltage	Current Full Load*** (maximum)	External Input Circuit Breaker Mains (typical)	External Input Circuit Breaker Bypass (typical)	Wire Size Mains* (typical)	Wire Size Bypass* (typical)
U10N32V	Input Output	3 1	380/400/415 VAC 220/230/240 VAC	26.9 A each phase 45.5 A	40 A each phase Not required	100 A ** not required	10 mm ² 16 mm ²	25 mm ² ** 16 mm ²
	Input Output	3 3	380/400/415 VAC 380/400/415 VAC	26.9 A each phase 15.2 A each phase	40 A each phase Not required	40 A each phase not required	10 mm ² 6 mm ²	10 mm ² 6 mm ²
U15N32V	Input Output	3 1	380/400/415 VAC 220/230/240 VAC	34.9 A each phase 68.2 A	40 A each phase Not required	100 A ** not required	10 mm ² 16 mm ²	25 mm ² ** 16 mm ²
	Input Output	3 3	380/400/415 VAC 380/400/415 VAC	34.9 A each phase 22.8 A each phase	40 A each phase Not required	40 A each phase not required	10 mm ² 6 mm ²	10 mm ² 6 mm ²
U20N32V	Input Output	3 1	380/400/415 VAC 220/230/240 VAC	42.9 A each phase 90.9 A	50 A each phase Not required	125 A ** not required	16 mm ² 25 mm ²	35 mm ² ** 25 mm ²
	Input Output	3 3	380/400/415 VAC 380/400/415 VAC	42.9 A each phase 30.4 A each phase	50 A each phase Not required	50 A each phase not required	16 mm ² 10 mm ²	16 mm ² 10 mm ²

*Terminal screw tightening torque: 4.5Nm (40 in-lbs.).

Use cables and input circuit breakers specified in the table above. **Note: For units configured for three phase input and single-phase output operation, the entire load connected to the UPS will transfer to L1 and Neutral of the 3-phase input when the UPS is operating in Bypass mode.

***The current is specified at nominal input voltage.

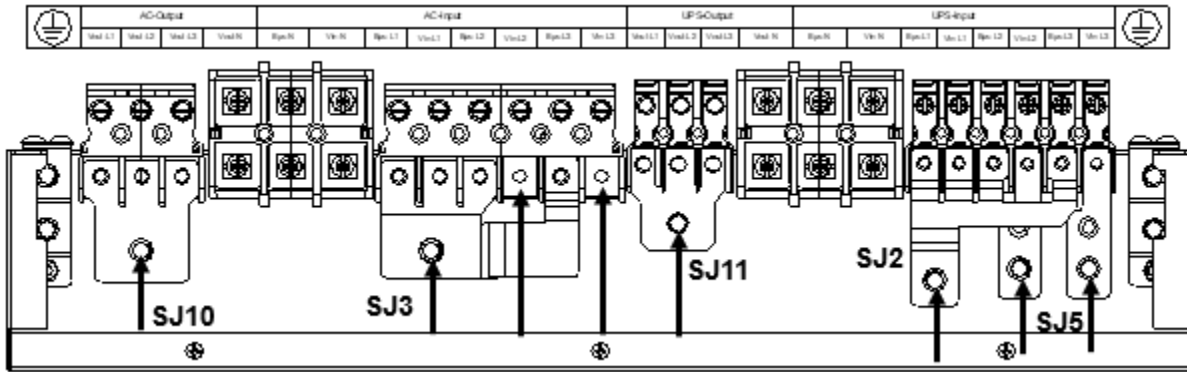

Figure 79: MBS Wiring Connections for a Single Feed with 3-Phase In and Single-Phase Out System [Jumpers = SJ2, SJ3, SJ5, SJ10 and SJ11]

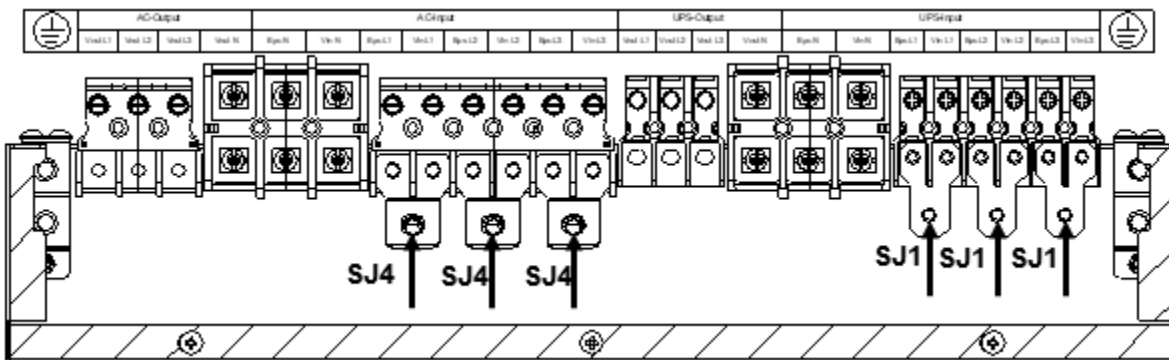

Figure 80: MBS Wiring Connections for a Single Feed with 3-Phase In and 3-Phase Out System [Jumpers = 3x SJ1 and 3x SJ4] (Factory Default)

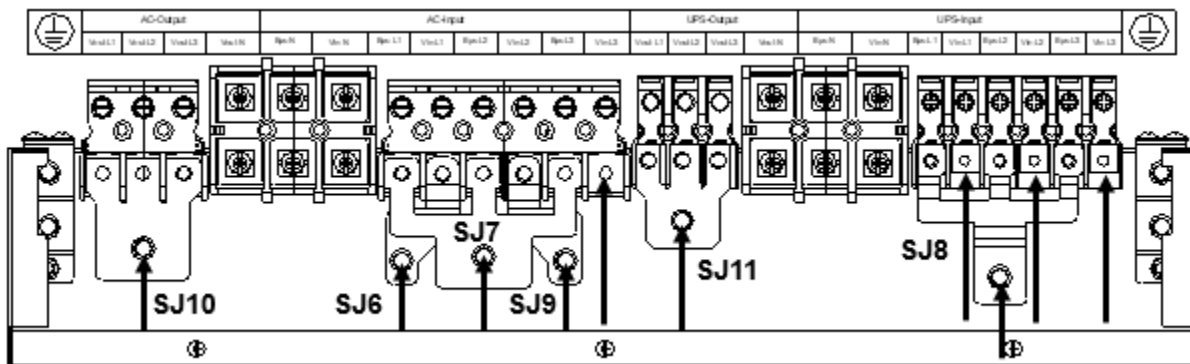

Figure 81: MBS Wiring Connections for a Dual Feed with 3-Phase In and Single-Phase Out System [Jumpers = SJ6, SJ7, SJ8, SJ9, SJ10, SJ11]

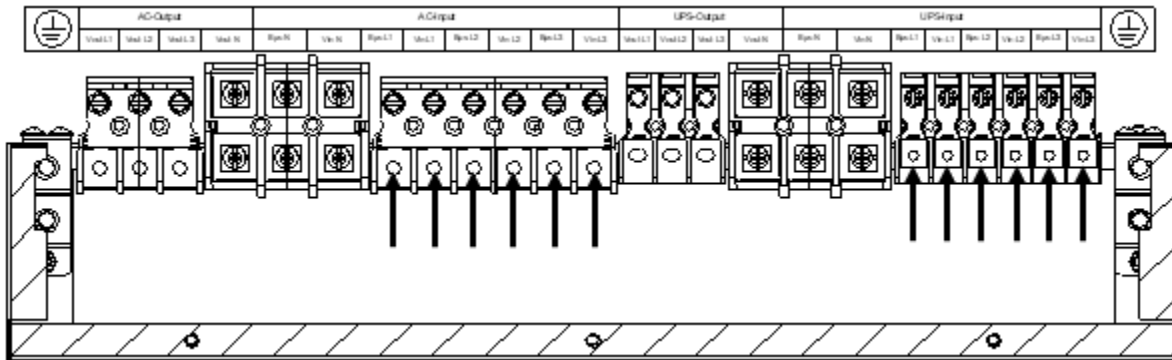

Figure 82: MBS Wiring Connections for a Dual Feed with 3-Phase In and 3-Phase Out System [Jumpers = NA]

Optional MBS (UMB20K) Usage for 1-Phase UPS (5-10kVA EU Region Only)

This section provides the electrical connection option for the single phase 5-10kVA EU region UPS units to the Maintenance Bypass Switch (UMBK20). The optional Maintenance Bypass Switch allows the UPS to be isolated and removed from the system to perform periodic maintenance.

Note: In this configuration the Mains input terminals on the MBS will not be used. (Refer to *Figure 83* below) There is no OUTPUT port on the rear panel of the 5-10kVA EU UPS units. This output breaker detection feature will not be used.

- When selecting, connecting, and routing power cables, follow local safety regulations and rules.
- If external conditions such as cable layout or ambient temperatures change, verify in accordance with the IEC-60364-5-52 or local regulations.
- The MBS is part of the system and must maintain a connected earth ground (MBS, UPS, EBP, loads).

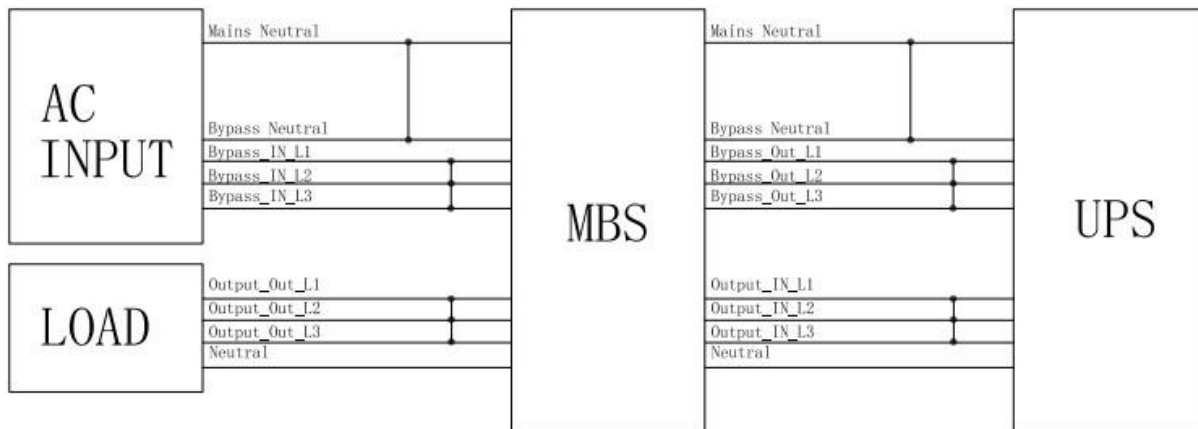

Figure 83: Wiring Diagram for Single-phase Input to Single Phase Output (EU region UPS units only)

1. Connect the MBS to the input source.
 - a. The MBS unit has a hardwire input (UMB20K).
 - i. The wired connections must be appropriately sized and protected.
 1. This option only supports single feed input cables. The cables must adhere to the following requirements:
 - a. Routing mode: Routing the cables over the cable ladder or bracket in a single layer (IEC60364-5-52 middle E).
 - b. The maximum ambient temperature should be 30°C.
 - c. The AC voltage loss must be less than 3%, and the DC voltage loss must be less than 1%.
 - d. Must use 90°C rated or higher copper flexible cable.
 - e. The AC power cable length cannot exceed 30m and the DC power cable length cannot exceed 50m.
 2. The cable must conform to the local wiring codes according to environmental conditions (temperature and natural conditions).
 3. Each part of the system must maintain a connected earth ground.
 - ii. Before hardwiring the MBS unit, ensure that there is no power on the wires. Use lock-out tag-out at the breaker panel / local disconnect.
 - iii. Remove the protective cover on the terminal block housing on the back of the MBS.
 - iv. Feed the input cable through a provided cable gland and appropriate hole on terminal block housing. **Note:** Ensure that the cable gland is separated on each side of the terminal block house to allow for the cable to be secured to the housing.
 - v. Crimp a ring terminal onto each wire with a standard crimping tool for the wire size.

- vi. Connect each wire under the appropriate screw as indicated on the back of the MBS (see Figure 84 below). **Note:** Only the Bypass terminals on the MBS will be used for this connection. The mains terminals on the MBS will not be used in this configuration. Each part of the system must maintain a connected earth ground.
 - vii. After completing the wiring, confirm again that all wiring is correct.
 - viii. Tighten the cable gland to the terminal block housing to secure the cable to the MBS.
 - ix. Leave the terminal block cover off the housing for the next step of connecting the load(s).
2. Connect the load(s) to the MBS:
 - a. The MBS unit has a hardwire output load (UMB20K).
 - i. The wired connections must be appropriately sized.
 1. If primary loads are non-linear loads, increase the cross-sectional areas of neutral wires by 1.5 to 1.7 times.
 2. The cable must conform to the local wiring code according to environmental conditions (temperature and natural conditions).
 3. Each part of the system must maintain a connected earth ground.
 - ii. Before hardwiring the MBS unit outputs, ensure that there is no power on the terminals.
 - iii. The protective cover on the terminal block should already be removed from the last step.
 - iv. Feed the output cable(s) through provided cable gland(s) and appropriate hole on terminal block housing. **Note:** Ensure that the cable gland is separated on each side of the terminal block house to allow for the cable to be secured to the housing.
 - v. Crimp a ring terminal onto each wire with a standard crimping tool for the wire size.
 - vi. Connect each wire under the appropriate screw as indicated on the back of the MBS (see Figure 84 below). **Note:** Each part of the system must maintain a connected earth ground.
 - vii. After completing the wiring, confirm again that all wiring is correct.
 - viii. Tighten the cable gland to the terminal block housing to secure the cable to the UPS.
 - ix. Leave the terminal block cover off the housing for the next step of connecting the UPS unit.
 3. Connect the UPS input to the MBS.
 - a. Follow the input wiring steps detailed in **Section 4 1-10kVA Single-Phase UPS and Associated EBP**, except the UPS input cables will be coming from the MBS instead of hardwires from a breaker panel. **Note:** Only the Bypass terminals on the MBS will be used in this configuration.
 4. Connect the UPS output to the MBS.
 - a. Follow the output wiring steps detailed in **Section 4 1-10kVA Single-Phase UPS and Associated EBP**, except the UPS output cables will be going to the MBS instead of to the load(s).

5. Connect the UPS system EBP to the UPS.
 - a. Follow the steps detailed in **Section 4 1-10kVA Single-Phase UPS and Associated EBP.**
6. Connect both ends of the Maintenance Bypass Switch Sensor Cable (included with the MBS) from the respective port in the rear panel of the UPS to the port in the rear panel of the MBS. This port is labeled as “MAINT.”

Important: For 5-10kVA VRLA UPS units containing core system **FW v030 or earlier**, the MAINT port on the UPS rear panel should be left normally unoccupied. This cable should only be plugged in to the UPS rear panel when engaging the Maintenance Bypass mode for system maintenance. FW version may be found on the touch-screen display after system bootup.

Note: The MBS Output breaker sense cable from the MBS unit (UMB20K) will not be used and output breaker detection will not be available for the single phase MBS configuration.

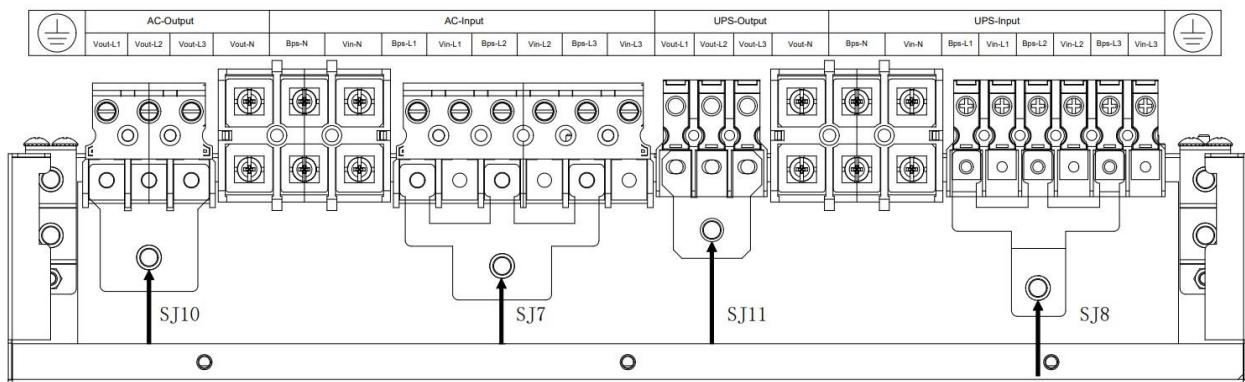
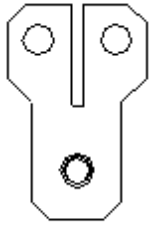
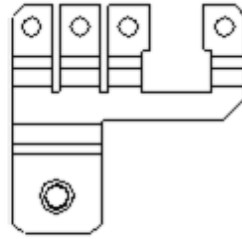

Figure 84: MBS Wiring Connections for a Single-phase In and Single-Phase Out System (5-10kVA EU UPS units only) [Jumpers = SJ7, SJ8, SJ10, SJ11]

SJ1



SJ2



SJ3

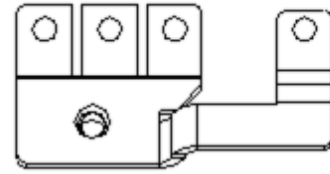

SJ4

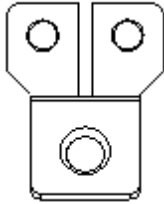

SJ5

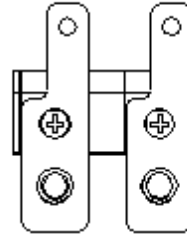

SJ6

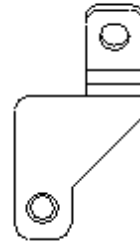

SJ7

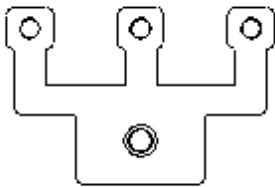

SJ8

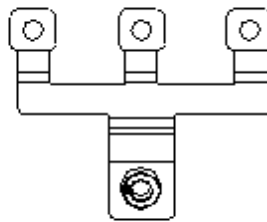

SJ9

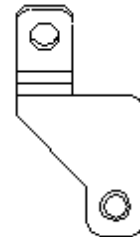

SJ10

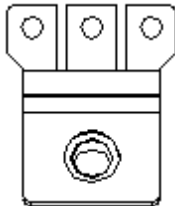

SJ11

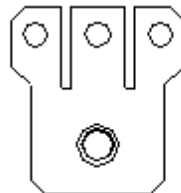

Figure 85: Bus Bar Jumpers

Section 5 – Replacing Battery Cartridges

Internal Battery Cartridges in the 1-3kVA UPS Units (UVC024, UVC036, UVC048, UVC072, ULC024, ULC048, ULC272, ULC372)

Replace battery cartridges only with the same SKU. It is recommended to replace all battery cartridges in a system at the same time with new battery cartridges of the same SKU for that unit (UPS and EBP).

1. Change the UPS in the system to the Bypass state. This will not allow the UPS to transition to Battery state while the battery cartridges are being replaced.
2. Turn off the breaker on the back of all the EBP units in the system. This will reduce arching while the battery connects and disconnects are being made. **Note:** All battery cartridges in the system should be changed at the same time. It is not recommended to mix new battery cartridges and old battery cartridges in a system.
3. Remove the faceplate:
 - a. Press both sides of UPS faceplate until the latches release (see figure below).

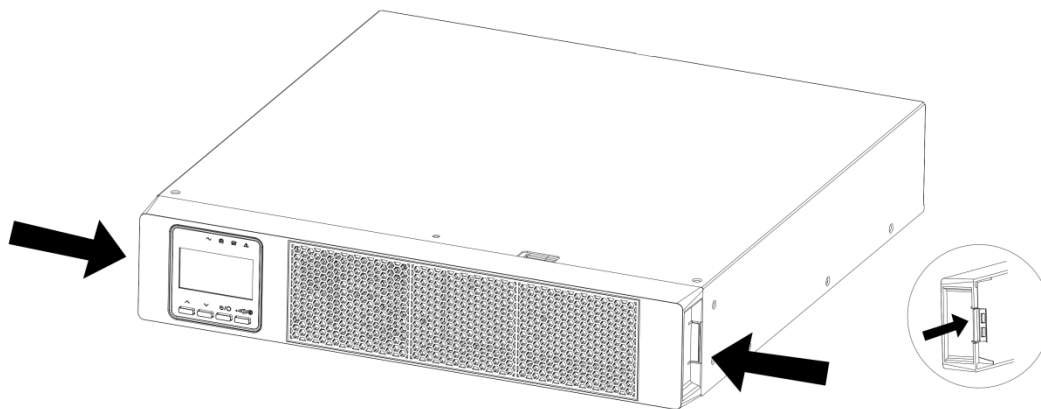

Figure 86: Press the Latches to Remove Faceplate

- Remove the faceplate (see figure below).

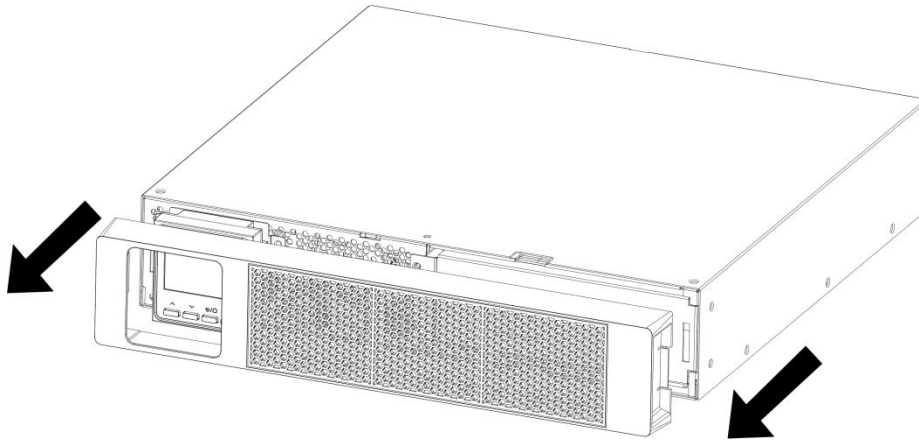

Figure 87: Remove the Faceplate

4. Replace the Battery Cartridge:
 - a. Disconnect the internal battery cartridge connector (see figure below).

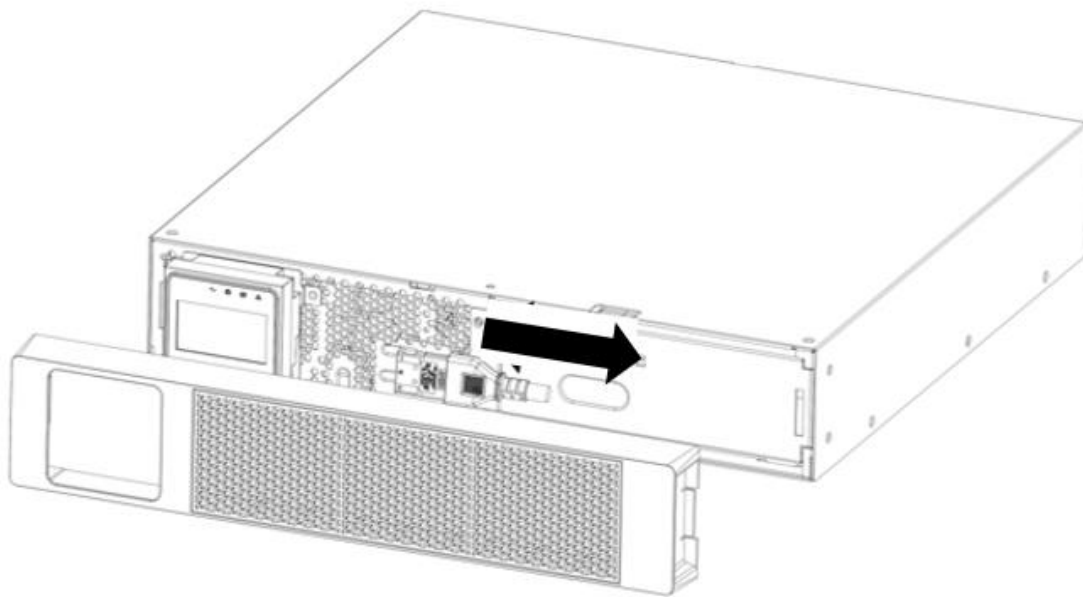

Figure 88: Disconnect the Internal Battery Cartridge Connector

- b. Remove and retain the screws (2x screws toward the center of the unit) on the battery cover, slide the battery cover toward the center of the unit, then remove the battery cover from the unit (see figure below).

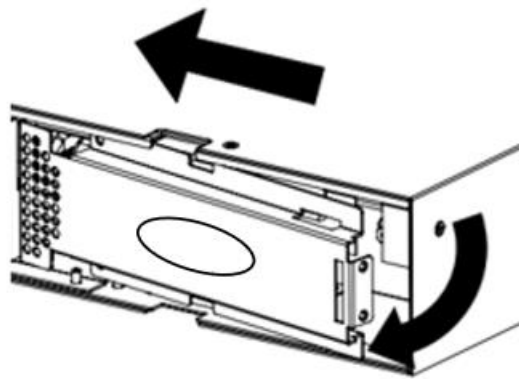

Figure 89: Remove Battery Cover

- c. Slide the battery cartridge connector through the hole in the battery cover and set the battery cover aside.
 - d. Slide the battery cartridge out of the UPS.
 - e. Slide the new battery cartridge into the UPS.
 - f. Slide the new battery cartridge connector through the hole in the battery cover.
 - g. Replace and secure the battery cover (reverse order of above).
 - h. Connect the new battery cartridge to the UPS. Press connector tightly together to ensure a proper connection.
 - i. Replace the UPS faceplate.
5. If EBP units are part of the system, perform the EBP Battery Cartridge replacements on all the EBP units in the system before changing the UPS back to the Normal state.
 6. Change the UPS in the system back to the Normal state.
 7. Allow time for the UPS to transition to the Normal state (about 30 seconds).
 8. **Note:** If adding or removing EBP units to the system at the same time, appropriately adjust battery capacity on the system in the UPS (see UPS 1-3kVA User Manual – Setup Operation – Double Conversion VRLA UPS – Screen 4) before running the manual battery test.
 9. Manually run a battery test to ensure the full capacity battery is connected.

EBP Battery Cartridge Sets for the 1-3kVA VRLA UPS Systems (UVD024, UVD036, UVD048, UVD072)

Replace battery cartridges only with the same SKU. It is recommended to replace all battery cartridges in the system at the same time with new battery cartridges of the same SKU for that unit (EBP).

1. The UPS should still be in the Bypass state from the above steps.
2. The breaker on the back of each EBP unit should be off from the above steps.

3. Perform the following steps on each EBP in the system.
 - a. Remove the faceplate by pressing on both sides of EBP faceplate until the latches release and are removed (see figure below).

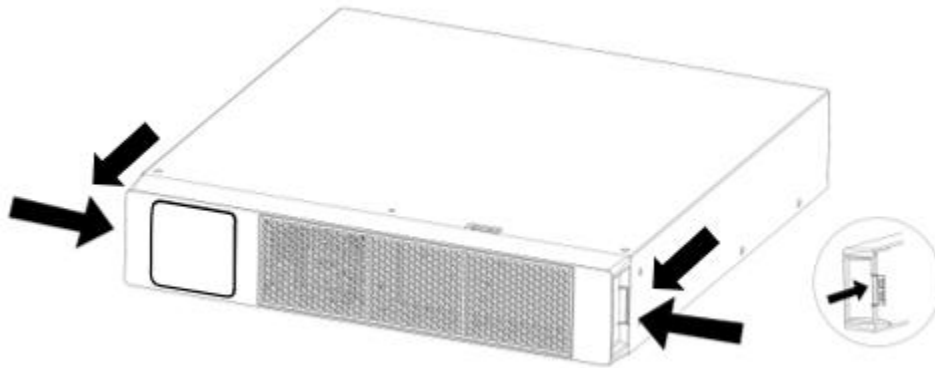

Figure 90: Press the Latches and Remove Faceplate

- b. Loosen and remove the two screws on top and bottom each battery cover near the center of the unit, slide the battery cover toward the center, then remove and retain all 4 screws and 2 battery covers (see figure below).

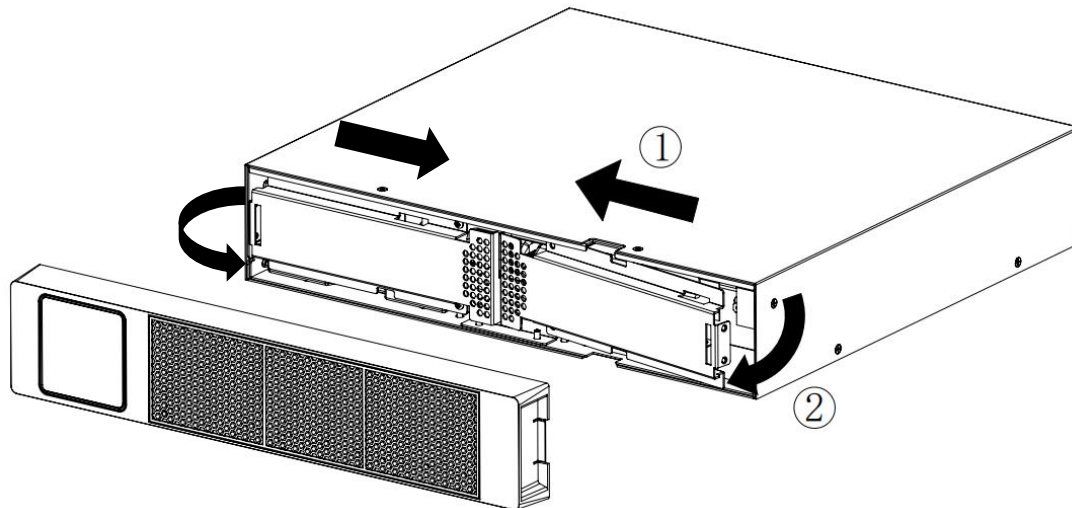

Figure 91: Remove the Faceplate

- c. Pull both battery cartridge connectors through the middle hole in the chassis. Disconnect the battery cartridges from each connector.

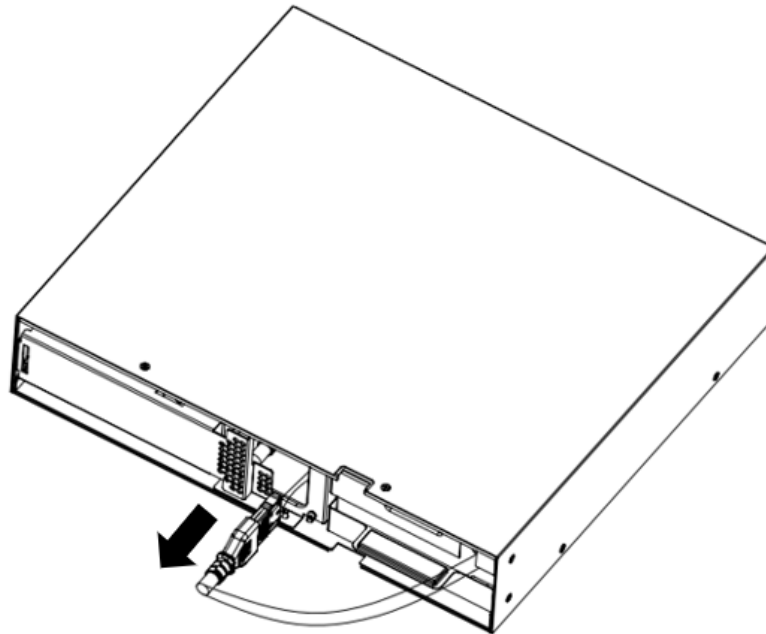

Figure 92: Disconnect the First Internal Battery Cartridge Connector

- d. Slide both battery cartridges out of the UPS.
 - e. Slide the new battery cartridges into the UPS.
 - f. Connect the new battery cartridges to the EBP. Press each connector tightly together to ensure a proper connection.
 - g. Slide both battery cartridge connectors through the middle hole in the chassis.
 - h. Replace both battery covers (reverse order of above steps).
 - i. Replace the EBP faceplate.
 - j. Turn the breaker on the back of the EBP unit to the ON position.
 - k. Repeat the above steps for each of the EBP units in the system.
4. After all the EBP battery cartridges in the system have been replaced and are connected to the system, change the UPS in the system back to the Normal state.
 5. Allow time for the UPS to transition to the Normal state (about 30 seconds).
 6. **Note:** If adding or removing EBP units to the system at the same time, appropriately adjust battery capacity on the system in the UPS (see 1-3kVA UPS User Manual – Setup Operation – Double Conversion VRLA UPS – Screen 4) before running the manual battery test.
 7. Manually run a battery test to ensure the battery cartridges are connected.

EBP Battery Cartridge Sets for the 5-10kVA VRLA UPS Systems (UVD240)

Replace battery cartridges only with the same SKU. It is recommended to replace all battery cartridges in the system at the same time with new battery cartridges of the same SKU for that unit (EBP).

1. Change the UPS in the system to the Bypass state. This will prevent the UPS from transitioning to the Battery state while the battery cartridges are being replaced.
2. Perform the following steps on each EBP in the system.
 - a. Turn OFF both breakers on the back of the EBP. This will reduce arcing while connecting and disconnecting the battery cartridges.
 - b. Remove the faceplate by pressing both sides of EBP faceplate until the latches release (see figure below). Then remove the faceplate from the front of the unit.

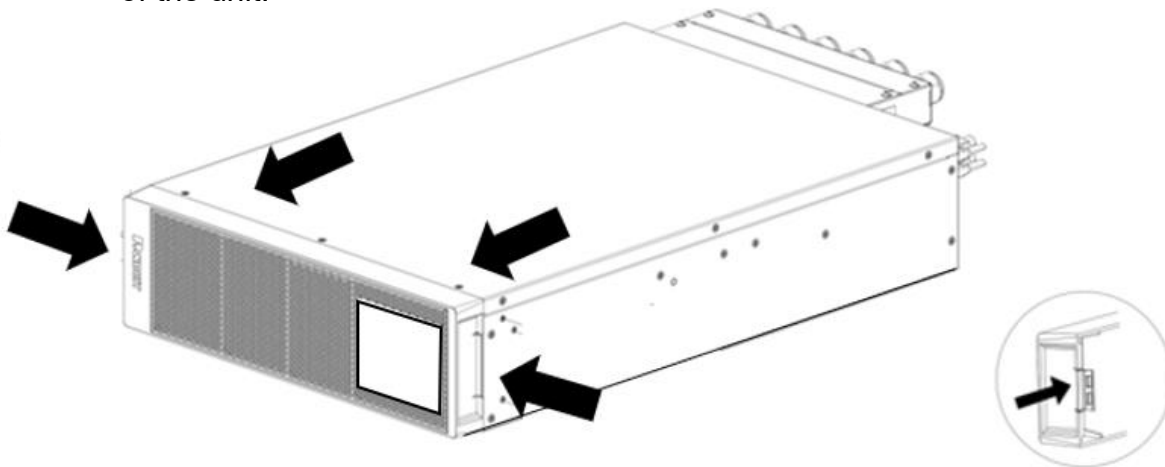

Figure 93: Press the Latches to Remove Faceplate

- c. Disconnect all four battery cartridge connectors (see figure below).

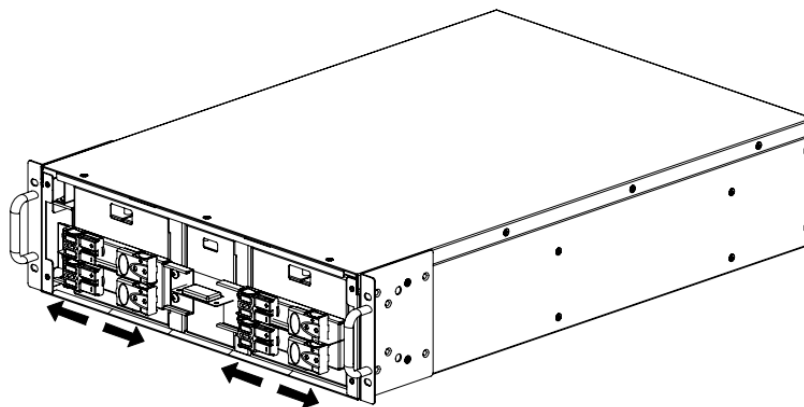

Figure 94: Disconnect Internal Battery Cartridges

- d. Remove the battery baffle screws and baffles and retain (see figure below).

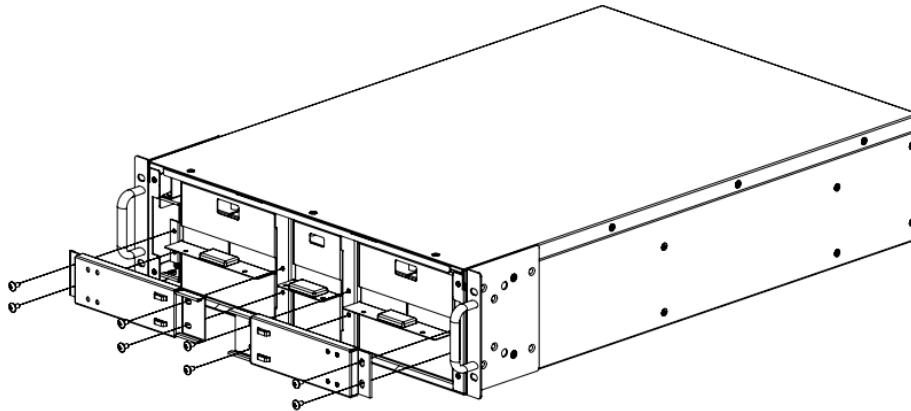

Figure 95: Remove the Battery Baffles

- e. Referring to the handling instructions, take out all three battery cartridges (see figure below). Slide the two larger (8 batteries) battery cartridges and one smaller (4 batteries) battery cartridge out of the EBP unit.

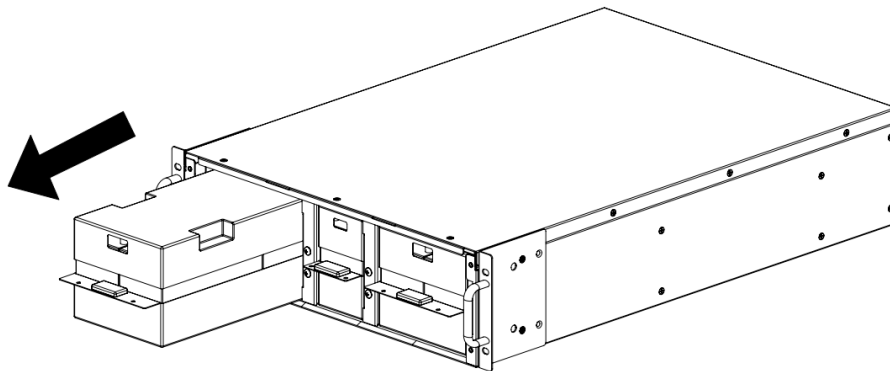

Figure 96: Remove Battery Cartridges from EBP

- f. Referring to the handling instructions, slide the three new battery cartridges into the EBP unit.
- g. Reinstall the battery baffles the screws (reverse order of above steps).
- h. Connect the new battery cartridges to the EBP. Press each connector tightly together to ensure a proper connection. The larger battery cartridges connect to connectors 1 and 3, while each half of the smaller battery cartridge connects to connectors 2 and 4.
- i. Replace the EBP faceplate.
- j. Turn both breakers on the back of EBP unit to the ON position.
3. After all the EBP battery cartridges in the system have been replaced and are

- connected to the system, change the UPS in the system back to the Normal state.
4. Allow time for the UPS to transition to the Normal state (about 30 seconds).
 5. **Note:** If adding or removing EBP units to the system at the same time, appropriately adjust battery group number on the system in the UPS (see 5-20kVA UPS User Manual – Section 2 – Display Operations – Setup Pages – Setup Menu Page – Advanced Setup Menu Page – Battery Setup Page) before running the manual battery test.
 6. Manually run a battery test to ensure that all battery cartridges are connected.

EBP Battery Cartridge Sets for the 10-20kVA 3-Phase VRLA UPS Systems (UVD480)

Replace battery cartridges only with the same SKU. It is recommended to replace all battery cartridges in the system at the same time with new battery cartridges of the same SKU for that unit (EBP).

1. Change the UPS in the system to the Bypass state. This will prevent the UPS from transitioning to the Battery state while the battery cartridges are being replaced.
2. Perform the following steps on each EBP unit in the system:
 - a. Turn OFF breaker on the back of each EBP. This will reduce arcing while the battery connections are being connected and disconnected.
 - b. Remove the faceplate by pressing both sides of EBP faceplate until the latches release (see figure below). Then remove the faceplate from the front of the unit.

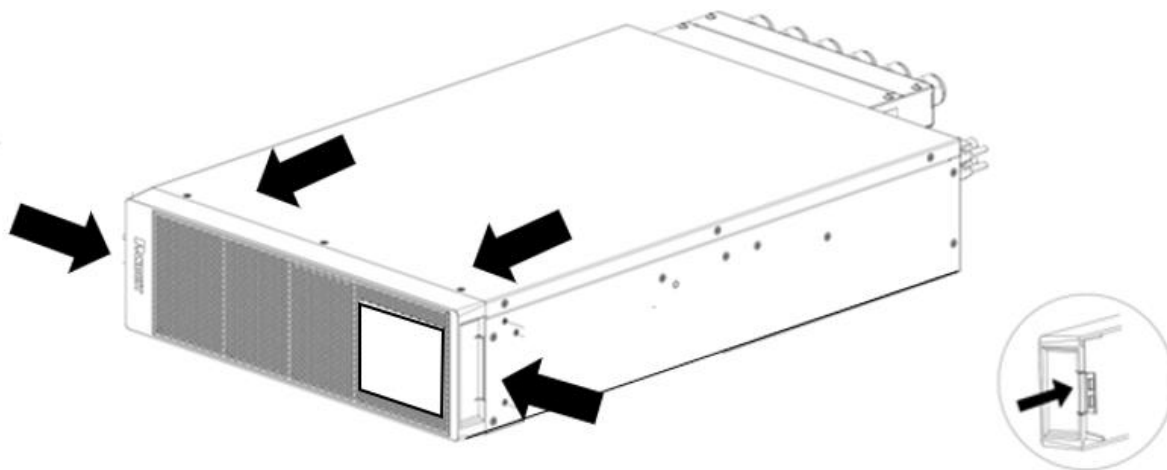

Figure 97: Press the Latches to Remove Faceplate

- c. Remove and retain the screws (8) and battery baffle from the EBP (see figure below).

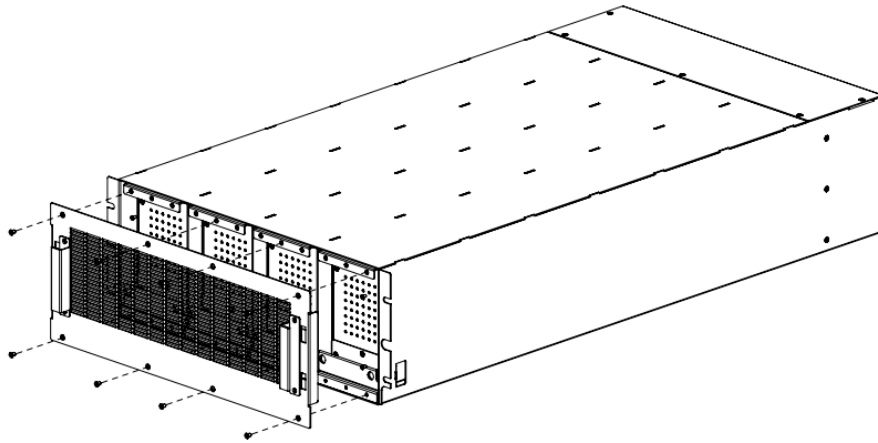

Figure 98: Remove Battery Baffle on the EBP

- d. Referring to the handling instructions, remove all four battery cartridges. Battery cartridges are connected to a backplane in this EBP unit. There is some resistance when removing the cartridges (see figure below). **Note:** The Battery Cartridge is heavy.

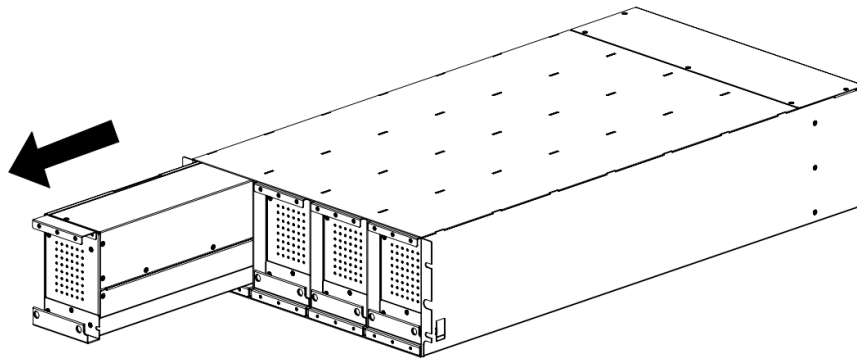

Figure 99: Remove Battery Cartridges from EBP

- e. Referring to the handling instructions, slide the new battery cartridges into the EBP unit, battery cartridges are connected to a backplane in the unit. There will be some resistance when inserting the cartridges.
- f. Reinstall the battery baffle the screws (reverse order of above steps).
- g. Replace the EBP faceplate.
- h. Turn the breaker on the back of the EBP unit to the ON position.
3. After all the EBP battery cartridges in the system have been replaced and are connected to the system, change the UPS in the system back to the Normal state.
4. Allow time for the UPS to transition to the Normal state (about 30 seconds).
5. **Note:** If adding or removing EBP units to the system at the same time, appropriately

adjust battery group number on the system in the UPS (see 5-20kVA UPS User Manual – Section 2 – Display Operations – Setup Pages – Setup Menu Page – Advanced Setup Menu Page – Battery Setup Page) before running the manual battery test.

6. Manually run a battery test to ensure all battery cartridges are connected.

EBP Battery Cartridge Sets for the 1-3kVA Li EBP (UVPL50H) and 5-10kVA Li EBP (UVPL12H)

Lithium-ion EBPs do NOT have user replaceable batteries. When these batteries are at the end of life, the entire EBP must be replaced with the same model number.

Appendix A: What's Included: 1-3kVA NA VRLA UPS (U01N11V, U01S11V, U01N13V, U01S13V, U02N11V, U02S11V, U03N11V, U03S11V,)

- 1-3kVA Double Conversion North American VRLA 1-Phase 120V UPS unit depending on the UPS SKU ordered (1 unit)
- Tower Mount Kit (with 4 pieces)
- 2U UPS Front Faceplate (1 piece)
- Rack Mounting Brackets (2 pieces)
- Safety Warning Sheet (1 sheet)
- Documentation Kit (items may vary)
- Internal Battery Cartridge Installed [UVC036, UVC024, UVC048 or UVC072 depending on UPS SKU] (1 cartridge)
- 2-pin EPO Plug with shorting wire installed (1 piece)
- Rack Rail Mounting Kit [URMKIT2] (1 kit) – N versions only
- Left Slide Rail (1 rail mechanism)
- Right Slide Rail (1 rail mechanism)
- Phillips Pan Head M5x12 Screw (12 screws)
- Phillips Hex Head M5x25 Screw (4 screws)
- M5 Cage Nut (4 cage nuts)
- Rail Installation Sheet (1 sheet)
- Intelligent Network Card Installed with two #0 Phillips screws [UNCP01] – N versions only
- Intelligent Slot Cover Plate with two #0 Phillips screws – S versions only

Appendix B: What's Included: 1-3kVA EU VRLA UPS (U01N12V, U01S12V, U02N12V, U02S12V, U03N12V, U03S12V)

- 1-3kVA Double Conversion European VRLA 1-Phase 230V UPS unit depending on the UPS SKU ordered (1 unit)
- Tower Mount Kit (with 4 pieces)
- 2U UPS Front Faceplate (1 piece)
- Rack Mounting Brackets (2 pieces)
- Safety Warning Sheet (1 sheet)
- Documentation Kit (items may vary)
- Internal Battery Cartridge Installed [UVC036, UVC048 or UVC072 depending on UPS SKU] (1 cartridge)
- Schuko CEE7/EU1-16P to C14 or C20 Input Power Cord depending on UPS SKU (1 cable)
- BS1363A to C14 Input Power Cord (1 cable)
- 2-pin EPO Plug with shorting wire installed (1 piece)
- Rack Rail Mounting Kit [URMKIT2] (1 kit) – N versions only
- Left Slide Rail (1 rail mechanism)
- Right Slide Rail (1 rail mechanism)
- Phillips Pan Head M5x12 Screw (12 screws)
- Phillips Hex Head M5x25 Screw (4 screws)
- M5 Cage Nut (4 cage nuts)
- Rail Installation Sheet (1 sheet)
- Intelligent Network Card Installed with two #0 Phillips screws [UNCP01] – N versions only
- Intelligent Slot Cover Plate with two #0 Phillips screws – S versions only

Appendix C: What's Included: 1-3kVA VRLA EBP (UVP024, UVP036, UVP048, UVP072)

- 1-3kVA VRLA External Battery Pack unit depending on the EBP SKU ordered (1 unit)
- Tower Mount Kit (with 4 pieces)
- 2U EBP Front Faceplate (1 piece)
- Rack Mounting Brackets (2 pieces)
- Safety Warning Sheet (1 Sheet)
- Internal Battery Cartridge Set Installed [UVD024, UVD036, UVD048 or UVD072 [depending on EBP SKU ordered] (2 cartridges)
- Rack Rail Mounting Kit [URMKIT2] (1 kit)
 - Left Slide Rail (1 rail mechanism)
 - Right Slide Rail (1 rail mechanism)
 - Phillips Pan Head M5x12 Screw (12 screws)
 - Phillips Hex Head M5x25 Screw (4 screws)
 - M5 Cage Nut (4 cage nuts)
 - Rail Installation Sheet (1 sheet)
- EBP Power Cable – EBP/UPS Battery Connector to EBP/UPS Battery Connector (1 cable)
- Ground Wire with ring terminal on each end (1 piece)

Appendix D: What's Included: 5-10kVA VRLA 1-Phase UPS (U05N11V, U05S11V, U06N11V, U06S11V, U06N12V, U06S12V, U10N11V, U10S11V, U10N12V, U10S12V)

UPS Box

- 5-10kVA Double Conversion VRLA 1-Phase (208V or 230V) UPS unit depending on the UPS SKU ordered (1 unit)
- 3U UPS Front Faceplate (1 piece)
- Tower Mount Kit (6 pieces)
- Rack Mounting Brackets (2 pieces)
- Safety Warning Sheet (1 sheet)
- Documentation Kit (items may vary)
- 2-pin EPO Plug with shorting wire installed (1 piece)
- 2-pin MAINT Plug with shorting wire installed (1 piece)
- Rack Rail Mounting Kit [URMKIT2] (1 kit)
 - Left Slide Rail (1 rail mechanism)
 - Right Slide Rail (1 rail mechanism)
 - Phillips Pan Head M5x12 Screw (12 screws)
 - Phillips Hex Head M5x25 Screw (4 screws)
 - M5 Cage Nut (4 cage nuts)
 - Installation Sheet (1 sheet)
- Insulated Ring Terminal (6 pieces)
- M32 Φ 25mm Cable Gland (2 pieces)
- Intelligent Network Card Installed with two #0 Phillips screws [UNCP01] – N versions only
- Intelligent Slot Cover Plate with two #0 Phillips screws – S versions only

EBP Box

- External Battery Pack unit [UVP240] (1 unit)
- 3U EBP Front Faceplate (1 piece)
- Tower Mount Kit (6 pieces)
- Rack Mounting Brackets (2 pieces)
- Safety Warning Sheet (1 sheet)
- EBP Internal Battery Cartridge Set Installed [UVD240] (3 cartridges)
- External Battery Pack Temperature cable (1 cable)
- Rack Rail Mounting Kit [URMKIT2] (1 kit)
 - Left Slide Rail (1 rail mechanism)
 - Right Slide Rail (1 rail mechanism)
 - Phillips Pan Head M5x12 Screw (12 screws)
 - Phillips Hex Head M5x25 Screw (4 screws)

- M5 Cage Nut (4 cage nuts)
- Installation Sheet (1 sheet)
- EBP Power Cable – EBP/UPS Battery Connector to EBP/UPS Battery Connector (1 cable)

Appendix E: What's Included: 5-10kVA Lithium 1-Phase UPS (U05N11L, U05S11L, U05N12L, U05S12L, U06N11L, U06S11L, U06N12L, U06S12L, U10N11L, U10S11L, U10N12L, U10S12L)

UPS Box

- 5-10kVA Double Conversion Lithium 1-Phase (208V or 230V) UPS unit depending on the UPS SKU ordered (1 unit)
- 2U UPS Front Faceplate (1 piece)
- Tower Mount Kit (4 pieces)
- Rack Mounting Brackets (2 pieces)
- Ground Cable 0.6m (1 cable)
- Safety Warning Sheet (1 sheet)
- Documentation Kit (items may vary)
- DB9 to DB9 RS232 1.5M Parallel Cable (1 cable, black)
- 2-pin EPO Plug with shorting wire installed (1 piece)
- 2-pin MAINT Plug with shorting wire installed (1 piece)
- Rack Rail Mounting Kit [URMKIT2] (1 kit)
 - Left Slide Rail (1 rail mechanism)
 - Right Slide Rail (1 rail mechanism)
 - Phillips Pan Head M5x12 Screw (12 screws)
 - Phillips Hex Head M5x25 Screw (4 screws)
 - M5 Cage Nut (4 cage nuts)
 - Installation Sheet (1 sheet)
- M32 Φ 25mm Cable Gland (2 pieces)
- Intelligent Network Card Installed with two #0 Phillips screws [UNCP01] – N versions only

EBP Box

- External Battery Pack [UVPL12H] (1 unit)
- 2U EBP Front Faceplate (1 piece)
- Tower Mount Kit (4 pieces)
- Rack Mounting Brackets (2 pieces)
- Safety Warning Sheet (1 sheet)
- Documentation Kit (items may vary)
- EBP Power Cable (1 cable)
- EBP to UPS RJ45 Communication Cable (1 cable)
- EBP CAN RJ45 Communication Cable (1 cable)
- Ground Cable (1 cable)

- Rack Rail Mounting Kit [URMKIT2] (1 kit)
 - Left Slide Rail (1 rail mechanism)
 - Right Slide Rail (1 rail mechanism)
 - Phillips Pan Head M5x12 Screw (12 screws)
 - Phillips Hex Head M5x25 Screw (4 screws)
 - M5 Cage Nut (4 cage nuts)
 - Instruction Sheet (1 sheet)

Appendix F: What's Included: 10-20kVA VRLA 3-Phase UPS (U10N32V, U10S32V, U15N32V, U15S32V, U20N32V, U20S32V)

UPS Box

- 10-20kVA UPS depending on the UPS SKU ordered [U10N32V, U10S32V, U15N32V, U15S32V, U20N32V, U20S32V] (1 unit)
- 3U UPS Front Faceplate (1 piece)
- Tower Mount Kit (6 pieces)
- Rack Mounting Brackets (2 pieces)
- Safety Warning Sheet (1 sheet)
- Documentation Kit (items may vary)
- DB15M to DB15F Parallel Cable (1 cable)
- 4-pin EPO Plug with shorting wire installed (1 piece)
- 2-pin MAINT plug with shorting wire installed (1 piece)
- Rack Rail Mounting Kit [URMKIT2] (1 kit)
 - Left Slide Rail (1 rail mechanism)
 - Right Slide Rail (1 rail mechanism)
 - Phillips Pan Head M5x12 Screw (12 screws)
 - Phillips Hex Head M5x25 Screw (4 screws)
 - M5 Cage Nut (4 cage nuts)
 - Rail Installation Sheet (1 sheet)
- SJ1 Bus Bar Jumpers Installed (3 jumpers)
- SJ2 Bus Bar Jumper (1 jumper)
- SJ5 Bus bar Jumper (1 jumper)
- SJ8 Bus Bar Jumper (1 jumper)
- SJ11 Bus Bar Jumper (1 jumper)
- Non-insulated Ring Terminal (24 pieces)
- Heat Shrink for Non-insulated Ring Terminal (24 pieces)
- Hex Phillips Head M4x8 Jumper Screw (6 screws)
- M32 Φ 25mm Cable Gland (6 pieces)
- EBP Power Cable – Ring terminal to EBP Battery Connector (1 cable)
- Intelligent Network Card Installed with two #0 Phillips screws [UNCP01] – N versions only
- Intelligent Slot Cover Plate with two #0 Phillips screws – S versions only

EBP Box

- External Battery Pack unit [UVP480] (1 unit)
- 4U EBP Front Faceplate (1 piece)
- Safety Warning Sheet (1 sheet)
- EBP Internal Battery Cartridge Set Installed [UVD480] (4 cartridges)
- External Battery Pack Temperature Sensor Cable (1 cable)

- Rack Rail Mounting Kit [URM480] (1 kit in EBP)
 - 4U Left Slide Rail (1 rail mechanism)
 - 4U Right Slide Rail (1 rail mechanism)
 - Phillips Pan Head M5x12 Screw (12 screws)
 - M5 Cage Nut (12 cage nuts)
 - Rail Installation Sheet (1 sheet)
- EBP Power Cable – EBP Battery Connector to EBP Battery Connector (1 cable)

Appendix G: What's Included: 5-10kVA VRLA EBP (UVP240)

- External Battery Pack [UVP240] (1 unit)
- 3U EBP Front Faceplate (1 piece)
- Tower Mount Kit (6 pieces)
- Rack Mounting Brackets (2 pieces)
- Safety Warning Sheet (1 sheet)
- Internal Battery Cartridge Set Installed [UVD240] (3 cartridges)
- External Battery Pack Temperature cable (1 cable)
- Rack Rail Mounting Kit [URMKIT2] (1 kit)
 - Left Slide Rail (1 rail mechanism)
 - Right Slide Rail (1 rail mechanism)
 - Phillips Pan Head M5x12 Screw (12 screws)
 - Phillips Hex Head M5x25 Screw (4 screws)
 - M5 Cage Nut (4 cage nuts)
 - Instruction Sheet (1 sheet)
- EBP Power Cable – EBP/UPS Battery Connector to EBP/UPS Battery Connector (1 cable)

Appendix H: What's Included: 5-10kVA Lithium EBP (UVPL12H)

- External Battery Pack [UVPL12H] (1 unit)
- 2U EBP Front Faceplate (1 piece)
- Tower Mount Kit (4 pieces)
- Rack Mounting Brackets (2 pieces)
- Safety Warning Sheet (1 sheet)
- EBP Power Connector Cable (1 cable)
- EBP to UPS RJ45 Communication Cable (1 cable)
- EBP CAN RJ45 Communication Cable (1 cable)
- Rack Rail Mounting Kit [URMKIT2] (1 kit)
 - Left Slide Rail (1 rail mechanism)
 - Right Slide Rail (1 rail mechanism)
 - Phillips Pan Head M5x12 Screw (12 screws)
 - Phillips Hex Head M5x25 Screw (4 screws)
 - M5 Cage Nut (4 cage nuts)
 - Instruction Sheet (1 sheet)

Appendix I: What's Included: 10-20kVA 3-Phase VRLA EBP (UVP480)

- External Battery Pack [UVP480] (1 unit)
- 4U EBP Front Faceplate (1 piece)
- Safety Warning Sheet (1 sheet)
- Internal Battery Cartridge Set Installed [UVD480] (4 cartridges)
- External Battery Pack Temperature cable (1 cable)
- Rack Rail Mounting Kit [URM480] (1 kit)
 - 4U Left Slide Rail (1 rail mechanism)
 - 4U Right Slide Rail (1 rail mechanism)
 - Phillips Pan Head M5x12 Screw (12 screws)
 - M5 Cage Nut (12 cage nuts)
 - Rail Installation Sheet (1 sheet)
- EBP Power Cable – EBP Battery Connector to EBP Battery Connector (1 cable)

Appendix J: What's Included: 3-Phase Maintenance Bypass Switches (UMB20K)

- 10-20kVA MBS [UMB20K] (1 unit)
- Tower Mount Kit (with 6 pieces)
- Rack Mounting Brackets (2 pieces)
- Safety Warning Sheet (1 sheet)
- Documentation Kit (items may vary)
- Bypass Switch Sensor Cable (1 cable)
- Output Breaker Sensor Cable (1 cable)
- Rack Rail Mounting Kit [URMKIT2] (1 kit)
 - Left Slide Rail (1 rail mechanism)
 - Right Slide Rail (1 rail mechanism)
 - Phillips Pan Head M5x12 Screw (12 screws)
 - Phillips Hex Head M5x25 Screw (4 screws)
 - M5 Cage Nut (4 cage nuts)
 - Installation Sheet (1 sheet)
- SJ1 Bus Bar Jumpers Installed (3 jumpers)
- SJ2 Bus Bar Jumper (1 jumper)
- SJ3 Bus Bar Jumper (1 jumper)
- SJ4 Bus Bar Jumpers Installed (3 jumpers)
- SJ5 Bus bar Jumper (1 jumper)
- SJ6 Bus bar Jumper (1 jumper)
- SJ7 Bus bar Jumper (1 jumper)
- SJ8 Bus Bar Jumper (1 jumper)
- SJ9 Bus bar Jumper (1 jumper)
- SJ10 Bus bar Jumper (1 jumper)
- SJ11 Bus Bar Jumper (1 jumper)
- Non-insulated Ring Terminal (44 pieces)
- Heat Shrink for Non-insulated Ring Terminal (44 pieces)
- Hex Phillips Head M4x8 Jumper Screw (6 screws)
- M32 Φ 25mm Cable Gland (7 pieces)

Appendix K: What's Included: 1-3kVA NA Li UPS (U01N11L, U01S11L, U01N14L, U01S14L, U02N11L, U02S11L, U02N14L, U02S14L, U03N11L, U03S11L, U03N14L, U03S14L, U03N15L, U03S15L)

- 1-3kVA North American Li 1-Phase UPS unit (Capacity and input voltage rating varies depending on the UPS SKU ordered) (1 unit)
- Tower Mount Kit (with 4 pieces)
- 2U UPS Front Faceplate (1 piece)
- Rack Mounting Brackets (2 pieces)
- Safety Warning Sheet (1 sheet)
- Documentation Kit (items may vary)
- Internal Battery Cartridge Installed [ULC024, ULC048, ULC272 or ULC372 depending on UPS SKU] (1 cartridge)
- 2-pin EPO Plug with shorting wire installed (1 piece)
- Rack Rail Mounting Kit [URMKIT2] (1 kit) – N versions only
 - Left Slide Rail (1 rail mechanism)
 - Right Slide Rail (1 rail mechanism)
 - Phillips Pan Head M5x12 Screw (12 screws)
 - Phillips Hex Head M5x25 Screw (4 screws)
 - M5 Cage Nut (4 cage nuts)
 - Installation Sheet (1 sheet)
- Intelligent Network Card Installed with two #0 Phillips screws [UNCP01] – N versions only
- Intelligent Slot Cover Plate with two #0 Phillips screws – S versions only

Appendix L: What's Included: 1-3kVA EU Li UPS (U01N12L, U01S12L, U02N12L, U02S12L, U03N12L, U03S12L)

- 1-3kVA Double Conversion European Li 1-Phase 230V UPS unit depending on the UPS SKU ordered (1 unit)
- Tower Mount Kit (with 4 pieces)
- 2U UPS Front Faceplate (1 piece)
- Rack Mounting Brackets (2 pieces)
- Safety Warning Sheet (1 Sheet)
- Documentation Kit (items may vary)
- Internal Battery Cartridge Installed [ULC024, ULC272 or ULC372 depending on UPS SKU] (1 cartridge)
- Schuko CEE7/EU1-16P to C14 or C20 Input Power Cord depending on UPS SKU ordered (1 cable)
- BS1363A to C14 or C20 Input Power Cord depending on the UPS SKU ordered (1 cable)
- 2-pin EPO Plug with shorting wire installed (1 piece)
- Rack Rail Mounting Kit [URMKIT2] (1 kit) – N versions only
 - Left Slide Rail (1 rail mechanism)
 - Right Slide Rail (1 rail mechanism)
 - Phillips Pan Head M5x12 Screw (12 screws)
 - Phillips Hex Head M5x25 Screw (4 screws)
 - M5 Cage Nut (4 cage nuts)
 - Installation Sheet (1 sheet)
- Intelligent Network Card Installed with two #0 Phillips screws [UNCP01] – N versions only
- Intelligent Slot Cover Plate with two #0 Phillips screws – S versions only

Appendix M: What's Included: 1-3kVA NA Li Long Runtime UPS (U01N16L-N, U02N16L-N, U03N16L-N)

- 1-3kVA North American Li 1-Phase Long Runtime UPS unit (Capacity and input voltage rating varies depending on the UPS SKU ordered) with pre-installed Power Cord (1 unit)
- Tower Mount Kit (with 4 pieces)
- 2U UPS Front Faceplate (1 piece)
- Rack Mounting Brackets (2 pieces)
- Safety Warning Sheet (1 sheet)
- Documentation Kit (items may vary)
- 2-pin EPO Plug with shorting wire installed (1 piece)
- Rack Rail Mounting Kit [URMKIT2] (1 kit)
 - Left Slide Rail (1 rail mechanism)
 - Right Slide Rail (1 rail mechanism)
 - Phillips Pan Head M5x12 Screw (12 screws)
 - Phillips Hex Head M5x25 Screw (4 screws)
 - M5 Cage Nut (4 cage nuts)
 - Installation Sheet (1 sheet)
- Intelligent Network Card Installed with two #0 Phillips screws [UNCP01] – N versions only

Appendix N: What's Included: 1-3kVA EU Li Long Runtime UPS (U01N18L-N, U02N18L-N, U03N18L-N)

- 1-3kVA Double Conversion European Li 1-Phase 230V UPS unit depending on the UPS SKU ordered (1 unit)
- Tower Mount Kit (with 4 pieces)
- 2U UPS Front Faceplate (1 piece)
- Rack Mounting Brackets (2 pieces)
- Safety Warning Sheet (1 Sheet)
- Documentation Kit (items may vary)
- Schuko CEE7/EU1-16P to C14 or C20 Input Power Cord depending on UPS SKU ordered (1 cable)
- BS1363A to C14 or C20 Input Power Cord depending on the UPS SKU ordered (1 cable)
- 2-pin EPO Plug with shorting wire installed (1 piece)
- Rack Rail Mounting Kit [URMKIT2] (1 kit)
 - Left Slide Rail (1 rail mechanism)
 - Right Slide Rail (1 rail mechanism)
 - Phillips Pan Head M5x12 Screw (12 screws)
 - Phillips Hex Head M5x25 Screw (4 screws)
 - M5 Cage Nut (4 cage nuts)
 - Installation Sheet (1 sheet)
- Intelligent Network Card Installed with two #0 Phillips screws [UNCP01] – N versions only

Appendix O: What's Included: 1-3kVA Lithium EBP (UVPL50H)

- External Battery Pack [UVPL50H] (1 unit)
- 2U EBP Front Faceplate (1 piece)
- Tower Mount Kit (4 pieces)
- Rack Mounting Brackets (2 pieces)
- Safety Warning Sheet (1 sheet)
- EBP Power Connector Cable (1 cable)
- EBP to UPS RJ45 Communication Cable (1 cable)
- EBP CAN RJ45 Communication Cable (1 cable)
- Rack Rail Mounting Kit [URMKIT2] (1 kit)
 - Left Slide Rail (1 rail mechanism)
 - Right Slide Rail (1 rail mechanism)
 - Phillips Pan Head M5x12 Screw (12 screws)
 - Phillips Hex Head M5x25 Screw (4 screws)
 - M5 Cage Nut (4 cage nuts)
 - Instruction Sheet (1 sheet)

Appendix P: Ground Screw Location, Ground Wire Size, and Recommended Grounding Setup Options.

1-3kVA UPS Units:

Model		Grounding Screw Size	Grounding Wire Gauge	
VRLA	120V	U01S13V	M4	10mm ²
		U01S11V		
		U02S11V		
	230V	U03S11V		
		U01S12V		
		U02S12V		
Lithium	120V	U03S12V	M4	10mm ²
		U01S11L		
		U02S11L		
	230V	U03S11L		
		U01S12L		
		U02S12L		
U03S12L				

Grounding Locations

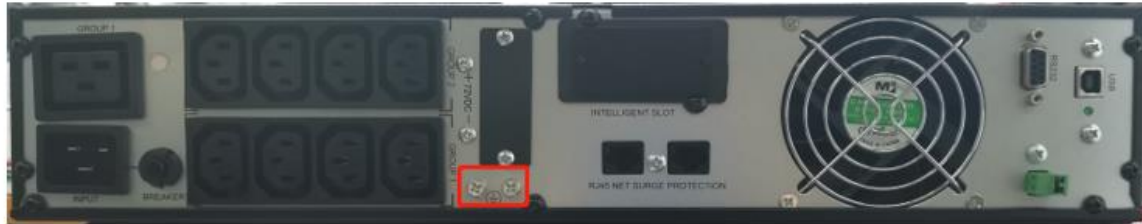

Model		Grounding Screw Size	Grounding Wire Gauge	
Lithium (Double Conversion)	120 V	U01N14L, U01S14L	M4	10mm ²
		U02N14L, U02S14L		
		U03N14L, U03S14L		
	208V	U03N15L, U03S15L	M4	10mm ²

Grounding Locations (U02N14L Example)



1-3kVA UPS Units with EBP:

Model		Grounding Screw Size	Grounding Wire Gauge
Lithium LRT (Double Conversion)	120V	U01N16L-N	10mm ²
		U02N16L-N	
		U03N16L-N	

Grounding Locations (U03N16L-N Example)



Model		Grounding Screw Size	Grounding Wire Gauge
Lithium LRT (Double Conversion)	230V	U01N18L-N	10mm ²
		U02N18L-N	
		U03N18L-N	

Grounding Locations (U01N18L-N Example)

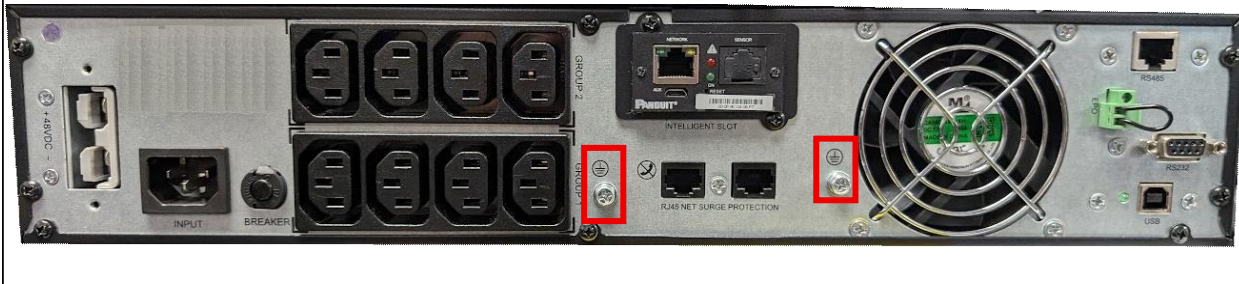

5kVA VRLA UPS Unit:

Model			Grounding Screw Size	Grounding Wire Gauge
VRLA	208V	U05S11V	Chassis: M5	10mm ²
Grounding Locations				
				

5kVA Lithium NA UPS Unit:

Model	Grounding Screw Size	Grounding Wire Gauge
U05N11L	Chassis M5	16mm ²
Grounding Locations		
		

6-10kVA VRLA UPS Units:

Model		Grounding Screw Size	Grounding Wire Gauge
VRLA	230V	U06S12V Terminal block: M4 Chassis: M5	10mm ²
		U10S12V Terminal block: M5 Chassis: M5	16mm ²
VRLA	208V	U06S11V Terminal block: M4 Chassis: M5	10mm ²
		U10S11V Terminal block: M5 Chassis: M5	16mm ²

Grounding Locations



6-10 kVA NA Lithium UPS Units, 5-10kVA EU Lithium UPS Units:

Model	Grounding Screw Size	Grounding Wire Gauge
U06N11L, U10N11L	Chassis M5 Terminal Block	16mm ²
U05N12L, U06N12L, U10N12L	Chassis M5 Terminal Block	16mm ²

Grounding Locations

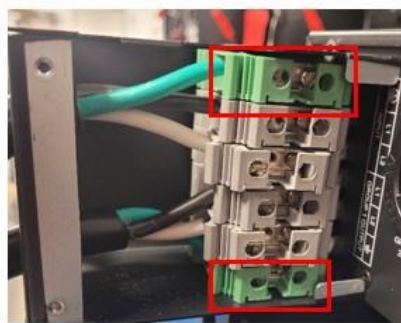

10-20kVA 3-Phase UPS Units:

Model		Grounding Screw Size	Grounding Wire Gauge
VRLA	400V	U10S32V	16 mm ²
		U15S32V	25 mm ²
		U20S32V	35 mm ²

Grounding Locations



1-3kVA VRLA EBP Units:

Model	Grounding Screw Size	Grounding Wire Gauge
UVP024	M4	10mm ²
UVP036		
UVP048		
UVP072		

Grounding Locations



1-3kVA Lithium EBP Unit:

Model	Grounding Screw Size	Grounding Wire Gauge
UVPL50H	M5	16mm ²

Grounding Locations

5-10kVA VRLA EBP Unit:

Model	Grounding Screw Size	Grounding Wire Gauge
UVP240	M5	16mm ²

Grounding Locations

5-10kVA Lithium EBP Unit:

Model	Grounding Screw Size	Grounding Wire Gauge
UVPL12H	M5	16mm ²
Grounding Locations		
		

10-20kVA VRLA EBP Unit:

Model	Grounding Screw Size	Grounding Wire Gauge
UVP480	M5	16 mm ²
Grounding Locations		
		

Recommended Grounding Setup Options Using Standard Cables:

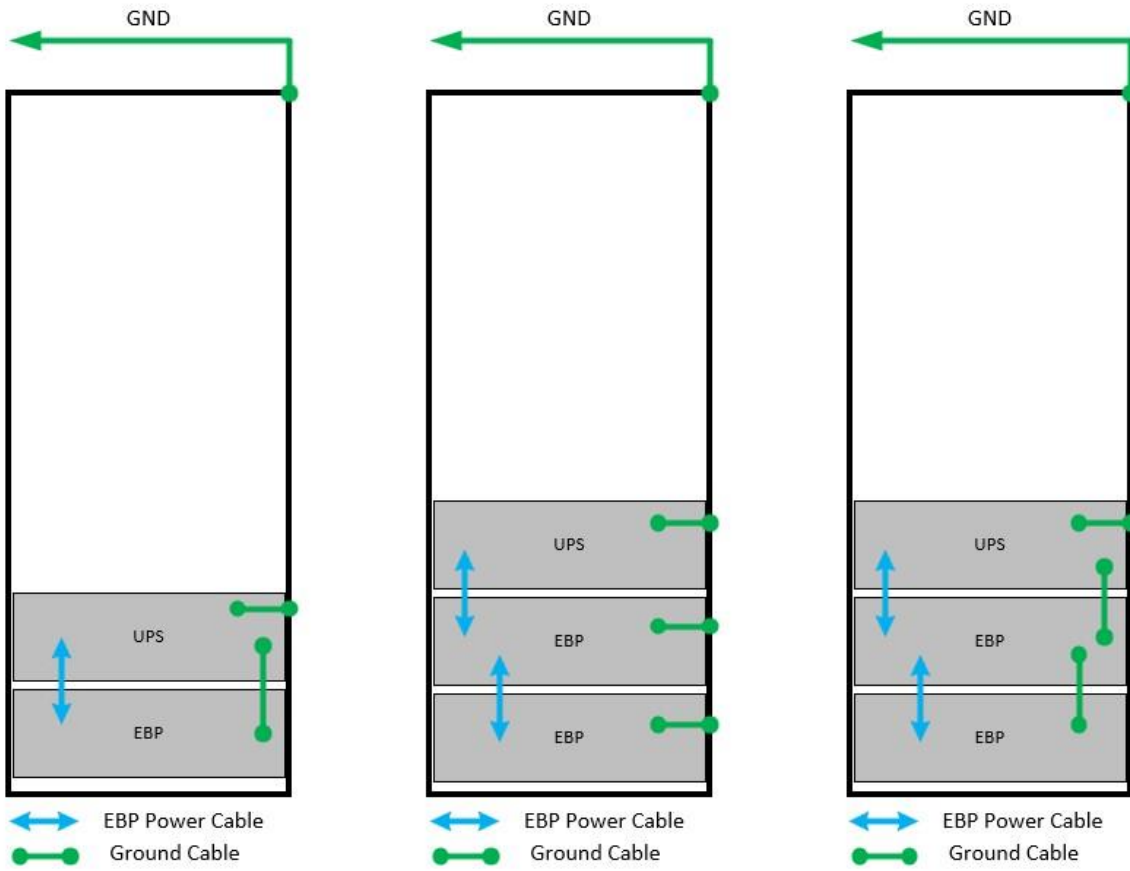

Recommended Grounding Setup Options for a Dual-Cabinet Setup Using Extended EBP Power Cables (*UVP1T3VCBL*, *UVP5T10VCBL*, *UVP10T20VCBL*):

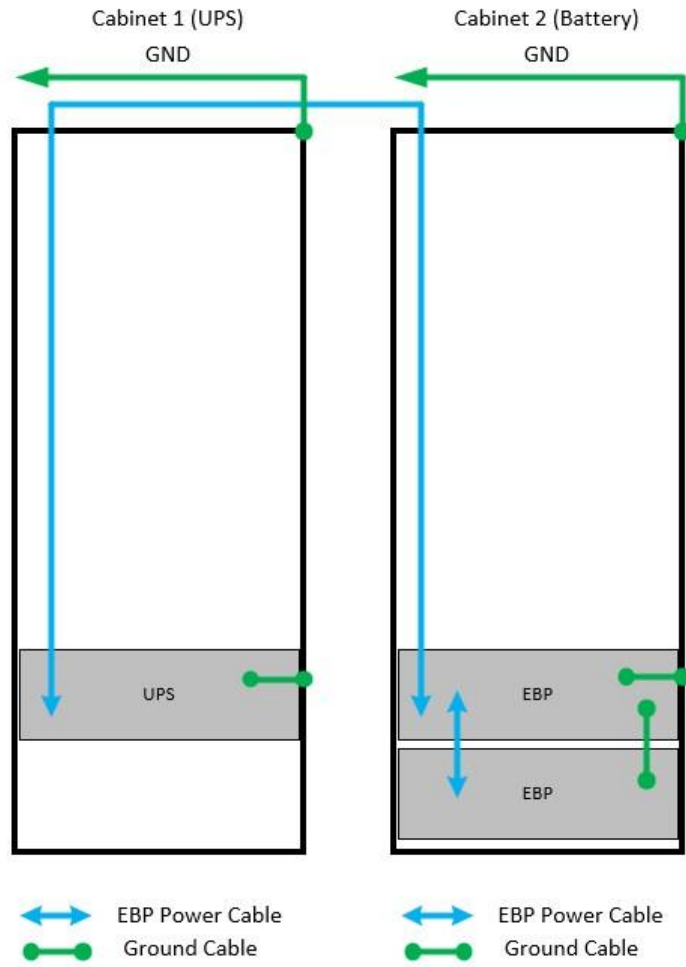

Additional Grounding Setup Options for the Panduit 5-10kVA Lithium UPS (U05N11L, U05N12L, U06N11L, U06N12L, U10N11L, U10N12L) Dual-Cabinet Setup Using Extended EBP Power cables (UVPL12HCBL):

