

THIS COPY IS PROVIDED ON A RESTRICTED BASIS AND IS NOT TO BE USED IN ANY WAY DETRIMENTAL TO THE INTERESTS OF PANDUIT CORP.

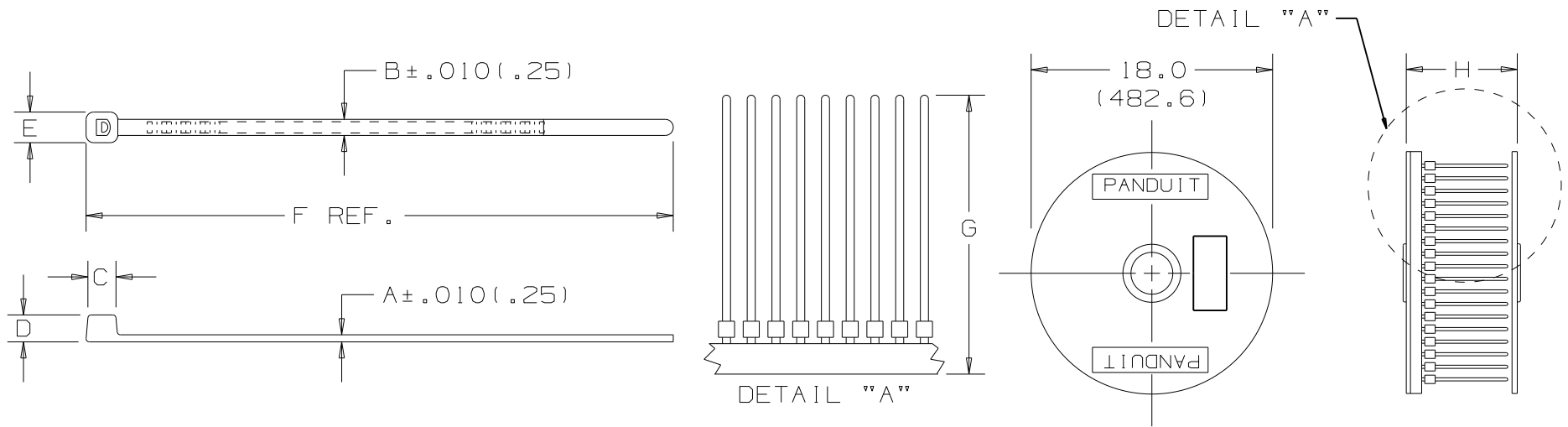

PANDUIT * PART NO.	BUNDLE DIA.		A IN. (mm)	B IN. (mm)	C IN. (mm)	D IN. (mm)	E IN. (mm)	F IN. (mm)	G IN. (mm)	H IN. (mm)	MINIMUM LOOP TENSILE lbs. (N)	CROSS SECTION	WEIGHT (W/O RIBBON) lbs. (g)/100 pcs
	MIN IN. (mm)	MAX IN. (mm)											
PLT1M-XMR	.02 (.5)	.82 (20.8)	.036 (.9)	.100 (2.5)	.175 (4.4)	.154 (3.9)	.185 (4.7)	4.0 (102)	4.5 (114)	5.3 (135)	18 (80)	MINIATURE	.06 (29)
PLT1.5M-XMR	.02 (.5)	1.31 (33.3)	.036 (.9)	.100 (2.5)	.175 (4.4)	.154 (3.9)	.185 (4.7)	5.6 (142)	6.0 (152)	6.8 (173)	18 (80)	MINIATURE	.08 (38)

NOTES:

- *1) SEE CURRENT PRICE SHEET FOR PART MATERIAL & COLOR SUFFIX DESIGNATIONS.
- 2) STANDARD PACKAGING: 5000 STRAPS PER REEL, 2 REELS PER CARTON.
- 3) PACKAGED FOR USE WITH FULLY AUTOMATIC CABLE TIE INSTALLATION SYSTEMS.
- 4) RECOGNIZED UNDER THE COMPONENT PROGRAM OF UNDERWRITERS LABORATORIES INC.

DIMENSIONS IN PARENTHESES ARE IN METRIC UNITS

PANDUIT CORP. TINLEY PARK, ILLINOIS

XMR PAN-TY CABLE TIES
PACKAGED FOR AUTOMATIC TOOLS

UNLESS OTHERWISE SPECIFIED,
DIMENSIONAL TOLERANCES ARE:
(.X) ±.10(2.5) (.XXX) ±.020(.51)
(.XX) ±.02(.5) ANGLES ±

UNLESS OTHERWISE SPECIFIED,
ALL DIMENSIONS ARE GIVEN
IN INCHES, THIRD ANGLE PROJECTION.

DRAWN BY
KJL

MAT'L:

SCALE
NONE

DATE
6/16/88

NYLON 6.6

DRAWING NO.

SS-18422

DWG
A
SIZE

REV	DATE	BY	CHK	DESCRIPTION	ECN	R	CUST	SUP
11	7/27/07	JABO		CHANGED PLT1M 'H' DIM TO 1 DECIMAL PLACE	18422	11		